



Welker[®] LSM-6AI Series Crude Oil Probe Sampler

Style LSM-6FAI



The Welker[®] LSM-6FAI automatic insertion crude oil sampler allows for a true isokinetic sample to be extracted from a properly conditioned pipeline, yielding the most accurate, reliable, and repeatable results in the industry. This style of sampler has the added benefit of being able to be inserted and retracted from the pipeline without having to depressurize the line.

Features

- Allows for automatic insertion and retraction from a fully pressurized pipeline
- No external sources needed for insertion or retraction. Uses pipeline product and pressure
- Equipped with Vanishing Chamber[™] or optional "B", "C", or "D" piston collection heads
- True isokinetic design at actual point of sample grab
- Samples a fixed volume at full line pressure
- Fully meets ISO 3171, API Chapter 8, Section 2 and ASTM D4177
- Works with constant pressure or atmospheric cylinders

TYPICAL INSTALLATION

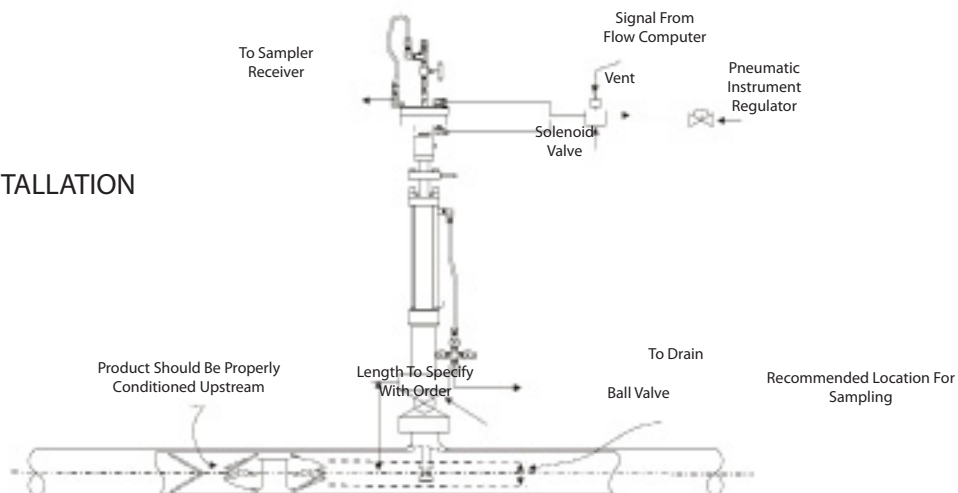

Welker® LSM-6FAI Series Crude Oil Probe Sampler

Specifications*

Application

The LSM-6FAI can be used with all products that are compatible with the materials of construction and seal material.

Pressure Rating

Atmospheric pressure up to 2,160 psi (149 Bar) or as determined by flange rating. Higher pressure ratings available.

Temperature Rating

From -20°F (-29°C) to +250°F (+121°C)

Viscosity

All fluid ranges

Sample Size

Vanishing Chamber™ standard sizes are 0.2cc, 0.5cc, 1cc and 1.5cc.

"B" Head piston style optional sizes are 0.5cc, 1cc, 2cc, 3cc and 4cc.

"D" Head piston style optional sizes are 3-7cc and 5-12cc.

"C" Head piston style optional sizes are 2-12cc and 10-30cc.

Sampler Actuation

Double-acting piston motor rated at 120 psi (8 bar) MAOP. Both actuating and release time should be 2 seconds minimum. Sampler actuation can be either time or flow proportional.

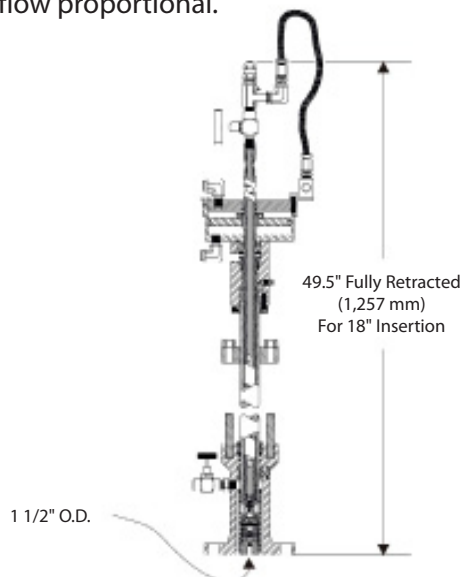

Materials

Lubricator body and piston motor are constructed of carbon steel, balance 316 stainless steel with Viton®, PTFE and Fluorotrel® seals.

Connections

All instrument connections are 1/4" FNPT.
Pipeline: 2" 150 ANSI RF standard.

Required Utilities

Instrument air 40 to 120 psi (4 to 8 Bar) dependent on line pressure. Air consumption 0.1 scf/grab @ 60 psi (2.9 ml/grab @ 4.2 Bar) as single acting; 0.25 scf/grab @ 60 psi (7.1ml/grab @ 4.2 Bar) as double acting.

Weight (With 18" (46 cm) travel)

75 lbs. (34 Kg.)

Non-standard designs available upon request

Options Available

- All 316 stainless steel construction
- Higher working pressures
- Other flange sizes and connections
- Other materials of construction
- Sand relief
- Other collection head sizes
- Certificates (material 3.1b, hydrostatic, functional, conformity, etc.)

Other Welker® Products

- In-line probe samplers
- Constant pressure cylinders
- Cylinder carrying cases
- Sampling take-off probes
- Probe regulators
- Crude oil receivers
- Complete system packages

Manufactured under U.S. Patents:

5,406,855 5,945,611 6,338,359

*Specifications subject to change without notice.
Drawings/Photos may be shown with optional equipment.



13839 West Bellfort Street Sugar Land, Texas 77498 | 281.491.2331 | sales@welker.com | welker.com

©2015 Welker, Inc. All Rights Reserved. Welker®, WelkerScope® and Welker Jet® are registered trademarks owned by Welker, Inc.