

Introduction

The electromagnetic flowmeter uses Faraday’s Law of electromagnetic induction to measure the process flow. The device consists of two units: a detector, through which the fluid to be measured flows and in which low-level signals proportional to flow rates are obtained; and a converter, which supplies excitation current to the detector, and amplifies the signals from the detector and then processes and converts the signals into the 4–20mA dc current signal or communication signal. The meter features a **Mount- Anywhere** magnetic field distribution technology, the meter is highly immune to upstream flow disturbances. Combined with a multi-functional converter LF620 (combined type) or LF622 (separate type) equipped with its patented **Noise-Sentry** original noise-suppression circuit and advanced algorithms. The LF410 has a very high tolerance to noise, giving the unit a very stable output even for slurry fluid measurement. IR (Infrared) switches enable parameter setting of the converter without removing the cover. Flow direction can be set in either way, and its unique 128 x 128 dot matrix LCD display allows the LCD to be rotated electronically to 90, 180 and 270 degrees without opening the cover.

- *1: HART protocol (Highway Addressable Remote Transducer) is a communication protocol for industrial sensors recommended by the HCF (HART Communication Foundation).
 - ** DevComm2000 Smart Device Communicator available for performing HART device configurations on PC or laptop is available through the supplier .
- *2: PROFIBUS is the communication protocol for factory and process automation that the PROFIBUS Organization recommends. Instead of analog control with a conventional analog signal (4-20mA), it is fieldbus which digitizes all signals. Flowmeters support PROFIBUS-PA.
- * Modbus is the communication protocol that Modicon Inc. developed. Physical layer is RS485.

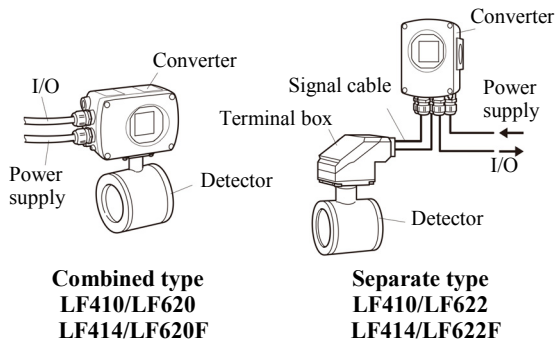

Figure1. Configuration



Figure2. LF410 Mount-Anywhere series Flowmeters



Certification number
Z01207

Specifications

Overall Specifications

Measurement range in terms of flow velocity:

- 1.0 ft/s to 32.8 ft/s (0.3 m/s to 10 m/s).
- 0.3 ft/s to 1.0 ft/s (0.1 m/s to 0.3 m/s)
- range is available optionally.

Accuracy: ±0.2 % of Rate*

- * This pulse output error result is established under standard operating conditions at Toshiba's flow calibration facility, Fuchu Japan. (NIST Traceable).
- * Individual meter measurement error may vary up to ±0.5% of Rate at 1.64ft/s (0.5m/s) or more and ±0.3% of rate ±0.039 inch/s (1mm/s) at 1.64 ft/s (0.5 m/s) or less.
- * Current output: plus ± 8µA (0.05% of span.)
- * Refer to individual calibration data for each individual meter's measurement error.

Fluid conductivity: 5µS/cm minimum

Fluid temperature:

- 14 to 356 °F (–10 to +180°C): Separate type for ceramic tube.
- 14 to 248°F (–10 to +120°C): Combine type for ceramic tube
- 14 to 248°F (–10 to +120°C) : Teflon PFA

Ambient temperature: –4 to 140 °F (–20 to +60 °C)

Structure: IP 67 and NEMA 4X Watertight

Power consumption:

Standard:10W(14VA)
at AC100V and Excitation current:0.2A

MAX:15W (22VA)

MAX:17W(24VA) with PROFIBUS

Conformance to European Community Directives:

PED 97/23/EC (Note 1)

Note: See Table 1 for detail.

Approved hazardous location certifications:

Model: LF414/LF620F and LF414/LF622F

cFMus Nonincendive for use in

hazardous (classified) locations:

Class I, II, III, Division 2, Groups A-G

Detector and converter combination:

LF410/LF620: Combined type for standard specification.

LF410/LF622: Separate type for standard specification.

LF414/LF620F: Combined type with Ex approval of Class I, Division 2 (cFMus).

LF414/LF622F: Separate type with Ex approval of Class I, Division 2 (cFMus).

Mount-Anywhere Technology:

With TOSHIBA's unique magnetic field distribution technology, the meter is highly immune to upstream flow disturbances.

A minimum of 1D (one diameter) length of upstream straight pipe from the flange is required to maintain the performance specification.

Note: The test results were obtained and demonstrated at TOSHIBA's flow calibration facility, Fuchu Japan.

■ Model LF410 and LF414 Detectors

Mounting style: Wafer type

Fluid pressure: -15 to 300psi, or -1.0 to 20 bar (-0.1 to 2.0MPa)

Note: Before shipping from the manufacturer, each detector unit is tested by following test condition.
Pressure... 600 psi, Time... 5 minutes

Connection flange standards:

ASME B16.5 class 150, ASME B16.5 class 300

EN1092-1 PN10, EN1092-1 PN16

JIS B 2220 10K, JIS B 2220 16K, JIS B 2220 20K

Principal materials:

Case —

1" to 4" (25 to 100mm): stainless steel

1/2", 6", and 8" (15, 150, 200mm): carbon steel

Linings —

1/2" to 4" (15 to 100mm): Ceramic tube (std.) & Teflon PFA (opt.)

6" to 8" (150 and 200mm): Teflon PFA

Electrodes —

Type-Super smooth, polished with self cleaning finish, and non stick shape

316 stainless steel (std.)

Hastelloy C equivalent (std.) (in case of Teflon PFA lining)

Note: Electrodes are electro-chemically polished after mechanically buffed.

Grounding rings — 316 stainless steel (std.)

Note: See Table 5 for optional materials and other related information.

Measuring tube material — 304 stainless steel in case of Teflon PFA lining.

Coating —

1" to 4" (25 to 100mm):

No coating (stainless steel body).

1/2", 6", and 8" (15, 150, 200mm):

Corrosion resistant phthalic acid resin coating with pearl-gray colored.

Heat shock resistance: for a ceramic tube detector

Heating: $\Delta T \leq 302^{\circ}\text{F}/0.5\text{sec}$ ($150^{\circ}\text{C}/0.5\text{sec}$)

Cooling: $\Delta T \leq 212^{\circ}\text{F}/0.5\text{sec}$ ($100^{\circ}\text{C}/0.5\text{sec}$)

Note: The above means that the ceramic tube detector withstands the shock of sudden heating (temperature difference 150°C or less per 0.5seconds) and sudden cooling (temperature difference 100°C or less per 0.5seconds).

Dimensions and weights: See Figures 3 to 8.

Cable connection port: for separate type detectors.

Cable glands —

LF410 (without cFMus approval):

Provided as standard, R(PT) 1/2 male threads.

LF414 (with cFMus approval):

Not provided, 3/4-14NPT male threads are required.

Applicable diameter —

0.433 to 0.512 inch (11 to 13mm)

■ Model LF620 and LF622 converters

Input signals

Analog signal — the voltage signal from detector, proportional to process flow rate (for LF622 separate type converter).

Digital input DI

Signal type: 20 to 30Vdc voltage signal
Input resistance: 2.7k Ω
Number of inputs: one point

DI function — One of the following functions can be assigned to the optional DI signal.

Range switching — Selects either the higher or lower range in the unidirectional or bidirectional 2-range setting.

Totalizer control — Starts and stops the built-in totalizer.

Fixed-value outputs — Outputs fixed-values for current and pulse outputs.

Zero adjustment — Executes zero adjustment (on-stream at zero flow rate).

Output signals

Current output:

4–20mAdc (load resistance 0 to 750 Ω)

Note: The current output cannot be used with the PROFIBUS-PA communication.
(Refer table 7 for details)

Digital outputs — Two points are optionally available as follows.

Digital output DO1:

Output type: Transistor open collector
Number of outputs: One point
Output capacity: 30Vdc, 200mA maximum

Note: DO1 cannot be used if Modbus communication connection is 3 lines.
(Refer table 7 for details)

Digital output DO2:

Output type:
Solid-state relay output (non polarity)
Number of outputs: One point
Output capacity: 150Vdc, 150mA maximum or 150Vac (peak to peak), 100mA maximum

Note: DO2 cannot be used with the Modbus communication. (Refer table 7 for details)

DO1 and DO2 functions — One of the following functions can be assigned to DO1 and/or DO2.

- **Pulse output (available only for DO1, DO2)**

Pulse rate: Max 10kHz (10,000pps) (DO1)
Max 100Hz (100pps) (DO2)

(Over 1kpps, auto-setting)

Pulse width: 0.3 to 500ms (but less than half of the period for 100% flow rate)

Note: The same and simultaneous pulse is not available between DO1 and DO2.)

- **Multi-range selection outputs (Note 1)**
- **High, High high, Low, and/or Low low alarm outputs (Note 2)**
- **Empty pipe alarm output**
- **Digital Output Active Status (DO1 and DO2) (Note 2)**
- **Preset count output**
- **Converter failure alarm output**

Note 1: Two outputs (DO1 and DO2) are needed for 4-range switching and forward/reverse 2-range switching.

Note 2: Normal Open (default set) or Normal Close is selected for alarm outputs when programming. When power failure occurs, unit will be fault to Normal Open.

Communications output:

- **HART (std.)** — Digital signal is superimposed on 4–20mAdc current signal as follows:

Conforms to HART protocol

Load resistance: 240 to 750 Ω

Load capacitance: 0.25 μ F maximum

Load inductance: 4mH maximum

- **PROFIBUS (opt.)**

Protocol: PROFIBUS-PA

Baud rate: 31.25kbps

Bus voltage: 9-30VDC

Consumption electric current of bus: less than 16mA

Manufacture Ident-No.: 093B_{HEX}

Standard Ident-No.: 9740_{HEX}

Slave address: 0-126 (Default address is 126)

Profile: Profile Ver.3.01 for Process Control Devices

Function blocks: AI(Flow) \times 1 , Totalizer \times 1

- **Modbus (opt.)**

Physical layer : RS485

Protocol : Modbus

Mode : RTU

Baudrate : 4800, 9600, 19200bps

Data length : 8bit

Parity bit : None, Odd, Even

Stop bit : 1bit, 2bit

Error check : CRC-16

Max. station number : 32(with Master device)

Max. cable length : 1.2km (Note)

Note: This length is specification of 3 line connection.

LCD display:

Full dot-matrix 128×128 dot LCD display
(back-light provided)
A parameter change will rotate the display.

Parameter settings — Parameters can be set as follows:

- **IR Switches:** Three key switches are provided to set configuration parameters.
- **Digital communication:** HART, PROFIBUS or Modbus is needed to set parameters.
- **Zero adjustment:** Zero point adjustment can be started by pressing the switch in the converter.
- **Damping:** 0.5 to 60 seconds (selectable in one second increments)

“Field re-verification” Mag-Prover – Toshiba’s Zero span calibration tool allows unit to be re-calibrated and verified using an internal software program (For more information contact Toshiba International Corp.)

Conditions when power fails:

Parameter setting values are stored in non-volatile memory and the values will be restored when the power returns to normal condition. The outputs and display will remain as follows when power fails.

- Current output: 0mA_{dc}
- Digital output: OFF
- LCD display: No display
- PROFIBUS: No communication

Power supply:

One of the following can be selected:

- 100 to 240Vac, 50/60Hz
(allowable voltage 80 to 264Vac)
110V_{dc}
(allowable voltage 90 to 130V_{dc})
- 24V_{dc} (allowable voltage 18 to 36V_{dc})

Surge protection:

Arresters are installed in the power supply and a current signal output circuit to help protect the meter from lightning and improve personnel safety.

Case: Aluminum alloy (equal to IP67)

Coating: Acrylic resin-baked coating, pearl-gray colored

Cable connection port:

Cable glands —

LF620 and LF622 without cFMus Approval:
Provided as standard, OD of cable ϕ 11~13mm
Material Nylon 66

G (PF) 1/2 male threads.

LF620F and LF622F with cFMus Approval:
Not provided, 1/2–14NPT male threads are required.

Applicable diameter —

0.433 to 0.512 inch (11 to 13mm)

Note: When PROFIBUS option is specified, cable gland size is ϕ 6~8mm for signal cable, ϕ 11~13mm for power cable

Vibration resistance:

No resonance to the following levels of vibration:

- 10 to 150Hz with acceleration of 9.8m/s²
- Vibration of 30Hz with 29.4 m/s² in 4h in each direction will not cause any defect to unit.

Note: Avoid using the flowmeter in an environment with constant vibration.

Dimensions and Weights:

See Figure 9 (for Separate type)

MTBF:

Converter: 220,000 hours (25 years) at 77 °F (25 °C)
based on strict military specification
MIL-HDBK-217F

Detector: 350,000 hours (40 years) at 77 °F (25 °C)
based on strict military specification
MIL-HDBK-217F

■ **PED matrix in each flange connection.**

The following sizes fall under the category for PED in each flange connection when the meter ships to EU. All of them had complied with it from a notified body.

Table 1. PED matrix in each flange connection

Flange standard	Meter size
EN 1092-1 PN 16	6 to 16 inch (150 to 400mm)
EN 1092-1 PN 10	10 to 16 inch (250 to 400mm)
ASME B 16.5 class 150 and JIS B 2220 10K	6 to 16 inch (150 to 400mm)

Installation

■ Dimensions

Unit: inch(mm)

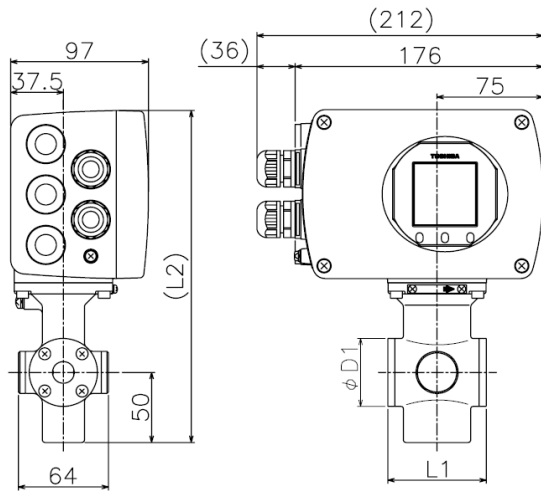

EN 1092-1 PN 16 and JIS B 2220 10K dimensions:

Meter size (mm)	L1 (mm)	L2 (mm)	D1 (mm)	Weight (kg)
15	70	237	49	approx. 4

Note: 1 inch = 25.4mm

ASME B 16.5 class 150 and class300 dimensions:

Meter size (inch)	L1 (inch)	L2 (inch)	D1 (inch)	Weight (lb)
1/2	2.76	9.33	1.93	approx. 9

**Figure 3. LF410/LF620 and LF414/LF620F flowmeters
Meter size 1/2"(15mm)**

Unit: inch(mm)

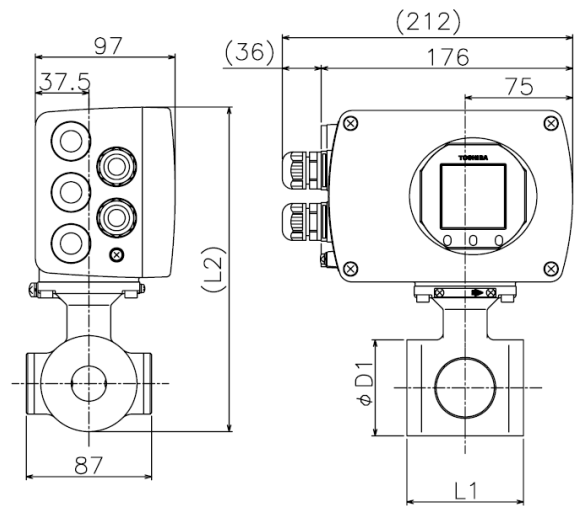

EN 1092-1 PN 16 and JIS B 2220 10K dimensions:

Meter size (mm)	L1 (mm)	L2 (mm)	D1 (mm)	Weight (kg)
25	80	226	66	approx. 4

Note: 1 inch = 25.4mm

ASME B 16.5 class 150 and class300 dimensions:

Meter size (inch)	L1 (inch)	L2 (inch)	D1 (inch)	Weight (lb)
1	3.15	8.90	2.60	approx. 9

Note: 1 inch = 25.4mm

**Figure 4. LF410/LF620 and LF414/LF620F flowmeters
Meter size 1"(25mm)**

The dimension of L1 changes when Pt-Ir or Ta material is chosen from the grounding ring.

Meter size	L1
1/2"(15mm)	3.03 inch(77mm)
1"(25mm)	3.74 inch(95mm)
1 1/2"(40mm)	4.53 inch(115mm)
2"(50mm)	4.96 inch(126mm)
3"(80mm)	4.96 inch(126mm)
4"(100mm)	5.35 inch(136mm)
6"(150mm)	9.53 inch(242mm)
8"(200mm)	12.28 inch(312mm)

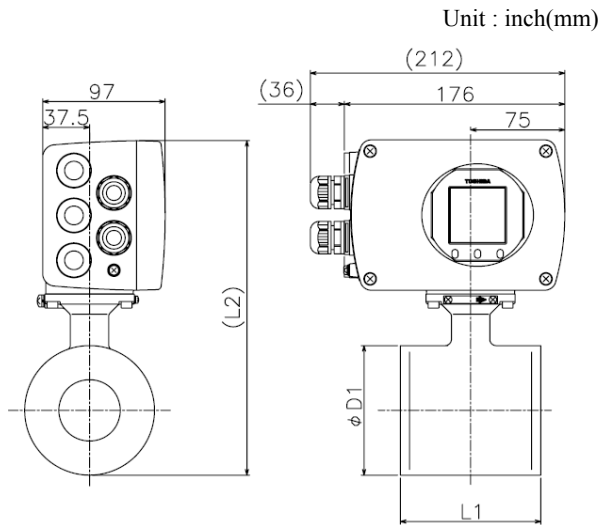

Note1: Eye bolts are provided at the top for flowmeters sized 8"(200mm).

Note2: 1 inch = 25.4mm

ASME B 16.5 class 150 and class300 dimensions

Meter size (mm)	L1 (mm)	L2 (mm)	D1 (mm)	Weight (kg)
40	100	249	85	approx. 5
50	110	265	102	approx. 6
80	110*	291	127	approx. 7
100	120*	323	159	approx. 9
150	230	392	216	approx. 21
200	300	443	267	approx. 35

ASME B 16.5 class 150 and class300 dimensions

Meter size (inch)	L1 (inch)	L2 (inch)	D1 (inch)	Weight (lbs)
1-1/2	3.94	9.80	3.35	approx. 11
2	4.33	10.43	4.02	approx. 14
3	4.33*	11.46	5.00	approx. 16
4	4.72*	12.72	6.26	approx. 20
6	9.06	15.43	8.50	approx. 47
8	11.81	17.44	10.51	approx. 77

*When Teflon PFA lining is selected, L1 in the table above becomes as follows:

- L1: 4.53 inch(115mm) for meter size 3"(80mm)
- L1: 4.96 inch(126mm) for meter size 4"(100mm)

The dimension of L1 changes when the material of grounding ring is chosen Pt-Ir or Ta

Meter size	L1
1/2"(15mm)	3.03 inch(77mm)
1"(25mm)	3.74 inch(95mm)
1 1/2"(40mm)	4.53 inch(115mm)
2"(50mm)	4.96 inch(126mm)
3"(80mm)	4.96 inch(126mm)
4"(100mm)	5.35 inch(136mm)
6"(150mm)	9.53 inch(242mm)
8"(200mm)	12.28 inch(312mm)

**Figure 5. LF410/LF620 and LF414/LF620F flowmeters
Meter sizes 1 1/2"(40mm) to 8"(200mm)**

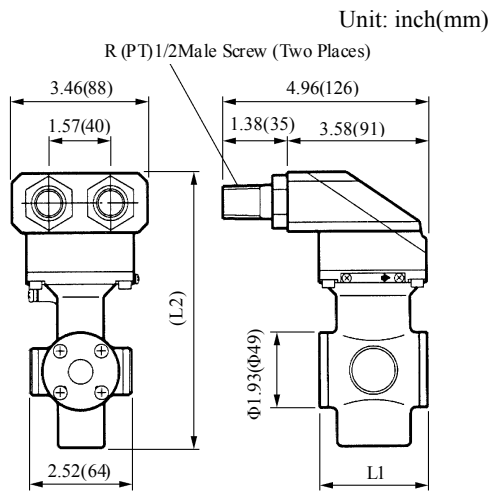

Note1: Cable glands are not provided for LF414 of FM and CSA approved type.
Refer to the part of Cable connection port at detector.

Note2: 1 inch = 25.4mm

ASME B 16.5 class 150 and class300 dimensions:

Meter size (inch)	L1 (inch)	L2 (inch)	D1 (inch)	Weight (lb)
1/2	2.76	7.05	1.93	approx. 7

EN 1092-1 PN16 and JIS B 2220 10K dimensions:

Meter size (mm)	L1 (mm)	L2 (mm)	D1 (mm)	Weight (kg)
15	70	179	49	approx. 3

The dimension of L1 changes when the material of grounding ring is chosen Pt-Ir or Ta

Meter size	L1
1/2"(15mm)	3.03 inch(77mm)
1"(25mm)	3.74 inch(95mm)
1 1/2"(40mm)	4.53 inch(115mm)
2"(50mm)	4.96 inch(126mm)
3"(80mm)	4.96 inch(126mm)
4"(100mm)	5.35 inch(136mm)
6"(150mm)	9.53 inch(242mm)
8"(200mm)	12.28 inch(312mm)

**Figure 6. Separate type detectors LF410/LF414
Meter sizes 1/2" (15mm)**

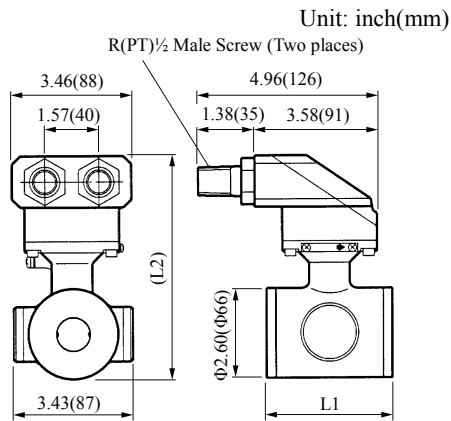

Note1: Cable glands are not provided for LF414 of FM and CSA approved type.

Refer to the part Cable connection port at detector.

Note2: 1 inch = 25.4mm

ASME B 16.5 class 150 and class300 dimensions:

Meter size (inch)	L1 (inch)	L2 (inch)	D1 (inch)	Weight (lb)
1	3.15	6.61	2.60	approx. 7

EN 1092-1 PN16 and JIS B 2220 10K dimensions:

Meter size (mm)	L1 (mm)	L2 (mm)	D1 (mm)	Weight (kg)
25	80	168	66	approx. 3

The dimension of L1 changes when the material of grounding is chosen Pt-Ir or Ta

Meter size	L1
1/2"(15mm)	3.03 inch(77mm)
1"(25mm)	3.74 inch(95mm)
1 1/2"(40mm)	4.53 inch(115mm)
2"(50mm)	4.96 inch(126mm)
3"(80mm)	4.96 inch(126mm)
4"(100mm)	5.35 inch(136mm)
6"(150mm)	9.53 inch(242mm)
8"(200mm)	12.28 inch(312mm)

**Figure 7. Separate type detectors LF410/LF414
Meter sizes 1" (25mm)**

ASME B 16.5 class 150 and class300 dimensions:

Meter size (inch)	L1 (inch)	L2 (inch)	D1 (inch)	Weight (lbs)
1-1/2	3.94	7.48	3.35	approx. 9
2	4.33	8.15	4.02	approx. 11
3	4.33*	9.13	5.00	approx. 13
4	4.72*	10.39	6.26	approx. 20
6	9.06	12.76	8.50	approx. 47
8	11.81	15.16	10.51	approx. 78

EN 1092-1 PN16 and JIS B 2220 10K dimensions:

Meter size (mm)	L1 (mm)	L2 (mm)	D1 (mm)	Weight (kg)
40	100	190	85	approx. 4
50	110	207	102	approx. 5
80	110*	232	127	approx. 6
100	120*	264	159	approx. 9
150	230	324	216	approx. 21
200	300	385	267	approx. 35

* When Teflon PFA lining is selected, L1 in the table above becomes as follows:

- L1: 4.53 inch(115mm) for meter size 3"(80mm)
- L1: 4.96 inch(126mm) for meter size 4"(100mm)

The dimension of L1 is changes when the material of grounding ring is chosen Pt-Ir or Ta

Meter size	L1
1/2"(15mm)	3.03 inch(77mm)
1"(25mm)	3.74 inch(95mm)
1 1/2"(40mm)	4.53 inch(115mm)
2"(50mm)	4.96 inch(126mm)
3"(80mm)	4.96 inch(126mm)
4"(100mm)	5.35 inch(136mm)
6"(150mm)	9.53 inch(242mm)
8"(200mm)	12.28 inch(312mm)

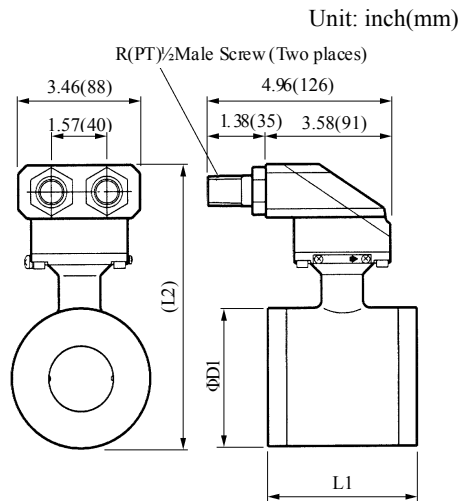

Note1: Cable glands are not provided for LF414 of FM and CSA approved type.
Refer to the part of Cable connection port at detector.

Note2: Eye bolts are provided at the top for flowmeters sized 8"(200mm).

Note3: 1 inch = 25.4mm

**Figure 8. Separate type detectors LF410/LF414
Meter sizes 1 1/2"(40mm) to 8"(200mm)**

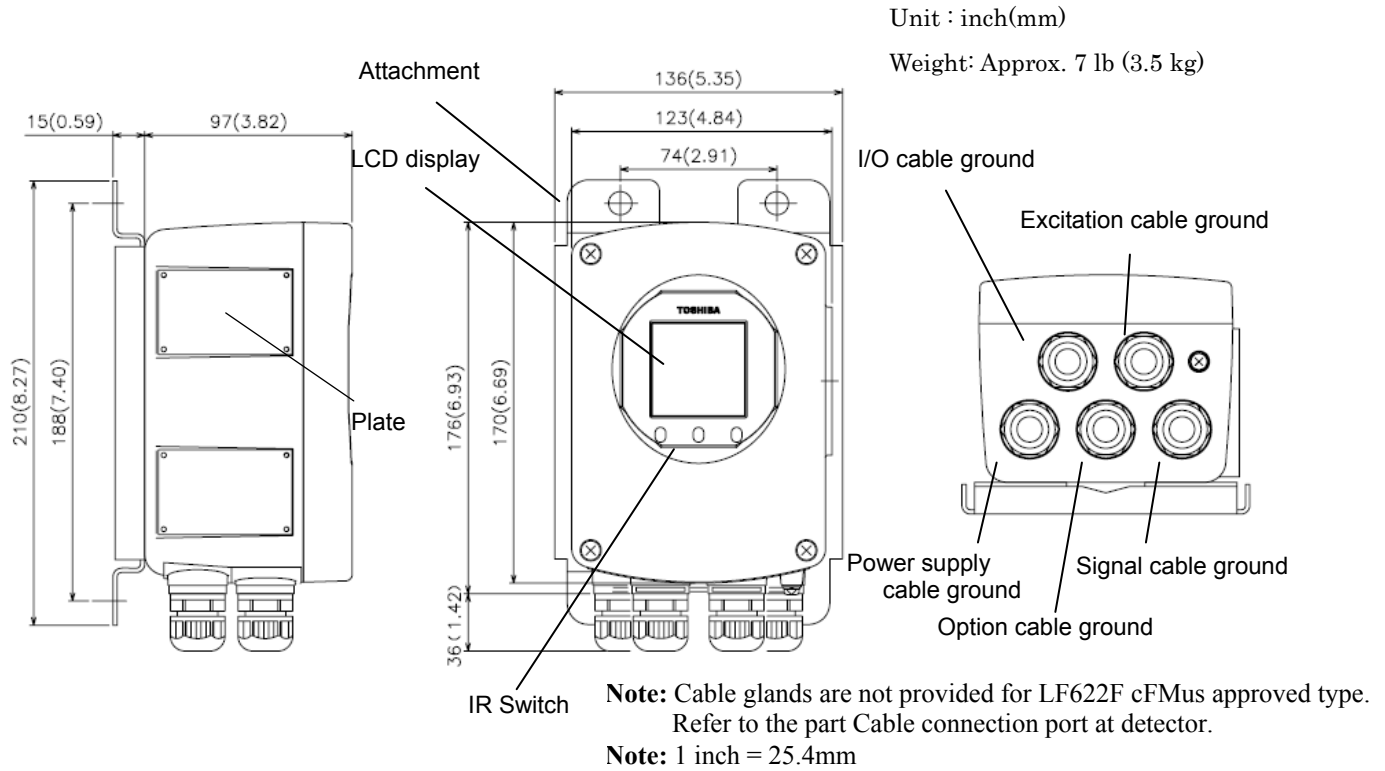
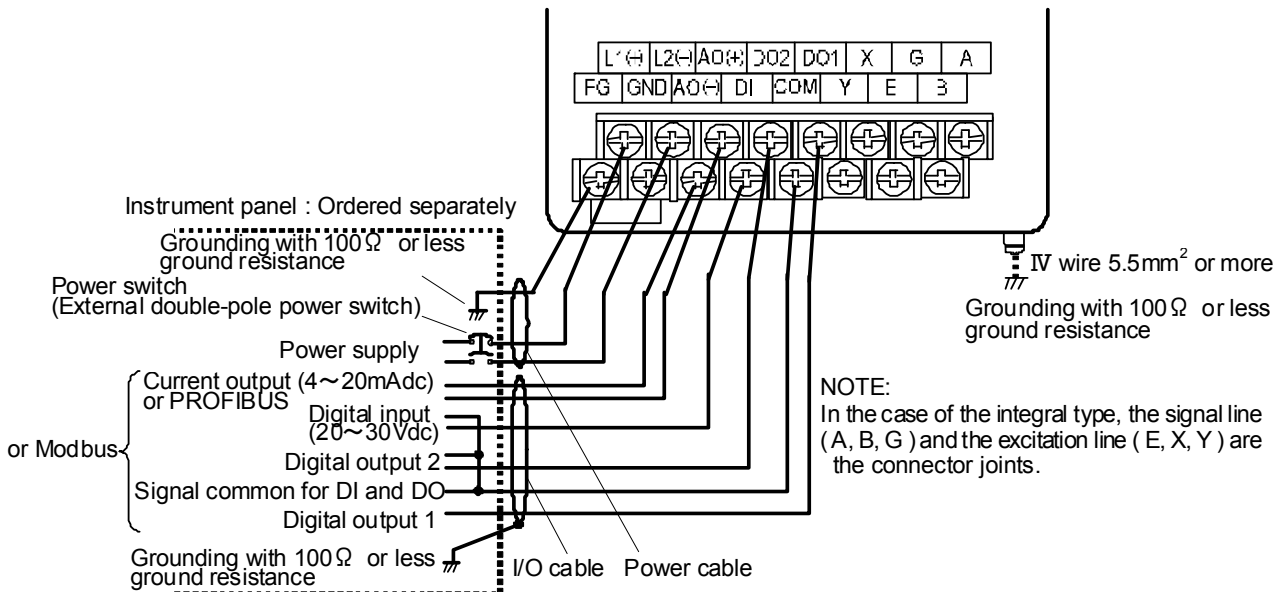

Figure 9. Separate type converter LF622 and LF622F

External Connections

- Combined type LF410/LF620 and LF414/LF620F flowmeters



*1 Locate an external double-pole power switch on the power line near the flowmeter within easy reach of operation. Use the appropriate switch rating as shown below:

Switch rating: 250Vac, 6A or more
In rush current: 15A or more

Figure 10. Combined type LF410/LF620 and LF414/LF620F flowmeters Wiring Diagram

• Separate type LF410/LF622 and LF414/LF622F flowmeters

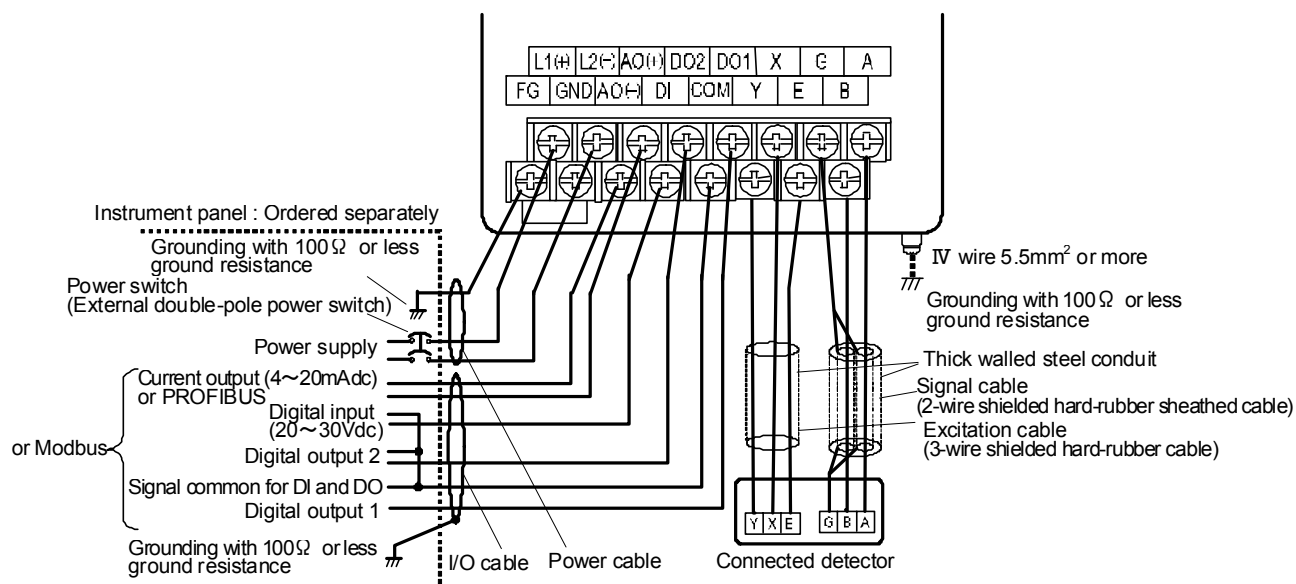

Figure 11. Separate type LF410/LF622 and LF414/LF622F flowmeters wiring Diagram

Table 2. LF620, LF620F, LF622 and LF622F Converters Signal Table

Symbol	Description	Cable
L1 (+)	Power supply	Power cable
L2 (-)		
GND	Ground (for arrester)	
FG	Frame ground	
DI	Digital Input (20~30Vdc)	I/O cable
DO1	Digital Output 1	
DO2	Digital Output 2	
COM	Signal Common for DI, DO1, DO2	
+	Current Output (4~20mAdc) or PROFIBUS	Shielded cable for PROFIBUS-PA
-		
X	Excitation Output	Excitation cable (for LF622, LF622F only)
Y		
E		
A	Signal Input	Signal cable (for LF622, LF622F only)
B		
G		
T+	Modbus(+)	Twisted-pair polyethylene insulated vinyl sheath cable (JKEV, AWG24(0.2mm ²))
T-	Modbus(-)	
TG	Modbus(GND)	

Note: Symbol of the terminal is changed as follows for Modbus.

DO2 → T+, DI → T-, COM → TG

■ Wiring Precautions

- (1) Explosion proof type flowmeters are not provided cable glands.
Refer to the part Cable connection port at detector and converter.
- (2) Connect the grounding wire (IV wire 5.5mm² or more) to a good earth ground (100Ω or less ground resistance). Make the wire as short as possible. Do not use a common ground shared with other equipment where earth current may flow. An independent earth ground is recommended.
- (3) The allowable cable lengths between the detector and converter for the separate type flowmeter depend on the electrical conductivity of the object fluid. See Figure 12.
- (4) DO1, DO2, and DI use the same common terminal (COM). This COM can not connect to other equipments which have their own ground terminal. (Power supply for connecting to DI or DO, etc...) Need to wire separately.

■ Wiring Precautions (PROFIBUS or Modbus)

- (1) For wiring path, avoid places near electrical equipment that may cause electromagnetic induction or electrostatic induction interference (such as a motor, transformer and wireless transmitter).
- (2) Use a PROFIBUS-PA cable for signal cable. In addition, make sure to use a shielded cable to improve noise resistance. Furthermore, installation of signal cable in metal conduit is recommended.
- (3) General PROFIBUS-PA cables are designed for indoor use where cables are not exposed to humidity, rain, etc. When you install cables, make sure to check the operating conditions such as the operating temperature range of the cable by contacting its manufacturer.
- (4) When you carry out cable end treatment of PROFIBUS-PA cable, use a dedicated cable stripper etc. so that the core wire of the cable will not be nicked or damaged. In addition, for cables, be careful of allowable maximum bend diameter etc. (Basically, do not install cables in a way cables are twisted or bent.)
- (5) Consider installing a PROFIBUS-PA arrester in the communication path of PROFIBUS-PA so that the electromagnetic flowmeter will not be affected by lightning etc.
- (6) The electromagnetic flowmeter is not equipped with terminating resistors. Use the terminating resistor unit for PROFIBUS-PA or junction box, if necessary.

- (7) Only one PROFIBUS-PA cable goes through a cable gland of the Electromagnetic Flowmeter. Please use the junction box at system configuration.
- (8) Install a terminator to flowmeter that connected to end of Modbus network.

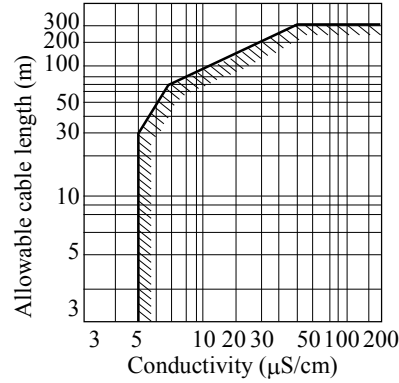

Figure 12. Electrical Conductivity and Cable Length

■ Meter Size

To select the meter size:

See Table 3 to 4 and find meter sizes within the velocity of 0.3 to 32.8 ft/s (0.1 to 10m/s) for a specified full-scale (measuring range high limit) flow. Select one that has its full-scale velocity between 3.0 and 10 ft/s (1 and 3m/s).

Note: Make sure the full-scale flow rate used for the final planning stage stays within 32.8 ft/s (10m/s) in terms of flow velocity.

Table 3. Flow rate and flow velocity (English unit)
Unit: gal/min

Size (inch)	Flow rate				
	0.328 ft/s	0.98 ft/s	3.0 ft/s	10 ft/s	32.8 ft/s
1/2	0.2801	0.8403	2.561	8.532	28.01
1	0.7781	2.334	7.115	23.72	77.81
1 1/2	1.992	5.975	18.21	60.71	199.2
2	3.112	9.337	28.46	94.86	311.2
3	7.967	23.90	72.85	242.8	796.7
4	12.45	37.35	113.8	379.4	1,245
6	28.01	84.03	256.1	853.8	2,801
8	49.80	149.4	455.3	1,518	4,980

Table 4. Flow rate and flow velocity (SI unit)
Unit: m³/h

Size (mm)	Flow rate				
	0.1 m/s	0.3 m/s	1.0 m/s	3.0 m/s	10 m/s
15	0.06362	0.1908	0.6361	1.908	6.361
25	0.1767	0.5301	1.767	5.301	17.67
40	0.4523	1.357	4.523	13.57	45.23
50	0.7067	2.120	7.067	21.20	70.67
80	1.809	5.428	18.09	54.28	180.9
100	2.827	8.482	28.27	84.82	282.7
150	6.361	19.08	63.61	190.8	636.1
200	11.31	33.93	113.1	229.3	1,131

■ About establishment environment

Do not store or install the flowmeter:

- Where there is direct sunlight.
- Where excessive vibration or mechanical shock occurs.
- Where high temperature or high humidity conditions exist.
- Where corrosive atmospheres exist.
- Places that can be submerged under water.
- Where there is a sloped floor. To put the flowmeter temporarily on the floor, place it carefully with something, such as a block, to support it so that the flowmeter will not topple over.

In areas like the following, there may be the case that infrared switches do not function correctly. (If these are unavoidable, use an appropriate cover.)

- (1) Where unit (operation panel) is exposed to direct sunlight, reflection of light onto window pane and diffused light reflection.
- (2) Where smoke and steam may occur.
- (3) Where exposed to direct snow, ice or mud.

Ordering Information

1. When ordering the LF410 series flowmeters, refer to Tables 5 and 6 (Type Specification Codes). An entry must be made for each of the columns in each of these tables.
2. Fluid characteristics:
 - (1) Type of fluid to be measured and its characteristics
 - (2) Fluid temperature
 - (3) Fluid pressure
 - (4) Electrical conductivity of the fluid
3. Measuring range
4. I/O function setting
5. Ordering scope:
 - Flow calibration data: (required or not)
6. Other items
 - Specifications other than standard items

Consult a Toshiba representative when choosing materials for lining, electrodes, and grounding rings.

**Toshiba International Corp. (Houston) stocks
Hazardous location certification type
flowmeters as standard inventory.**

Table 6. Specification Code for LF620/LF622 converters

Model				Specification Code										Contents	LF620 type	LF622 type	
1	2	3	4	5	6	7	8	9	10	11	12	13	14				
L	F	6	2														
															Electromagnetic flowmeter converter		
				0											Combined (Integral) type	●	—
				2											Separate (Remote) type	—	●
					A										Purpose		
					F										cFMus class I, Division 2 non-approved	○	○
															cFMus class I, Division 2 approved	●	●
						A									Shape		
															Standard type with case	●	●
							A								Converter mounting fitting		
							C								None	●	○
							E								Panel, Accessory for wall mounting (BNP material: SUS304)	—	●
															Accessory for pipe installation (BNP material: SUS304)	—	○
								2							Digital input/output		
															Digital output points 2 (DO1+DO2) +Digital input point 1 (DI)	●	●
									1						Current output and Communication function(Note1)		
									2						Current output + HART communication	●	●
									3						PROFIBUS communication	○	○
															Current output + Modbus (RS485) communication	○	○
										1					Power supply(Note 2)		
										2					100Vac-240Vac 50/60Hz , 110Vdc	●	●
										3					24Vdc	○	○
															110Vdc	○	○
											E				Instruction manual		
															English	●	●

Code explanation: ●: Standard ○: Option —: Not available

Note 1: When PROFIBUS communication is provided, current output(4-20mA) and HART communication cannot be used.
When Modbus communication is provided, digital output points 1(DO1) and digital output points(DO2),
digital input point 1(DI), HART communication cannot be used.
Refer Table 7 for more details.

Note2: Select 110Vdc for test report inspected under the condition of 110Vdc.

Table7. Communication functions and output selection table

Selection of Function		Availability of outputs			
Code (10 th digit)	Selected Communication	4-20mAde	DO1	DO2	DI
1	HART	✓	✓	✓	✓
2	PROFIBUS	X	✓	✓	✓
3	Modbus	✓	✓ (Note)	X	X

Code explanation: ✓:Available X:Not Available

Note: When digital output 1 function and Modbus communication function are used at one time, TG (signal ground) of the Modbus communication function cannot be connected (2 line connection).

ISO9001 and ISO14001 are certified.



Misuse of this product can result in damages to property or human injury.
Read related manuals carefully before using this product.

Specifications are subject to change without notice.

Printed in Japan 2012-7 (TDOC)

© TOSHIBA Corporation 2015

All Rights Reserved.

<http://www.toshiba.com/ind/>