

# Pro-V™ Multivariable Flowmeter

## Model M24 In-line Vortex



VorTek Instruments Pro-V™ M24 Multivariable Vortex Flowmeter offers accurate and reliable flow metering in a multivariable design. The multivariable design incorporates a high-accuracy velocity sensor, a precision platinum RTD temperature sensor, and a solid-state pressure transducer. The M24 can deliver volumetric flow, mass flow, temperature, pressure, density, and energy (BTU) measurements

from a single installed device. This drastically reduces complexity, equipment costs, and installation costs in comparison to installing multiple stand-alone instruments to arrive at the same process measurements.

The M24 includes a reduced bore option. The meter's process connections match the line size but using integrated reducing flanges, the meter body is reduced in diameter. This increases the fluid velocity through the meter. Increasing the velocity in this fashion extends the meter's measuring range to capture lower flow rates that might otherwise be missed in a full line size meter.

The M24 flowmeter offers an industry-leading variety of communication and power options. In addition to providing traditional communication methods such as analog output signals, the flowmeter also offers the latest and most advanced serial communication options such as BACnet®/IP and Modbus® TCP/IP. The M24 is the only vortex flowmeter on the market to provide Power over Ethernet (PoE) capabilities. Power over Ethernet functionality delivers power and data through a single ethernet cable. Both simplifying installation and reducing installation costs.

### Pro-V™ Advantage:

- Volumetric or mass flow monitoring of most liquids, gases, and steam
- Multivariable design delivers volumetric flow, mass flow, temperature, pressure, density, and energy (BTU) measurements from a single installed device
- Mass flow equations—real gas, ideal gas, AGA 8, API 2540
- Compensated mass flow reading of liquids, gases, and steam
- Energy (BTU) Monitoring—ability to compute and output energy use
- Reduced bore option to capture low flow conditions
- Reliable—no moving parts, no fluid to sensor contact
- High accuracy with rangeability up to 100:1
- Temperatures up to 750°F
- Pressures up to 1500 psig
- Remote electronics option available for use in harsh environments or locations with limited access
- Two-wire loop—powered design saves on energy costs
- HART protocol communications—Standard
- Advanced serial communication options: BACnet®/IP, Modbus® TCP/IP, BACnet® MS/TP, and Modbus® RTU
- Power over Ethernet (PoE) functionality delivers power and data through a single Ethernet cable
- FM, FMC, ATEX, IECEx Approved



**VorTek**  
INSTRUMENTS

VorTek Instruments, LLC  
8475 West I-25 Frontage Rd., Suite 300  
Longmont, CO 80504 USA  
Tel: 303/682-9999 Fax: 303/682-4368  
info@vortekinst.com

## Pro-V™ Principle of Operation

Vortex flowmeters measure flows of liquid, gas and steam by detecting the frequency at which vortices are alternately shed from a bluff body. According to proven laws of physics, the frequency at which the vortices are alternately shed is directly proportional to the flow velocity.

As flow passes a bluff body in the flow stream, the vortices create low and high pressure zones behind the bluff body, or shedder bar. The Pro-V™ M24 uses a piezoelectric crystal sensor to detect the pressure exerted by the vortices on the velocity sensor. The piezoelectric converts these “pulses” into electrical signals. The meter uses an all welded sensor design to create a robust sensor and to minimize potential leakages.

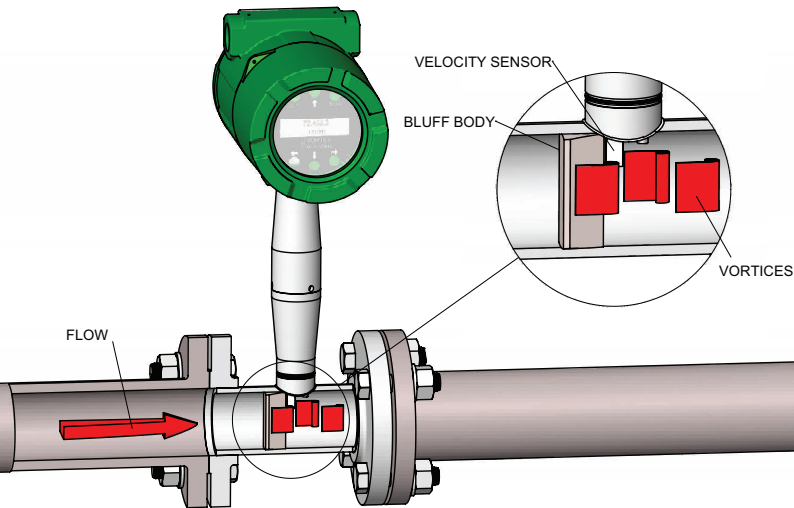

### Pro-V™ Model M24-VTP

The Model M24-VTP offers you flow computer functionality in a compact field device. This multivariable instrument incorporates temperature and pressure sensors to provide an instantaneous reading of the compensated mass flow rate of gases, liquids and steam. In addition to outputs for totalized mass and alarm settings, the field-configurable electronics deliver up to three analog 4-20 mA outputs of five process measurements, including volumetric flow rate, mass flow rate, pressure, temperature and density.

### Pro-V™ Model M24-VT

The Model M24-VT integrates a precision 1000 Ohm platinum RTD temperature sensor that can be used to calculate and output a compensated mass reading. This device is typically used to measure flow rates of saturated steam.

### Pro-V™ Model M24-V

The Model M24-V delivers a direct reading of volumetric flow rate—generally the most cost-effective solution for liquid flow monitoring—in applications ranging from general water flows to hydrocarbon fuel flow measurement.

### Pro-V™ Model M24-EM

The Model M24 Energy Monitoring option permits real-time calculation of energy consumption for a facility or process. The meter can be programmed to measure steam, hot water or chilled water. The Model M24-VTP flowmeter monitors one side of the process, either sent or returned, and uses the input from a second separate temperature sensor on the opposite leg of the process to calculate the change in energy. Selectable energy units include Btu, joules, calories, Watt-hours, Megawatt-hours and Horsepower-hours. The local or remote electronics indicate two temperatures, delta T, mass total and energy total.

### Pro-V™ Model M24-VTEP, VETEP

Similar to M24-VTP but with the option for an external input (T or P) via RTD or 4-20mA or one of each.

## Performance Specifications

### Accuracy

Mass flow rate accuracy for gas and steam based on 50-100% of pressure range.

Model M24 Multiparameter Inline Vortex Meter		
Process Variables	Liquids	Gas & Steam
Volumetric Flow Rate	± .7% of Rate	± 1% of Rate
Mass Flow Rate	± 1% of Rate	± 1.5% of Rate
Temperature	± 2°F (± 1°C)	± 2°F (± 1°C)
Pressure	± .3% of Full Scale	± .3% of Full Scale
Density	± .3% of Reading	± .5% of Reading

### Repeatability

Mass Flow Rate . . . . . ± .2% of rate  
 Volumetric Flow Rate . . . . . ± .1% of rate  
 Temperature . . . . . ± .2°F (± .1°C)  
 Pressure . . . . . ± .05% of full scale  
 Density . . . . . ± .1% of reading

### Stability Over 12 Months

Mass Flow Rate . . . . . ± .2% of rate  
 Volumetric Flow Rate . . . . . ± negligible  
 Temperature . . . . . ± .9°F (± .5°C)  
 Pressure . . . . . ± .1% of full scale  
 Density . . . . . ± .1% of reading

### Response Time

Adjustable from 1 to 100 seconds

## Operating Specifications

Any gas, liquid or steam compatible with 316L stainless steel, C276 hastelloy or A105 carbon steel. Not recommended for multi-phase fluids.

### Process and Ambient Temperature

Process Standard Temperature (code ST): -330 to 500°F (-200 to 260°C)  
 Process High Temperature (code HT): to 750°F (400°C)  
 Ambient Operating: -40 to 140°F (-40 to 60°C)  
 Ambient Storage: -40 to 185°F (-40 to 85°C)

Pressure Transducer Ratings			
Full Scale Operating Pressure		Max. Over-Range Pressure	
psia	bara	psia	bara
30	2	60	4
100	7	200	14
300	20	600	40
500	35	1000	70
1500	100	2750	175



## Power Requirements

DCL option: 12-36 VDC, 25mA, 1W max, loop powered (single output)  
 DCH option: 12-36 VDC, 300mA, 9W max, (multiple outputs)  
 DCHPOE option: 12-28 VDC or Power over Ethernet, 5W maximum (multiple outputs)  
 AC option: 100-240 VAC, 50/60Hz line power, 5W (multiple outputs)

## Display

Alphanumeric 2 line x 16 character LCD digital display  
 Six pushbuttons for full field configuration  
 Pushbuttons can be operated with magnetic wand without removal of enclosure covers  
 Display can be mounted in 90° intervals for better viewing

## Output Signals

Analog: 4-20 mA  
 Alarm: Solid state relay, 40 VDC  
 Totalizer Pulse: 50 millisecond pulse, 40 VDC  
 Volumetric or Loop Powered Mass: One analog, one totalizer pulse, HART  
 Multivariable option: Up to three analog signals, three alarms, one totalizer pulse, HART  
 Multivariable option: Modbus or BACnet process monitoring

## Physical Specifications

## Wetted Materials

Standard 316L Stainless Steel, plus

- Optional Carbon Steel or Hastelloy C
- DuPont Teflon® based thread sealant on models with pressure transducer

## Approvals

FM, FMC CLASS I, DIV. 1, GROUPS B,C,D  
 CLASS II/III, DIV. 1, GROUPS E,F,G  
 Type 4X and IP66, T6, Ta = -40 to 60°C

ATEX II 2 G Ex d IIB + H2 T6  
 II 2 D EX tD A21 IP66 T85°C, Ta = -40 to 60°C

IECEx Ex d IIB + H2 T6  
 Ex tD A21 IP66 T85°C, Ta = -40 to 60°C

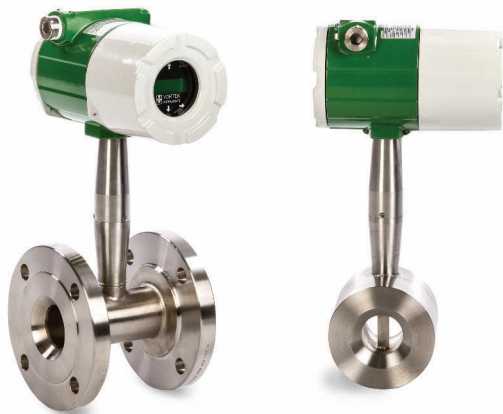

## Sizing Considerations

### Piping Conditions

Condition	Pipe Diameters, D	
	Upstream	Downstream
One 90° elbow before meter	10D	5D
Two 90° elbows before meter	15D	5D
Two 90° elbows before meter, out of plane	30D	10D
Reduction before meter	10D	5D
Expansion before meter	20D	5D
Partially open valve	30D	10D

## Velocity Range

Maximum velocity, liquid: 30 feet/sec (9 meters/second)  
 Minimum velocity, liquid: 1 foot/sec (.3 meters/second)  
 Maximum velocity, gas or steam: See Table Below  
 Minimum velocity, gas or steam feet/sec (meters/second):

$$\frac{5}{\sqrt{\text{density (Lb/ft}^3\text{)}}} \quad \frac{6.1}{\sqrt{\text{density (kg/m}^3\text{)}}}$$

## Pressure Drop Equations

$\Delta P = 0.00024pV^2$  English Units ( $\Delta P$  in psi, p in lb/ft<sup>3</sup>, V in ft/sec)  
 $\Delta P = 0.000011pV^2$  Metric Units ( $\Delta P$  in bar, p in kg/m<sup>3</sup>, V in m/sec)

Consult the VorTek Instruments Sizing Program at <https://vortek.sizingapp.com> for easy calculation of flow range.

### Water Minimum and Maximum Flow Rates

Rate	Nominal Pipe Size (in)										
	0.5	0.75	1	1.5	2	3	4	6	8	10	12
GPM min	0.9	1.4	2.2	5.5	9.2	21	36	81	142	224	317
GPM max	22	40	67	166	276	618	1076	2437	4270	6715	9501
	Nominal Pipe Size (mm)										
	15	20	25	40	50	80	100	150	200	250	300
M <sup>3</sup> /hr min	0.2	0.3	0.5	1.3	2.1	4.7	8.1	18	32	51	72
M <sup>3</sup> /hr Max	5	9	15	38	63	140	244	554	970	1525	2158

### Gas or Steam Max Velocity

Rate	Nominal Pipe Size (in)										
	0.5	0.75	1	1.5	2	3	4	6	8	10	12
FT/SEC Max	175	250	250	300	300	300	300	300	300	300	300
	Nominal Pipe Size (mm)										
	15	20	25	40	50	80	100	150	200	250	300
M/SEC Max	53	76	76	90	90	90	90	90	90	90	90

## Turndown

Turndown is application dependent.  
 Consult the VorTek Instruments Sizing Program at <https://vortek.sizingapp.com>  
 Turndown can exceed 100:1

## Dimensional Outline: Pro-V™ Inline Flanged Models

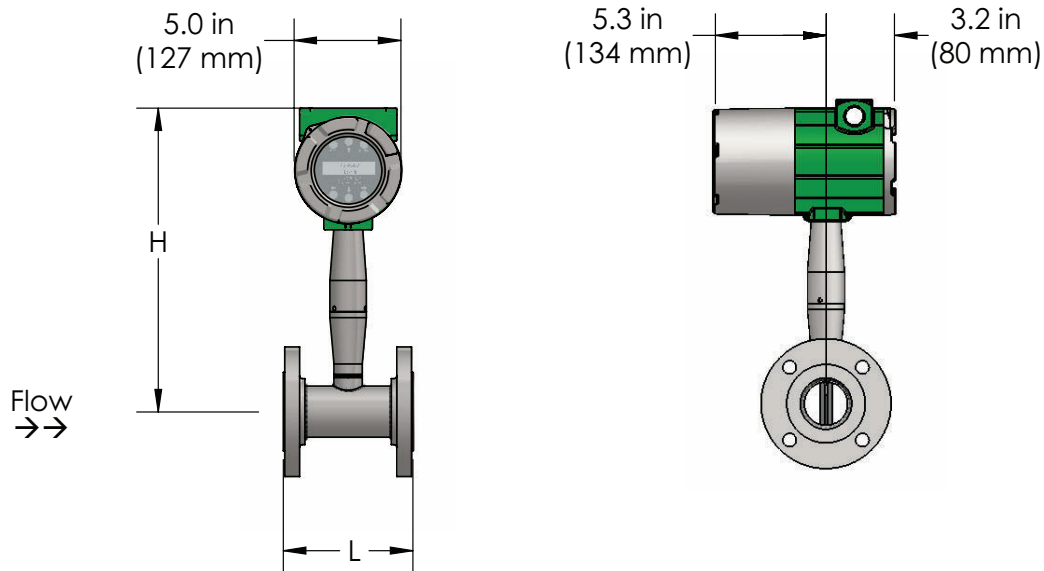

Flow Meter Nominal Size				Weight			
	L	L (ANSI 900)	H	ANSI 150 (PN 16)	ANSI 300 (PN 40)	ANSI 600 (PN 63)	ANSI 900 (PN 160)
1/2 inch (15mm)	7.9 in (200 mm)	7.9 in (201 mm)	13.5 in (343 mm)	12 Lb (5.5 kg)	12.5 Lb (5.7 kg)	13.4 Lb (6.1 kg)	17.6 lb (8 kg)
3/4 inch (20 mm)	7.9 in (200 mm)	9.7 in (247 mm)	13.5 in (343 mm)	13 Lb (5.9 kg)	14.6 Lb (6.6 kg)	15.6 Lb (7.1 kg)	21.0 lb (9.5 kg)
1 inch (25 mm)	7.9 in (200 mm)	10.8 in (274 mm)	13.5 in (343 mm)	13.5 Lb (6.1 kg)	16.3 Lb (7.4 kg)	16.4 Lb (7.5 kg)	26.3 lb (11.9 kg)
1.5 inch (40 mm)	7.9 in (200 mm)	12.0 in (305 mm)	13.8 in (351 mm)	16.3 Lb (7.4 kg)	23.3 Lb (10.6 kg)	24.6 Lb (11.2 kg)	37.2 lb (16.9 kg)
2 inch (50 mm)	7.9 in (200 mm)	14.1 in (357 mm)	14.0 in (356 mm)	21.2 Lb (9.6 kg)	26.8 Lb (12.2 kg)	33.2 Lb (15.1 kg)	60.5 lb (27.4 kg)
3 inch (80 mm)	7.9 in (200 mm)	14.8 in (375 mm)	14.6 in (371 mm)	33 Lb (15.0 kg)	41.0 Lb (18.6 kg)	56.1 Lb (25.5 kg)	76.5 lb (34.7 kg)
4 inch (100 mm)	9.84 in (250 mm)	16.9 in (429 mm)	15.1 in (384 mm)	45.8 Lb (20.8 kg)	66.8 Lb (30.3 kg)	96.0 Lb (43.6 kg)	121.2 lb (55 kg)
6 inch (150 mm)	11.81 in (300 mm)	19.5 in (495 mm)	16.2 in (411 mm)	68.3 Lb (31.0 kg)	106.3 Lb (48.2 kg)	194.3 Lb (88.2 kg)	254.4 lb (115.4 kg)
8 inch (200 mm)	11.81 in (300 mm)	22.8 in (579 mm)	17.2 in (437 mm)	112.4 Lb (51.0 kg)	168.4 Lb (76.5 kg)	299.0 Lb (136 kg)	433.0 lb (196.4 kg)
10 inch (250 mm)	15 in (381 mm)	29.0 in (737 mm)	18.2 in (462 mm)	188.3 Lb (85.5 kg)	262.3 Lb (119.1 kg)	462.3 Lb (209.9 kg)	665.9 lb (302.0 kg)
12 inch (300 mm)	17.7 in (450 mm)	30.3 in (770 mm)	19.2 in (488 mm)	298.6 Lb (135.6 kg)	402.6 Lb (182.8 kg)	606.6 Lb (275.4 kg)	926.6 lb (420.3 kg)

Add 11 lb (5 KG) for remote electronics

## Dimensional Outline: Pro-V™ Inline Reduced Bore Flanged Models

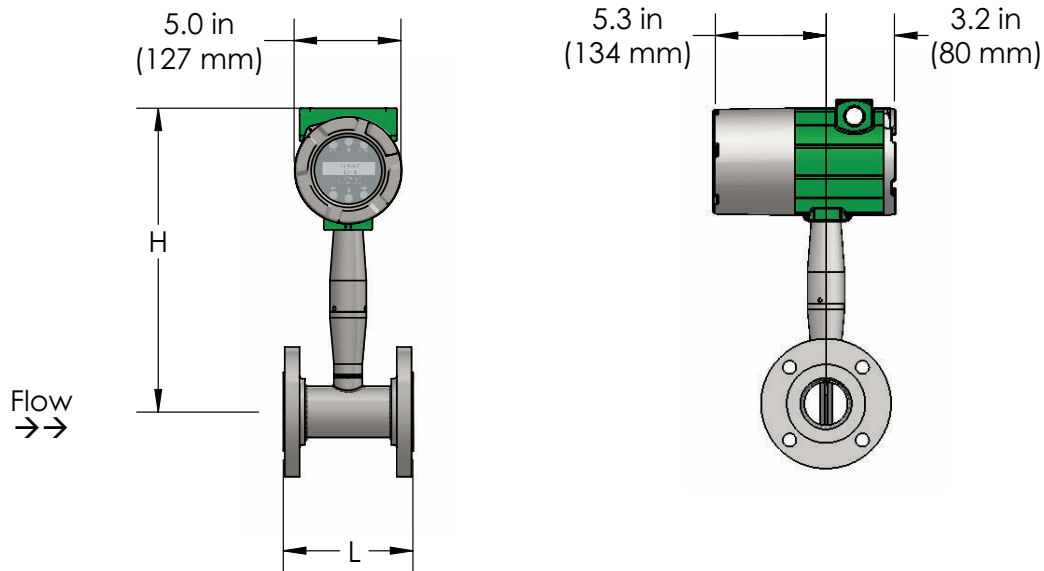

Flow Meter Nominal Size				Weight			
	L	L (ANSI 900)	H	ANSI 150 (PN 16)	ANSI 300 (PN 40)	ANSI 600 (PN 63)	ANSI 900 (PN 160)
3/4 inch (20 mm) X 1/2 inch (15mm)	7.9 in (200 mm)	8.4 in (213 mm)	13.5 in (343 mm)	13 Lb (5.9 kg)	14.6 Lb (6.6 kg)	15.6 Lb (7.1 kg)	20.6 lb (9.3 kg)
1 inch (25 mm) X 1/2 inch (15 mm)	7.9 in (200 mm)	8.4 in (213 mm)	13.5 in (343 mm)	13 Lb (5.9 kg)	16.3 Lb (7.4 kg)	16.4 Lb (7.5 kg)	22.7 lb (10.3 kg)
1.5 inch (40 mm) X 1 inch (25 mm)	7.9 in (200 mm)	11.1 in (282 mm)	13.8 in (351 mm)	13.4 Lb (6.1 kg)	23.3 Lb (10.6 kg)	24.6 Lb (11.2 kg)	36.3 lb (16.5 kg)
2 inch (50 mm) X 1-1/2 inch (40 mm)	7.9 in (200 mm)	12.5 in (318 mm)	14.0 in (356 mm)	16.3 Lb (7.4 kg)	26.8 Lb (12.2 kg)	33.2 Lb (15.1 kg)	58.1 lb (26.4 kg)
3 inch (80 mm) X 2 inch (50 mm)	7.9 in (200 mm)	14.1 in (357 mm)	14.6 in (371 mm)	21.2 Lb (9.6 kg)	41.0 Lb (18.6 kg)	56.1 Lb (25.5 kg)	73.7 lb (33.4 kg)
4 inch (100 mm) X 3 inch (80 mm)	9.84 in (250 mm)	15.3 in (389 mm)	15.1 in (384 mm)	33 Lb (15.0 kg)	66.8 Lb (30.3 kg)	96.0 Lb (43.6 kg)	116.1 lb (52.7 kg)
6 inch (150 mm) X 4 inch (100 mm)	11.81 in (300 mm)	17.8 in (452 mm)	16.2 in (411 mm)	45.8 Lb (20.8 kg)	106.3 Lb (48.2 kg)	194.3 Lb (136 kg)	220.5 lb (100.0 kg)
8 inch (200 mm) X 6 inch (150 mm)	11.81 in (300 mm)	20.1 in (511 mm)	17.2 in (437 mm)	68.3 Lb (31.0 kg)	168.4 Lb (76.5 kg)	299.0 Lb (88.2 kg)	365.7 lb (165.9 kg)
10 inch (250 mm) X 8 inch (200 mm)	15.0 in (381 mm)	23.3 in (592 mm)	18.2 in (462 mm)	188.3 Lb (85.5 kg)	262.3 Lb (119.1 kg)	462.3 Lb (209.9 kg)	562.8 lb (255.3 kg)
12 inch (300 mm) X 10 inch (250 mm)	17.7 in (450 mm)	29.7 in (754 mm)	19.2 in (488 mm)	298.6 Lb (135.6 kg)	402.6 Lb (182.8 kg)	606.6 Lb (275.4 kg)	792.3 lb (359.4 kg)

Add 11 lb (5 KG) for remote electronics

## Dimensional Outline: Pro-V™ Inline Wafer Models

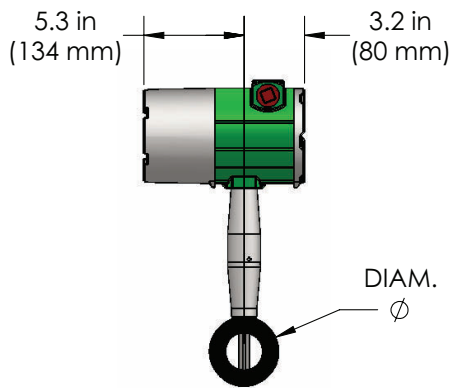
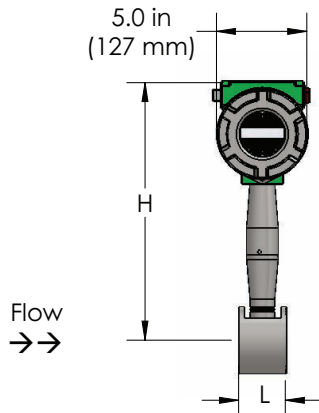

Flow Meter Nominal Size	L	H	Diameter	Approximate Weight
1/2 inch (15mm)	2.56 in (65 mm)	13.5 in (343 mm)	1.38 in (35 mm)	9.2 Lb (4.2 kg)
3/4 inch (20 mm)	2.56 in (65 mm)	13.5 in (343 mm)	1.69 in (43 mm)	9.5 Lb (4.3 kg)
1 inch (25 mm)	2.56 in (65 mm)	13.5 in (343 mm)	2.0 in (51 mm)	10.3 Lb (4.7 kg)
1-1/2 inch (40 mm)	2.56 in (65 mm)	13.8 in (351 mm)	2.88 in (73 mm)	12.1 Lb (5.5 kg)
2 inch (50 mm)	2.56 in (65 mm)	14.0 in (356 mm)	3.62 in (92 mm)	14.1 Lb (6.4 kg)
3 inch (80 mm)	2.56 in (65 mm)	14.6 in (371 mm)	5.0 in (127 mm)	18.7 Lb (8.5 kg)
4 inch (100 mm)	2.56 in (65 mm)	15.1 in (384 mm)	6.19 in (157 mm)	23.4 Lb (10.6 kg)

Add 11 lb (5 KG) for remote electronics

## Dimensional Outline RD: Pro-V™ Inline Reduced Bore Wafer Models

Flow Meter Nominal Size	L	H	Diameter	Approximate Weight
3/4 inch (20 mm) X 1/2 inch (15mm)	2.56 in (65 mm)	13.5 in (343 mm)	1.38 in (35 mm)	9.2 Lb (4.2 kg)
1 inch (25 mm) X 3/4 inch (20 mm)	2.56 in (65 mm)	13.5 in (343 mm)	1.69 in (43 mm)	9.50 Lb (4.3 kg)
1-1/2 inch (40 mm) X 1 inch (25 mm)	2.56 in (65 mm)	13.8 in (351 mm)	2.0 in (51 mm)	10.3 Lb (4.7 kg)
2 inch (50 mm) X 1-1/2 inch (40 mm)	2.56 in (65 mm)	13.8 in (351 mm)	2.88 in (73 mm)	12.1 Lb (5.5 kg)
3 inch (80 mm) X 2 inch (50 mm)	3.94 in (100 mm)	14.6 in (371 mm)	5.0 in (127 mm)	23.9 Lb (8.5 kg)
4 inch (100 mm) X 3 inch (80 mm)	4.72 in (120 mm)	15.1 in (384 mm)	6.19 in (157 mm)	35.2 Lb (10.6 kg)

Add 11 lb (5 KG) for remote electronics

## Dimensional Outline: Remote Electronics Option

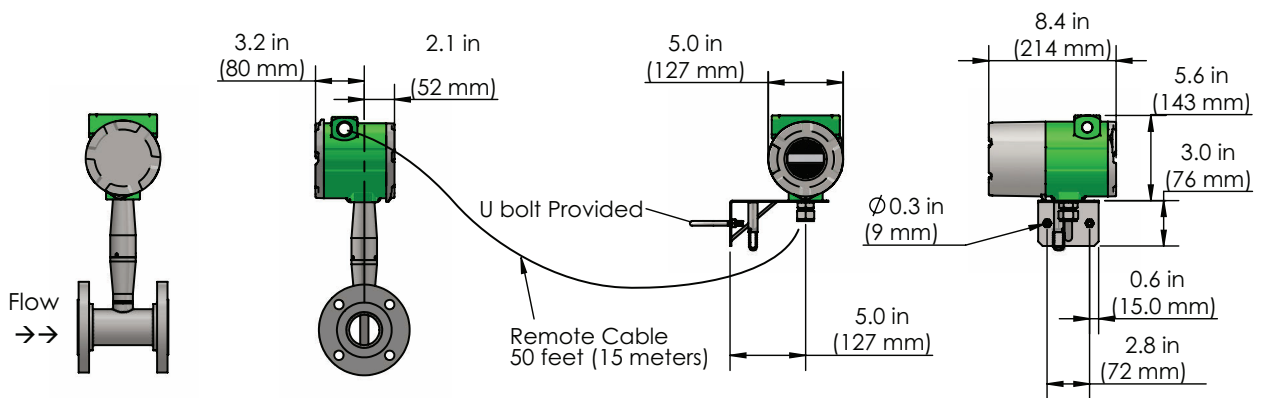

### Advantages:

- Extended measuring range for lower flow rates
- Captures steam flow in both high and low demand seasons
- Reduced installation costs
- Same face-to-face dimension as a standard vortex meter

### Extended measuring range for lower flow rates

Much of the measuring range of a standard vortex flowmeter is at higher fluid velocities. Because of this, measurements at low flow conditions may be missed due to the low flow cutoff. To remedy this issue, users often install pipe reducers and a smaller than line size vortex meter to increase fluid velocities through the meter. The M24R reduced bore vortex flowmeter has integrated reducing flanges, eliminating the need for separate pipe reducers and spool pieces.

### Captures steam flow in both high and low demand seasons

Steam usage in heating systems can vary widely based on seasonal demands.

These systems are commonly sized with the high demand season (colder weather) in mind, and little thought is given to the low demand season (warmer weather). This leads to a situation where steam flowmeters are oversized and may miss flow measurements at low flow conditions.

M24R reduced bore vortex flowmeters have an extended low flow measuring range, capturing both high and low demand seasons.

### Reduced installation costs

Like most flowmeters, vortex flowmeters have requirements for unobstructed upstream and downstream piping lengths to ensure a proper flow profile through the meter. Adding pipe reducers adds cost and complexity to the piping design since those unobstructed piping lengths are required before and after the pipe reducers.

The M24R reduced bore vortex flowmeter has integrated reducing flanges, eliminating the need for separate pipe reducers and spool pieces. Drastically reducing both the complexity and cost of the meter installation.

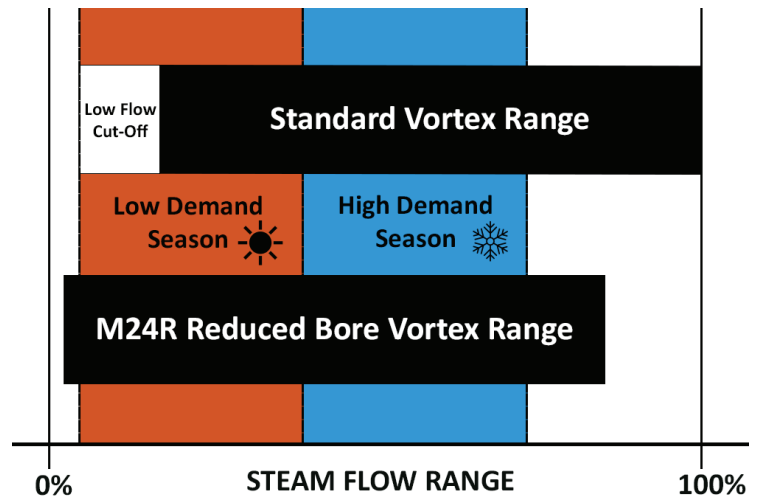

### Typical piping reduction using reducers and spool pieces

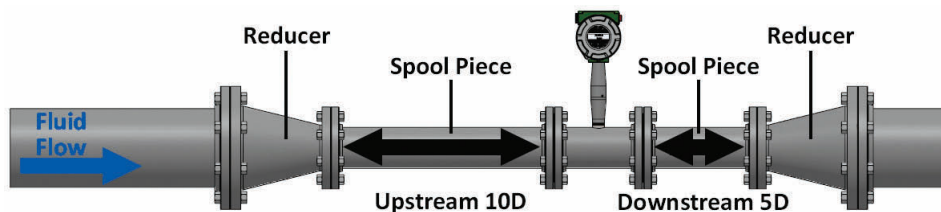

### M24R Reduced Bore Vortex with integrated reducing flanges

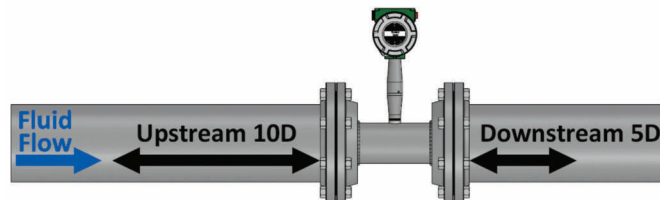

### Same face-to-face dimension as a standard vortex meter

M24R reduced bore vortex flowmeters have the same face-to-face dimension as a standard M24 meter for pressure classes up to ANSI 600. So if process conditions change, the meter size can be changed without any costly piping modifications. This is especially useful in project planning, as it allows for flexibility into the future.

## Model Number Information - Pro-V™ Model M24 Inline Mass Vortex Flowmeter

### Parent Number Code

<b>M24</b>	In-line Vortex Flow Meter
<b>M24R</b>	In-line Reduced Bore Vortex Flow Meter

### Feature 1: Multivariable Options

<b>V</b>	Volumetric Flow Meter for liquid, gas and steam
<b>VT</b>	Velocity and Temperature Sensors
<b>VTP</b>	Velocity, Temperature and Pressure Sensors
<b>VTEP</b>	Velocity, Temperature and External 4-20mA Input (T or P)
<b>VEPEP</b>	Velocity, External RTD Temperature Input, External 4-20mA Input (T or P)
<b>VT-EM</b>	Energy output options
<b>VTP-EM</b>	Energy options with Pressure Sensor
<b>VTEP-EM</b>	Velocity, Temperature and External 4-20mA Input (T or P)
<b>VEPEP-EM</b>	Velocity, External RTD Temperature Input, External 4-20mA Input (T or P)

### Feature 2: Flow Body (M24)

<b>04</b>	1/2-inch Nominal Bore (15mm)
<b>06</b>	3/4-inch Nominal Bore (20mm)
<b>08</b>	1-inch Nominal Bore (25mm)
<b>12</b>	1.5-inch Nominal Bore (40mm)
<b>16</b>	2-inch Nominal Bore (50mm)
<b>24</b>	3-inch Nominal Bore (80mm)
<b>32</b>	4-inch Nominal Bore (100mm)
<b>48</b>	6-inch Nominal Bore (150mm)
<b>64</b>	8-inch Nominal Bore (200mm)
<b>80</b>	10-inch Nominal Bore (250mm)
<b>96</b>	12-inch Nominal Bore (300mm)

### Feature 2: Reducing Flow Body (M24R)

	3/4-inch by 1/2-inch Reducing Meter (15mm)
	1-inch by 1/2-inch Reducing Meter (15mm)
	1.5-inch by 1-inch Reducing Meter (25mm)
	2-inch by 1.5-inch Reducing Meter (40mm)
	3-inch by 2-inch Reducing Meter (50mm)
	4-inch by 3-inch Reducing Meter (80mm)
	6-inch by 4-inch Reducing Meter (100mm)
	8-inch by 6-inch Reducing Meter (150mm)
	10-inch by 8-inch Reducing Meter (200mm)
	12-inch by 10-inch Reducing meter (250mm)

### Feature 3: Meter Body Material

<b>C</b>	Carbon Steel (1.5" and up)
<b>S</b>	316 Stainless Steel
<b>H</b>	Hastelloy

### Feature 4: Process Connection

<b>150</b>	ANSI 150# Flange	<b>16</b>	PN 16
<b>300</b>	ANSI 300# Flange	<b>40</b>	PN 40
<b>600</b>	ANSI 600# Flange	<b>63</b>	PN 63
<b>900</b>	ANSI 900# Flange	<b>100</b>	PN 100
<b>W</b>	Wafer ANSI 600#		

\* JIS Flanges available upon request

### Feature 5: Electronics Enclosure

<b>L</b>	NEMA 4X IP66 Enclosure
<b>R ( )</b>	Remote Electronics NEMA 4X, IP66, Specify cable length in parentheses, Standard 50 ft

### Feature 6: Display Options

<b>DD</b>	Digital Display and Programming Buttons
-----------	---

### Feature 7: Input Power

<b>DCL</b>	12-36 VDC, 25mA, 1W max. required on loop powered meters, 1AHL only
<b>DCH</b>	12-36 VDC, 300mA, 9W max. – use with 1AH, 1AM, 3AH, 3AM
<b>DCHPOE</b>	12-28 VDC or Power over Ethernet, 5 Watts maximum, required on 1AMIP, 1ABIP, 3AMIP, 3ABIP
<b>AC</b>	100-240 VAC, 50/60 Hz line power, 5W max. – use with 1AH, 1AM, 3AH, 3AM

### Feature 8: Output

<b>1AHL</b>	Loop powered option – one analog output (4-20 mA), one scaled frequency, one pulse, HART, DCL input power only
<b>1AH</b>	One analog output (4-20 mA), one alarm, one pulse, HART Communication Protocol, DCH or AC option only *
<b>1AM</b>	One analog output (4-20 mA), one alarm, one pulse, MODBUS RTU Communication Protocol, DCH or AC option only *
<b>1AMIP</b>	One analog output (4-20 mA), one alarm, one pulse, MODBUS TCP/IP Communication Protocol, DCHPOE ONLY*
<b>1AB</b>	One analog output (4-20 mA), one alarm, one pulse, BACnet MS/TP Communication Protocol, DCH or AC option only *
<b>1ABIP</b>	One analog output (4-20 mA), one alarm, one pulse, BACnet/IP Communication Protocol, DCHPOE ONLY *
<b>3AH</b>	Three analog outputs (4-20 mA), three alarms, one pulse, HART (VT,VTP only), DCH or AC option only *
<b>3AM</b>	Three analog outputs (4-20 mA), three alarms, one pulse, MODBUS RTU (VT,VTP only), DCH or AC option only *
<b>3AMIP</b>	Three analog outputs (4-20 mA), three alarms, one pulse, MODBUS TCP/IP (VT,VTP only), DCHPOE ONLY*
<b>3AB</b>	Three analog outputs (4-20 mA), three alarms, one pulse, BACnet MS/TP (VT,VTP only), DCH or AC option only *
<b>3ABIP</b>	Three analog outputs (4-20 mA), three alarms, one pulse, BACnet/IP (VT,VTP only), DCHPOE ONLY *

\*Includes scaled frequency output

### Feature 9: Temperature Options

<b>ST</b>	Standard temperature. Process temperature -330° to 500°F (-200° to 260°C)	<b>HT</b>	High temperature. Process temperature 750°F (400°C)
-----------	---	-----------	---

### Feature 10: Pressure Options

<b>P0</b>	No Pressure Sensor	<b>P3</b>	Maximum 300 psia (20 bara), Proof 600 psia (41 bara)
<b>P1</b>	Maximum 30 psia (2 bara), Proof 60 psia (4 bara)	<b>P4</b>	Maximum 500 psia (34 bara), Proof 1000 psia (64 bara)
<b>P2</b>	Maximum 100 psia (7 bara), Proof 200 psia (14 bara)	<b>P5</b>	Maximum 1500 psia (100 bara), Proof 2500 psia (175 bara)

