

- **SHORT INSTALLATION LENGTH**
- **LOW PRESSURE DROP**
- **HIGH RANGABILITY**
- **NO MOVING PARTS**

MXR desuperheaters are based on a simple and sophisticated design concept where the cooling water spray is directed between two mixing modules. The steam and uniform water droplets from the spray nozzle assembly flows through the mixing module where the combined flow is exposed to a very high contacting efficiency. Conventional desuperheaters lack an effective steam/water mixing system, thus it requires a long piece length of pipe downstream 30 feet or more of the desuperheater.

MXR desuperheaters require short length of pipe down stream and no "mixing" elbow as required by conventional units prior to the temperature probe.

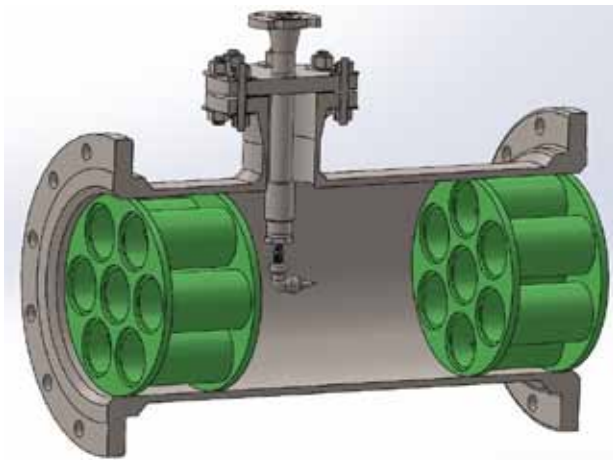

The MXR Desuperheater

Features

- Butt weld or flanged to ANSI 150, 300, 600, 900, and 2500 or DIN PN 10, 16, 40, 64, 100
- Allows spray nozzle replacement without removing desuperheater from the line
- Coolant pressure typically at least 40 psi (276 kPa) over line pressure
- Sizes available from 2" up to 60" (50 mm up to 1524 mm)
- Rangibility over 20:1 with appropriate control valve
- Temperature control to +/- 5° F (3° C)
- 100% Type 316/L SS construction
- Horizontal or vertical installation
- No thermal liners required
- Small pressure drop

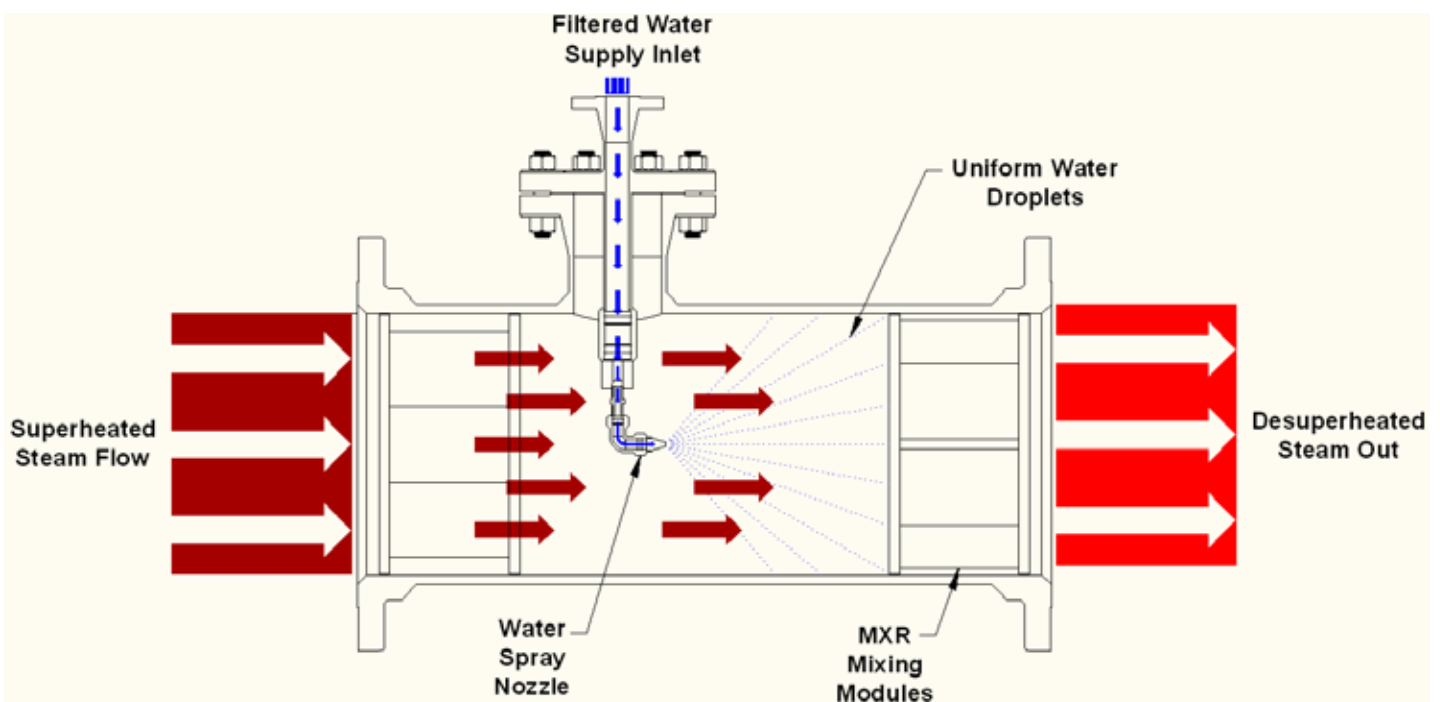

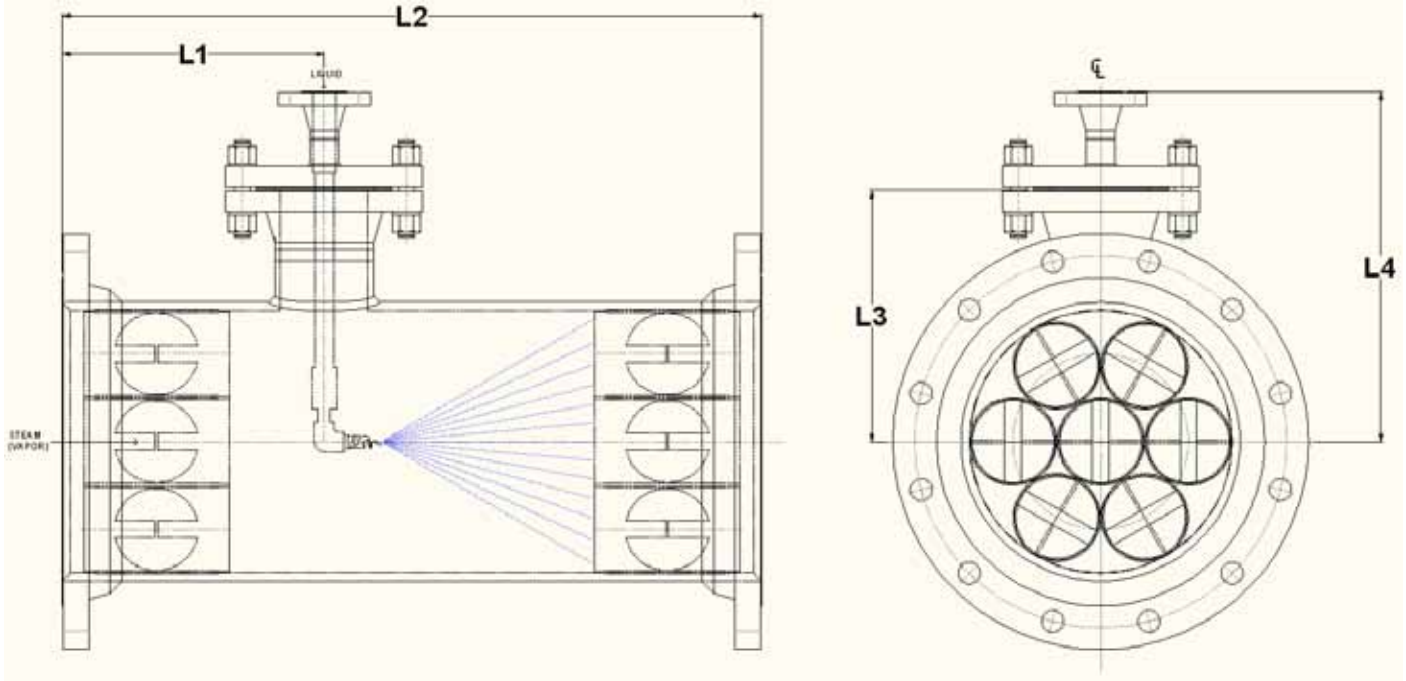

NOM. SIZE	MODEL NO.	L1	L2	L3	L4
4	DED-4-4	7.13	18.00	7.13	12.00
6	DED-6-4	9.13	22.00	8.13	13.00
8	DED-8-4	8.00	24.00	9.13	14.00
10	DED-10-4	9.00	28.00	10.25	15.00
12	DED-12-4	12.00	32.00	11.50	16.00
14	DED-14-4	14.00	36.00	12.38	17.00
16	DED-16-4	16.00	40.00	13.38	18.00
18	DED-18-4	18.00	46.00	14.75	19.00
20	DED-20-4	20.00	48.00	15.75	21.00
24	DED-24-4	24.00	60.00	18.13	23.00
ALL DIMENSIONS ARE IN INCHES					

contact:

MXR Technologies, LLC

40515 Green Oaks Dr. Temecula, CA 92592 USA

www.mxrtech.com

E-mail: info@mxrtech.com

Ph.: 1-951-303-4600 or 949-412-6525