

- **SIMPLE IN-LINE INSTALLATION**
- **RUGGED DESIGN**
- **MAINTENANCE FREE**

## MXR "DED" Series for Desuperheating

The design flexibility of MXR's Desuperheating Technologies will provide superior cooling performance in any steam desuperheating application.

## Desuperheater Applications

- Boiler Desuperheaters
- Pressure Reducing Valve Outlet Steam
- Turbine Gland Sealing
- Cooking Kettles
- Process Steam
- Process Gases
- Boiler Reheaters
- NO<sub>x</sub> Steam For Gas Turbines
- Turbine Bleed Steam
- Process Gases
- Drum Dryers
- Tire Molds

## Features & Benefits

- Requires short length of straight pipe downstream (5D to 10D)
- Very high contacting efficiency
- Turn-down ratio up to 10:1
- Low pressure drop
- Maintenance free
- Compact design
- Quiet operation

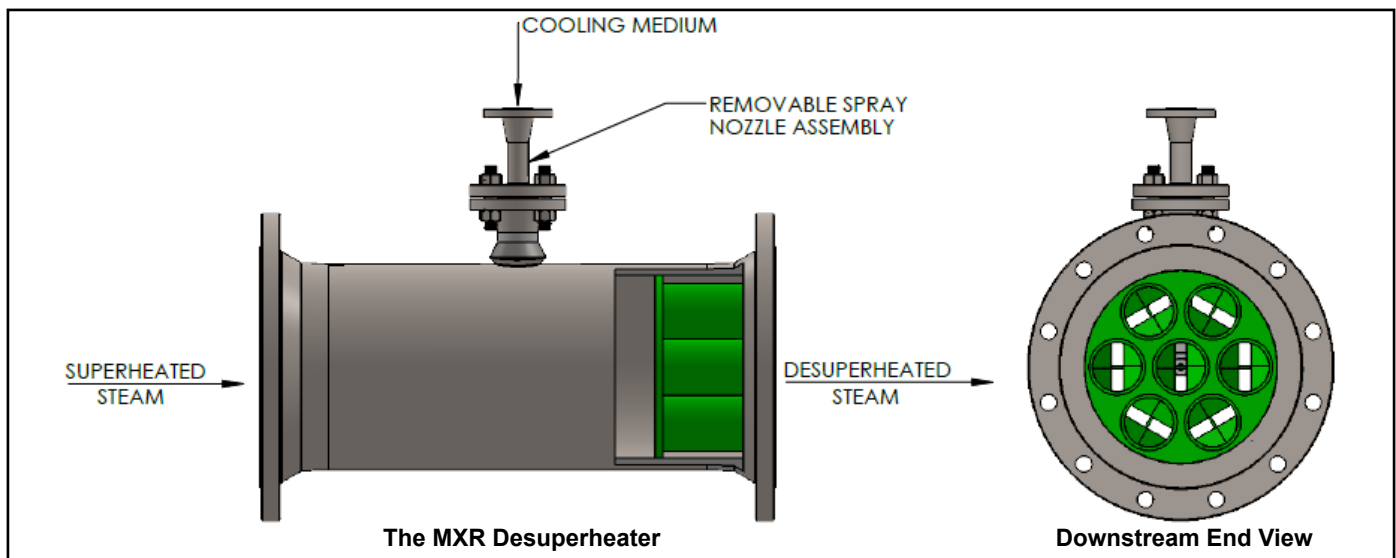

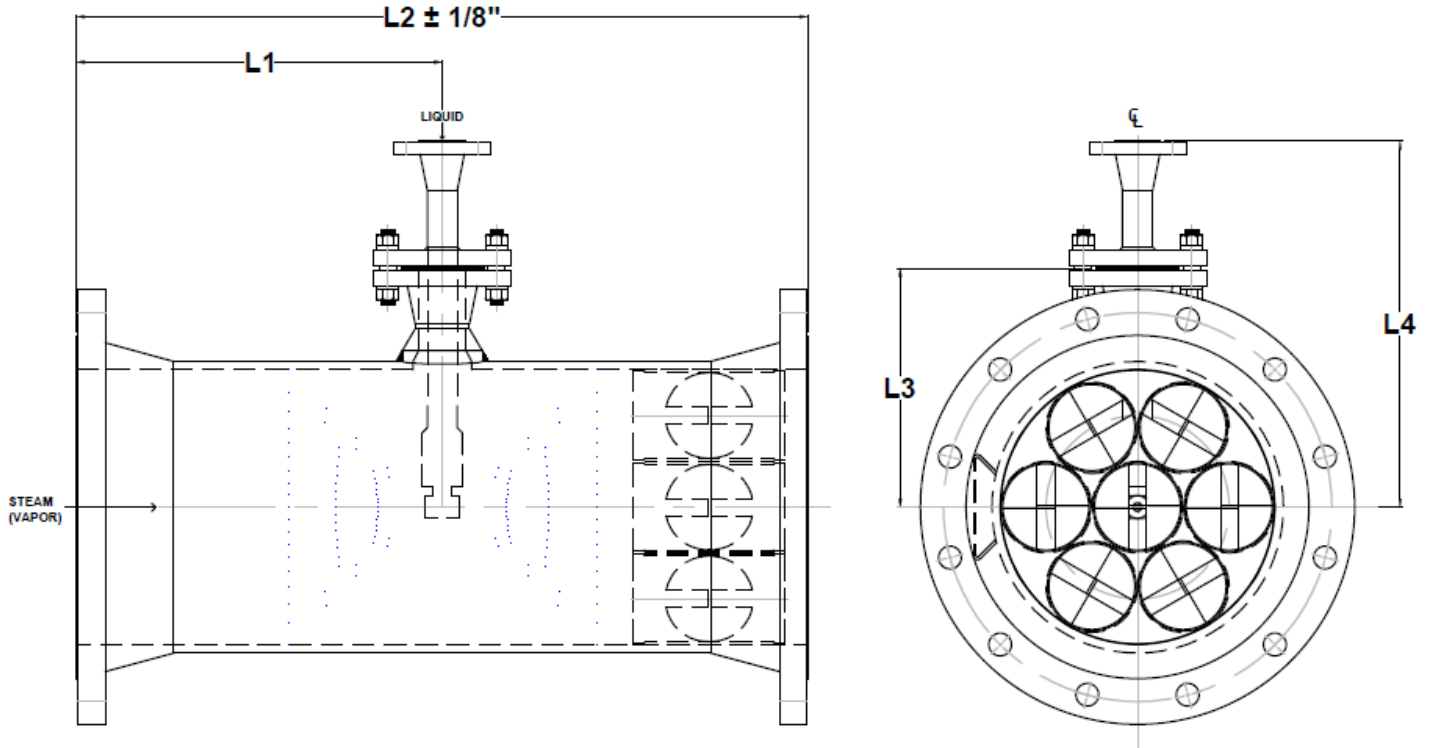

**HOUSING - PIPE:**

Standard Wall - STAINLESS STEEL - Type 316/316L

**SIDE CONNECTION - FLANGES (ANSI B16.5, CLASS 150)**

STAINLESS STEEL - Raised Face Weld Neck

**SPRAY NOZZLE ASSEMBLY (REMOVABLE):**

STAINLESS STEEL - 1" Raised Face Weld Neck Flange  
 With 2" or 3" Raised Face Weld Neck Flanged Connection  
 and 1 Special Design Spray Nozzle

**END CONNECTION - FLANGES (ANSI B16.5, CLASS 150)**

STAINLESS STEEL - Raised Face Weld Neck

**MIXING MODULE:**

STAINLESS STEEL - Type 316/316L

NOM. SIZE	L1	L2	L3	L4
4	9.00	18.00	6.31	12.00
6	11.00	22.00	7.38	13.00
8	12.00	24.00	8.38	14.00
10	14.00	28.00	9.44	15.00
12	16.00	32.00	10.44	16.00
14	18.00	36.00	11.56	17.00
16	20.00	40.00	12.56	18.00
18	23.00	46.00	13.56	19.00
20	24.00	48.00	14.56	21.00
24	30.00	60.00	16.56	23.00
ALL DIMENSIONS ARE IN INCHES				

**NOTE:** Other materials available.

Note: MXR is not affiliated with Komax.

contact:

**MXR Technologies, LLC**  
 40515 Green Oaks Dr. Temecula, CA 92592 USA  
 www.mxrtech.com  
 E-mail: info@mxrtech.com  
 Ph.: 1-951-303-4600 or 949-412-6525