

TURBOCOMPRESSOR CONTROL

# CONTROL SOLUTIONS DESIGNED TO FIT RIGHT IN

Maximizing your  
plant's efficiency  
with control systems  
built to fit your needs –  
*exactly.*

**Energy Control**   
**Technologies**

**E**nergy Control Technologies (ECT) provides the latest in turbocompressor control solutions designed to maximize your turbomachinery plant's production and efficiency. ECT engineers high value control solutions for centrifugal and axial compressors (*historically available only in proprietary hardware*) and delivers them in an open platform using Rockwell Automation hardware and software with a response time <40ms.

ECT provides solutions for centrifugal & axial compressors – surge control, performance control, Interaction Control®, and optimum load distribution of compressor networks.

### HIGH RETURN ON INVESTMENT

Turbocompressors are the heart of many processes. If the compressor is down, your process is down, costing you revenue and profit. In addition, turbocompressors are high energy users. This combination creates turbocompressor control system retrofit opportunities with high ROIs justified by production increases, fewer trips, energy savings, and lower maintenance.

Common problems that result in high ROIs:

- Compressor trips
- Compressor recycle or blow-off
- Unstable pressure control
- Controllers in manual
- Base loading of parallel or series operating compressors

### TURBOCOMPRESSOR CONTROL

Turbocompressor control is a challenging application requiring sophisticated control algorithms to operate the compressor and process safely and efficiently. ECT's TurboPAC® Turbomachinery Process Automation Control System for turbocompressors effectively solves the following control challenges:

- Accurate calculation of the distance between the operating point and surge line
- Surge control, prevention, detection, and stopping
- Control loop interaction
- Compressor network load distribution

Compressor surge is a common problem in turbocompressors that can lead to machine trips and damage. Compressors can surge in as little as 40ms with a complete surge cycle occurring in as little as one second.

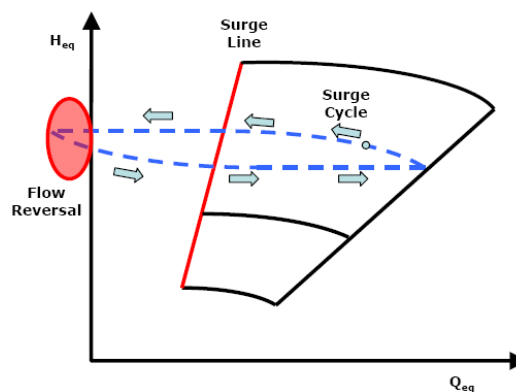

Repetitive surging can lead to seal, bearing, and rotor damage and can lead to trips based on vibration, temperature, over-speed, and exceeding process limits.

## EQUIVALENT MAP MODELS

ECT has developed a library of Equivalent Map Models to effectively deal with changing compressor inlet conditions. Our comprehensive models compensate for suction temperature, suction pressure, molecular weight, compressibility, and gas composition.

Our engineers select the models to maximize your compressor operating envelope. With this accurate compressor mapping, you'll see increases in production and energy savings through reduced recycle.

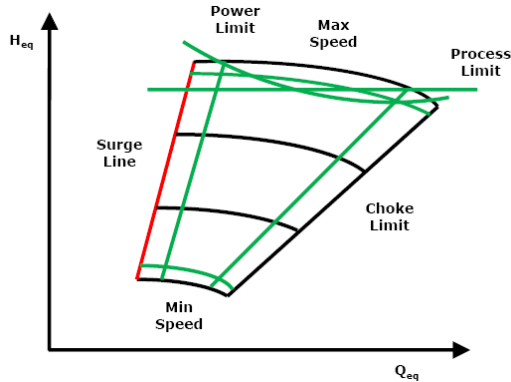

## SURGE CONTROL

ECT's SurgePAC® Surge Controller uses three specialized algorithms to prevent surge in your compressor:

- Surge Adapter®
- Surge Preventer®
- Surge Stopper®

## SURGE ADAPTER®

Surge Adapter® safely controls the compressor operating point during larger disturbances by temporarily widening the control margin, then

reducing the margin during steady state conditions, minimizing the required recycle when operating at reduced throughput.

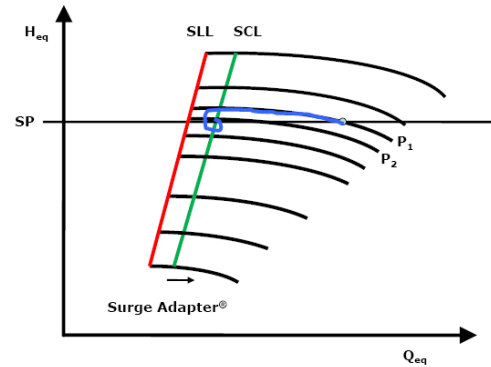

## SURGE PREVENTER®

During very large process upsets, Surge Adapter® may not be able to prevent the operating point from moving close to the Surge Limit Line (SLL). ECT's Surge Preventer® responds when the operating point crosses the Surge Preventer Line (SPL). It opens the valve quickly using Fast Response, customized to prevent surge while minimizing the process disturbance at the same time.

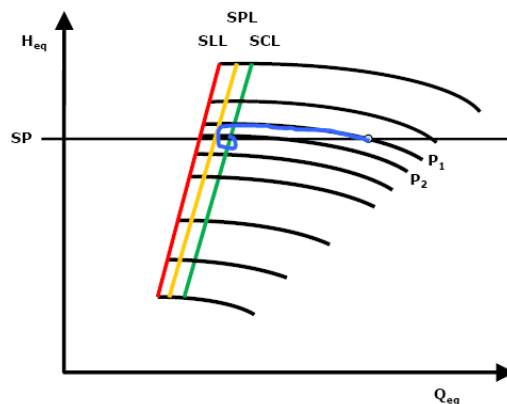

Fast Response is highly adaptable and easy to tune in the field resulting in maximum protection and quick process recovery.

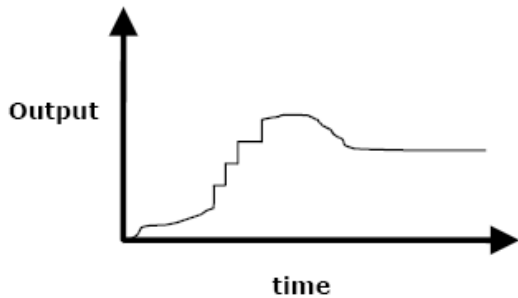

### **SURGE DETECTION AND SURGE STOPPER®**

If a compressor goes into surge, surge will be detected when the operating point crosses the Surge Detection Line (SDL). ECT's powerful Surge Stopper® control algorithm breaks the surge cycle immediately and prevents surge from occurring again.

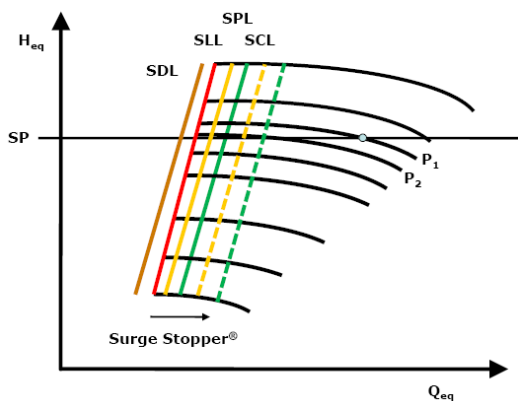

### **PERFORMANCE CONTROL**

ECT's PerformancePAC® Process Controller controls your plant's main process variable while limiting up to five additional process, performance, and mechanical constraints. The PerformancePAC® Controller can control

your turbocompressor using one or more of the following control elements:

- Inlet throttling valve
- Inlet guide vanes
- Turbine speed control
- Variable speed electric drive

### **INTERACTION CONTROL®**

Control loop interaction can be a significant problem when controlling turbocompressors. The interaction between process and surge controllers starts at the worst time, when the operating point is close to surge where the recycle valve starts to open.

Conventional systems can't cope with this problem unless they are detuned or some of the loops are switched to manual. This action results in poor process control and compromised machine protection.

ECT's Interaction Control® Algorithms eliminate control loop interactions resulting in improved process and surge control stability while keeping all controllers in automatic.

### **COMPRESSOR NETWORKS**

One of the more challenging applications in controlling compressors is load distribution of compressors operating in parallel or series.

ECT's Network Control System includes a Supervisor Function and Distribution Function.

The Supervisor Function is designed to control the main network process variable, usually suction header

pressure, discharge header pressure, or system mass flow. The Distribution Function distributes the load among the compressors in the network to maximize compressor network production, efficiency, protection, and stability.

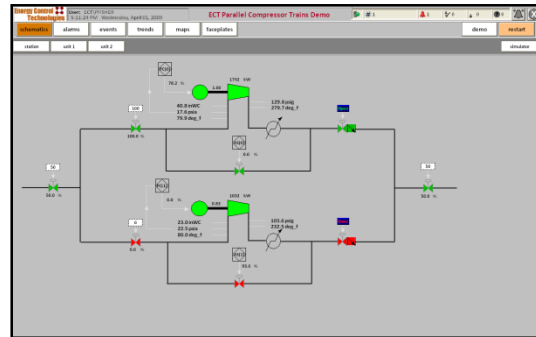

ECT's turbomachinery diagram

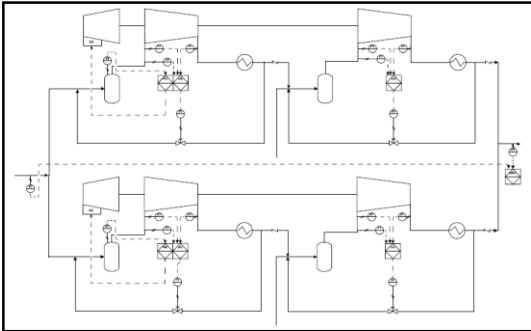

ECT's Network Control System operating two parallel – two section compressor trains

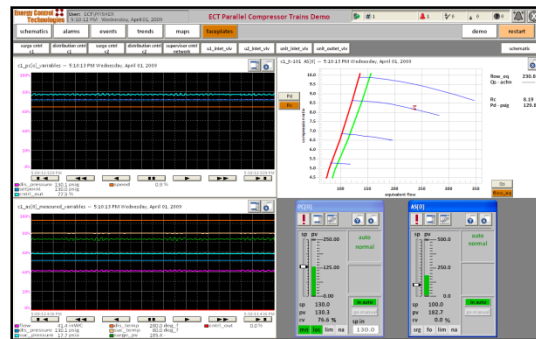

ECT's trends, dynamic compressor map and controller face plates

## TURBO PACVIEW®

ECT's Turbo PACView® is your window into your turbomachinery plant enhancing operation, maintenance, and monitoring functions. With high resolution data recording capability, Turbo PACView® can capture critical data that you can replay for troubleshooting purposes. Our engineers customize your Turbo PACView® with the following features:

- Turbomachinery diagram
- Dynamic compressor map
- Controller faceplates
- High speed trending
- Event-driven fast archiving
- Alarms and events

## FAULT TOLERANCE

ECT provides a fully redundant control system that is SIL 2 compliant. In addition, ECT's Fault Tolerant Control Action keeps your system running even with failures of non redundant transmitter inputs.

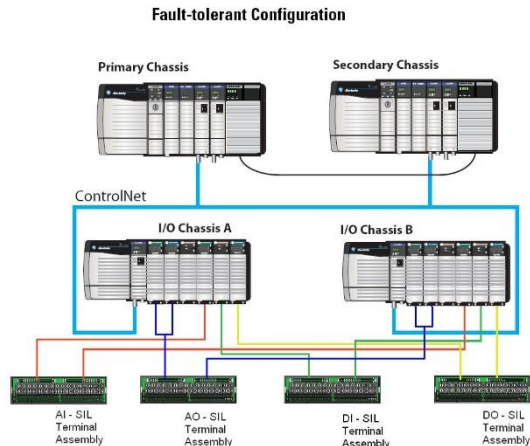

## NEW CONSTRUCTION AND RETROFIT PROJECT SERVICES

ECT supports our customers' projects with expertise, from pre-feed control system development to system commissioning, through:

- Applications engineering and consulting
- Site surveys
- Economic justifications
- Project engineering
- Factory acceptance tests
- Field service and commissioning
- Installation supervision
- Simulations
- Training
- Service contracts



*ECT's engineers review field-mounted devices for optimum control system performance.*

ECT provides site surveys and economic justifications on retrofits and upgrades to justify customer investments in new control systems.

ECT supports our customers during the engineering phase of the project eliminating the guess work on valve sizing, transmitter selection and locations, process equipment sizing and piping layout through high-fidelity simulations.

ECT provides full field service support from system checkout to commissioning including onsite surge testing and tuning of your system. ECT also has the capability to provide remote field support using the latest technology.



*ECT provides full field service support, from checkout to commissioning and remote support for system troubleshooting.*

## PUT ECT TO WORK FOR YOU

Whether it's a site survey to calculate an ROI for a retrofit or to help you with important decisions on piping layout and vessel locations on a new project, ECT is ready to support you on your next turbomachinery control system project.

Contact ECT today at:

Energy Control Technologies, Inc.  
2751 99<sup>th</sup> Street  
Urbandale, IA 50322  
515 223-1635

[contactus@energycontroltechnologies.com](mailto:contactus@energycontroltechnologies.com)

Or visit us on the web at:

[www.energycontroltechnologies.com](http://www.energycontroltechnologies.com)

**Energy Control**   
**Technologies**