

---

# System 9000TS Sequence of Events Recorder

---

## 1ms Event Recorder and combined Annunciator

---

**Modular, rack mounting design  
expandable to over 4000 inputs**

**1mS time stamping of events  
across the whole system**

**Up to 15,000 events stored per  
rack in distributed non-volatile  
memory**

**Flexible auto-shelving facility to  
avoid nuisance alarms**

**Fully programmable via the  
programming port on the  
Interface Card using Windows-  
based configuration software**

**Fully integrated alarm annunciator  
functionality**

**Wide range of optional displays**

---

The System 9000TS Sequence of Events Recorder leads the way in the latest technically advanced event and alarm management systems.

Built on a rugged hardware platform suitable for the most severe of industrial environments this unit will provide true time-stamping of event occurrence to a resolution of 1ms. Using the synchronization input this can also be related to real time.

Using the optional integrated alarm annunciator features it is possible to build a system that will capture, record, print and display events and alarms both for immediate action on the plant and for later analysis to find the prime cause of the failure.

The system is available with various different display and output options to suit individual applications.



# Features & Benefits

- ▶ Provides independent annunciation and time stamping of critical plant alarms while communicating back to the host DCS, PLC, ESD, SCADA or computer system
- ▶ Fully programmable, for all system features which can be stored and downloaded as required via the integral Interface Card
- ▶ Suitable for systems from a sixteen-input package to a plant-wide alarm/recording system
- ▶ Total flexibility in choice of system size, display style, operation and options
- ▶ Field proven technology, with hundreds of thousands of alarm points already in operation worldwide

**With personnel safety, increased regulation and the high cost of plant shutdowns the need to continuously monitor, record and analyze system performance has become more important than ever before.**

**The traditional back-lit annunciator will provide the clearest method of alerting the operator this can now be combined with accurate time tagging of the events. In the automated control and protection used in today's modern plant a typical failure can result in alarm bursts of over 100 alarms within the first few seconds. The key issue in these situations is not only to identify the alarms and inform the operator but also to identify the primary cause of failure within the process.**

**The System 9000TS has been developed with this in mind and will capture a change in state on digital events across the entire network to within a 1mS resolution.**

## **Total Configurability**

All the facilities are field programmable using RTK's Windows-based setup software provided with the equipment.

All features are configurable for each individual input and output channel and can easily be set-up in minutes without the need to learn a special programming language.

All the alarm sequences specified in the ISA publication "Annunciator Sequences and Specifications" are available in addition to a wide range of additional features.

## **Total Flexibility**

The modular construction and the advanced programming facilities mean that the System 9000TS combined SER and alarm system can be supplied to match any process alarm application. Standard 19" Racks provide almost

unlimited system expansion and the user can configure each channel from a range of pre-defined features and embedded sequences as required. Configuration changes can easily be generated off-line and downloaded.

## **High Density Packaging**

Standard 3U 19" Racks with rear access terminals are used on the System 9000TS. The first rack houses the Interface Card and up to 13 slots of Sixteen Channel Input/Output Cards. Extension racks are suitable for 14 slots of Sixteen Channel Input/Output Cards.

Multiple racks are interconnected using factory supplied ribbon cables/connectors to form large systems up to 4000 channels.

## **Interfacing**

The System 9000TS is ideally suited to interface to third party plant equipment. Systems are always supplied with a Modbus RS485 serial interface and options exist for Ethernet and protocol converters.

Eight system relays are provided as standard for use as watchdog, system faults, horn and group relays. Individual repeat relays for each channel can be provided as an option

Using the powerful communications features it is possible to interface to existing PLCs, SCADA systems, Emergency Shutdown Systems and plant-wide distributed control systems.

The Annunciator can monitor and display critical alarms and communicate the results into the normal monitoring systems, giving another level of safety and independence from the general monitoring or control system.

## **Event Storage**

The system has a unique distributed method of storing events so that even following a cascade of alarms or a power failure up to 15,000 events per rack are stored within the solid-state, non-volatile memory.

## **Expandability**

Each 19" rack is supplied fully equipped allowing simple expansion with the addition of Input, Output or Relay Cards. If a larger system is required additional racks can be interconnected to the existing unit using factory supplied ribbon cables and connectors to link system features.

## **Interface Card**

Each system is supplied with an Interface Card. Customer connections for remote printing and programming are provided on the front of this card.

Configurable system relay outputs and the RS485 serial output are available on the rear of the associated chassis. Once configured, settings are stored on EEPROM on the individual cards.

In addition, the Interface Card filters and protects the incoming 24VDC supply and provides real time synchronization to the system.

## **Nuisance Alarms**

Each alarm can be set to automatically inhibit (shelve) if the alarm frequency exceeds configured parameters and are therefore considered invalid. Alarms are automatically re-instated once they return to normal patterns.



# Features & Benefits

## Isolation

All customer inputs to the system are provided with optical isolation. This enables the system to operate without deterioration or disturbance in environments of extreme electrical noise.

## Inputs

Each optically-coupled input can be set to operate from a normally open or normally closed volt free contact powered via the annunciator at 24VDC. Alternative configurations are available for direct powered inputs from 24V, 48V, 110V and 250V AC/DC if required.

## Servicing

All alarm points are configured by plugging into the programming port on the Interface Card and downloading the settings from the Windows Setup Software supplied with the system. In the unlikely event of a card failure a new card installed into the system will be automatically configured to the original configuration.

## Mounting

Industry standard 3U 19" racks with rear access, rising clamp terminals mounted on the rear of the chassis for customer wiring. As an option quick disconnect terminals with locking screws are available.

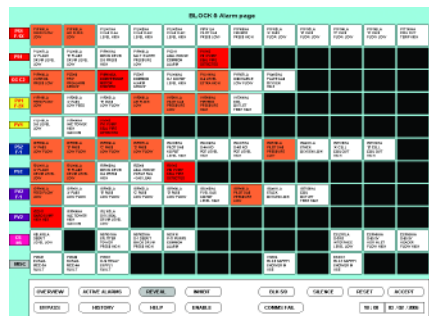

ALARM	STATUS	DESCRIPTION	GROUP	DELAY	PRIORITY	CONTROL
1	OK	Normal	1	0s	Low	None
2	OK	Normal	1	0s	Low	None
3	OK	Normal	1	0s	Low	None
4	OK	Normal	1	0s	Low	None
5	OK	Normal	1	0s	Low	None
6	OK	Normal	1	0s	Low	None
7	OK	Normal	1	0s	Low	None
8	OK	Normal	1	0s	Low	None
9	OK	Normal	1	0s	Low	None
10	OK	Normal	1	0s	Low	None
11	OK	Normal	1	0s	Low	None
12	OK	Normal	1	0s	Low	None
13	OK	Normal	1	0s	Low	None
14	OK	Normal	1	0s	Low	None
15	OK	Normal	1	0s	Low	None
16	OK	Normal	1	0s	Low	None
17	OK	Normal	1	0s	Low	None
18	OK	Normal	1	0s	Low	None
19	OK	Normal	1	0s	Low	None
20	OK	Normal	1	0s	Low	None
21	OK	Normal	1	0s	Low	None
22	OK	Normal	1	0s	Low	None
23	OK	Normal	1	0s	Low	None
24	OK	Normal	1	0s	Low	None
25	OK	Normal	1	0s	Low	None
26	OK	Normal	1	0s	Low	None
27	OK	Normal	1	0s	Low	None
28	OK	Normal	1	0s	Low	None
29	OK	Normal	1	0s	Low	None
30	OK	Normal	1	0s	Low	None
31	OK	Normal	1	0s	Low	None
32	OK	Normal	1	0s	Low	None
33	OK	Normal	1	0s	Low	None
34	OK	Normal	1	0s	Low	None
35	OK	Normal	1	0s	Low	None
36	OK	Normal	1	0s	Low	None
37	OK	Normal	1	0s	Low	None
38	OK	Normal	1	0s	Low	None
39	OK	Normal	1	0s	Low	None
40	OK	Normal	1	0s	Low	None
41	OK	Normal	1	0s	Low	None
42	OK	Normal	1	0s	Low	None
43	OK	Normal	1	0s	Low	None
44	OK	Normal	1	0s	Low	None
45	OK	Normal	1	0s	Low	None
46	OK	Normal	1	0s	Low	None
47	OK	Normal	1	0s	Low	None
48	OK	Normal	1	0s	Low	None
49	OK	Normal	1	0s	Low	None
50	OK	Normal	1	0s	Low	None

## Power Supply

The supply voltage range for the system is wide enough for unregulated and battery backed supplies. The nominal 24V DC supply can be anywhere within the range 19-36V DC without affecting system performance.

## Reprogramming

The cost of replacement ICs and on-site visits to change cards is completely eliminated with the System 9000TS. All functions can be easily and permanently changed using the setup software provided with the system. No special programming skills are required, features are simply enabled or disabled in software.



## Pushbutton Inputs

The standard requirement for the majority of alarm annunciators is 3 pushbuttons for Lamp Test, Accept and Reset. The System 9000TS provides these functions as standard and 5 additional control inputs are available for more complex applications if required. The additional control inputs can be enabled or disabled using the RTK supplied software utility. The additional functions are Silence, System Test, First-up Reset, Sleep and Horn Inhibit.

## Card Types

### Interface Card (P925TS-X)

Provides a link between the system I/O and the outside world with the following outputs

- ▶ RS485 serial port
- ▶ Power input
- ▶ Parallel printer port
- ▶ Synchronisation
- ▶ Programming port

### Input Card (P925TS-I)

Connects to the alarm and pushbutton inputs, time-stamps to 1ms and buffers the events

### Output Card (P925TS-O)

Provide the drive to external display facia to show alarm information to standard ISA sequences

### Relay Card (P925TS-R)

This card is driven from the Input Card and gives an individual repeat relay per alarm input.

## Relay Outputs

The standard system has outputs for all the commonly used functions, such as horn, watchdog, group and system fault relays. The watchdog relay is always provided, this will trip if any general fault occurs with the electronics. In addition to this there are eight further configurable relays which can be set as required up to a maximum of 8 group relays, 4 horn relays or various system fault relays. Each alarm way can also be supplied with individual repeat relay outputs, user configurable to follow the alarm contact or follow the alarm logic.

## Displays

The System 9000TS is designed to work with almost any type of remote display ie. conventional backlit lamp or LED displays individual panel lamps or mimic diagrams RTK Instruments offer a range of display products to complement the 9000TS, these are detailed in the Display Facias datasheet.

## Combined Alarm System

The System 9000TS can be supplied as a standalone Sequence of Events Recorder or with Output Cards which will provide a fully integrated alarm and event management system. Various card combinations are available to build up systems to suit the exact application.

## Advanced Communications

All systems are supplied with the RS485 communications feature in addition to outputs for printers, programming and synchronization. These outputs are available to link to the wider plant equipment to log and store events and alarms as they occur for later analysis if required. Additional communications will also be available to provide ethernet, profibus, dual redundant communications etc.

## Fully Programmable

Each input channel can be set to suit individual applications, for example: input time delay, alarm sequence, priority, grouping, and channel description. All these features can be enabled or disabled and stored using the RTK supplied configuration software. System parameters can be easily stored for retrieval at a later date if required.

## Flexible System designs

RTK can supply the 9000TS system components as loose items for integration by others or fully integrated within industry standard wall mounting or floor standing panels configured to individual specifications.

# Software and Printing Facilities

The majority of the features listed are supplied as standard as part of the normal software. This allows the system to be configured to match individual applications, RTK also offer full software integration enabling us to provide complete systems, undertake programming and commissioning. Please consult our Sales Office for further information on Alarm Management Software solutions.

## Event Storage



The S9000TS uses an advanced, powerful inbuilt processor system complete with non-volatile memory to store both system settings and event and alarm data. The data storage system is designed without using any components with moving parts such as Hard Disk drives to provide the greatest system reliability possible. The software is programmed for all the system settings via the front mounted programming port using a standard RS232 output from a standard PC.

## System Setup

The RTK supplied configuration software allows the user to enable/disable features and assign alarm text ie.

- ▶ 60 character of text for alarm messages
- ▶ Event prefix for both alarm and return to normal states
- ▶ Normally open or closed inputs
- ▶ Input time delays
- ▶ Alarm priorities
- ▶ Printer setting
- ▶ Auto-shelve parameters
- ▶ Assigning group and common relays

## Printers

All systems can be supplied with a local printer to provide and immediate record of alarm and return to normal states. As an option systems can be supplied suitable for connection via modem or Ethernet to remote printers. Configuration settings, summary and status reports can be printed on demand.

## Software Options

With its advanced communications facility the System 9000TS is an ideal front-end to a screen based alarm management /recording system. RTK can provide Alarm Management Software and complete systems using industrialized computers and screens. These are developed in conjunction with the users to provide the clearest possible means of showing alarms, the priority of these alarms and exactly what to do in each alarm situation. These systems can also provide a means of displaying/storing all alarm and event history for analysis at a later date.

## Timers

Delay timers can be incorporated into the System 9000TS on both the inputs and the outputs. This facility can avoid the possibility of nuisance alarms by setting an input time delay from 1mS to 65,000mS. Using this setting the alarm contact must be in alarm for a pre-determined minimum time before triggering the input circuitry while still maintaining an exact record of the time of the original event. For example, if an alarm occurs but it is dealt with and

## The Best of Both Worlds

Ideally, critical plant alarms should be hard wired to a dedicated Alarm and Event Recording System like the System 9000TS and data passed onto the DCS as a secondary function. This offers the best of both worlds in that the System 9000TS, which has been specially developed to offer high speed event capture and True First Out Discrimination, also provides the clearest possible indication of critical plant conditions.

The System 9000TS provides an independent, highly reliable, modular alarm system employing multiple redundant design features which should be used to complement centralized DCS platforms that have been primarily developed for control and monitoring.

accepted, the remote telemetry system will not need to be notified.

## Complete Systems

RTK can provide the System 9000TS in a wall mounted or floor standing cabinet and provide all the necessary wiring to the displays, PSU's and terminals ready for final installation on site. These panels are quoted against each specific customer requirement; please contact the Sales Office for further details.

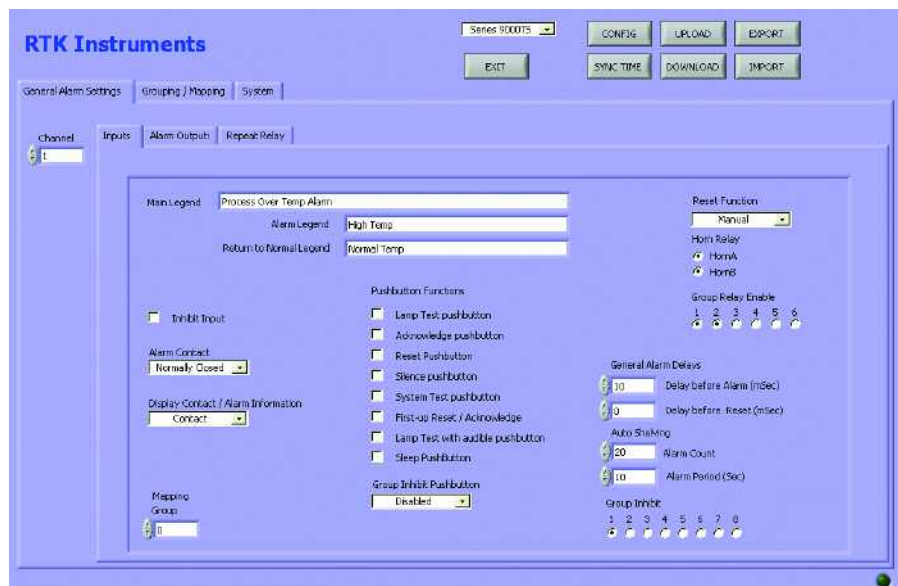

# Displays

To complement the System 9000TS Alarm Annunciator, RTK Instruments offers a wide range of displays from simple lamp arrays to full mosaic mimic panels. Most of the displays are modular in design to enable RTK to match your exact needs,

rather than compromising on the nearest available shape and size. The main display types are illustrated and described here; for more detailed information, refer to the separate display datasheet.



## P725LO Lamp-Only Modules

This display has been designed to match the Series 725 Alarm Annunciator – it will look identical when viewed from the front. It is available in exactly the same format as the Annunciator with three window sizes, six colours and a choice of lamp or LED illumination. This display is the best choice when LED illumination is required, offering the most competitive ultra-bright illumination. It is fitted with a 'Lamp Test' facility as standard.

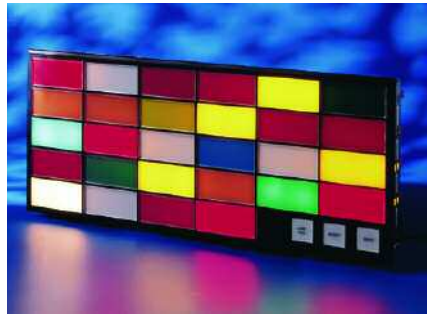

## DF30 Display Facia

The DF30 display facia provides a flexible display panel for both LED or incandescent lamps. This display facia is totally modular allowing systems of almost any shape and size to be constructed. The basic lamp module is 1.18" x 1.18" (30 x 30mm) but these can be configured to give a range of window shapes and sizes by interconnecting multiple windows. This display can also have integral pushbuttons, keyswitches and audible devices. There is no limit to the number or position of these devices. All connections are by rear mounted screw terminals.



## Hazardous Area Displays

When supplied through suitable certified interface devices, the System 9000TS can be used to drive a display facia in the hazardous area. The DF30IS is a backlit display certified as Ex II 1G, EEx ia IIC T4. The display gives a bright LED illuminated backlit display that matches the safe area versions.

The L20 Intrinsically Safe Multiplexer can also be used to drive a hazardous area display using only two cables into the hazardous area.

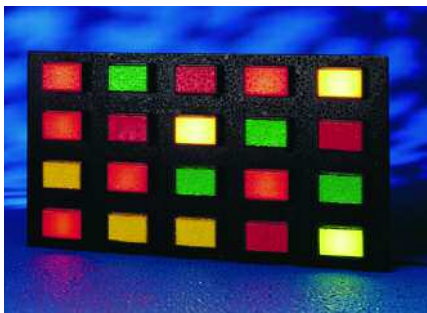

## IP65 Displays

Where protection from the environment is essential a range of displays sealed to IP65 can be provided. These custom-built units have bright LED display modules wired to rear mounted terminals. The completed assembly is mounted with a gasket to the panel door to maintain the sealing.

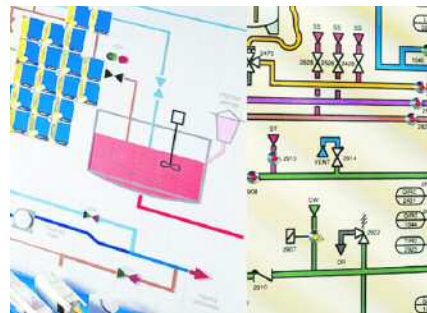

## Mimic Displays

Mosaic tiled mimic systems can be driven by the System 9000TS to provide a flexible and informative overview display. The standard mosaic mimic uses a .95" or .98" (24 or 25mm) tile mounted on a strong aluminium honeycomb grid. Tiles are the moulded type for process mimics or alternatively screen-printed or engraved to form the required display drawing. A wide range of suitable lamps, switches, pushbuttons and displays can also be integrated into the finished mimic. On smaller projects and simpler display requirements a hard wearing, single piece mimic can also be provided.

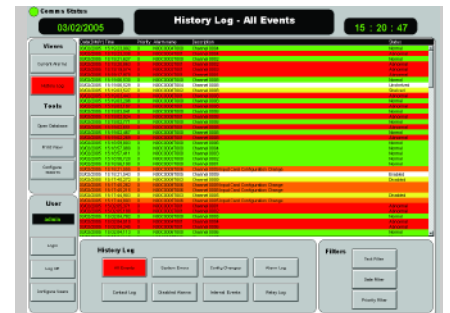

## Alarm Management Software

With its multi-redundant architecture and communications facility the System 9000TS is an ideal front-end to a screen based Alarm Management System. These can be set up in thousands of different ways to suit each individual alarm handling situation. Different display screens have already been developed and these building blocks would be used to provide a custom solution for each client. These systems could also incorporate touch screen displays, dual redundant servers and a range of industrial computers.

# Advanced Annunciator Features

When combined with the Output Cards the S9000TS becomes a powerful Alarm Annunciator system, some of the commonly used alarm functions available are shown below

## Repeat Relays

Each alarm point can have an individual repeat relay output in addition to any group relays configured. The relays can be set to be energised or de-energised and as N/O or N/C contact. The relay functions are also user configurable to follow the alarm logic or follow the input.

## Output Relay Reflash

Each of the group relays can have a reflash facility enabled. This is where the group relay will change state for 500ms when another alarm within the group occurs. This allows a control room annunciator or monitoring system to indicate each occurrence of a new alarm.

## Multiplexer

To cut down on the costs of installing vast numbers of cables across large sites, the System 9000TS can be used as an economical multiplexer system, where all the input contacts are gathered by a single System 9000TS-TX Module and transmitted serially on 4 wires up to 4,000ft (1.2 km) away to the receiving module, the System 9000TS-RX Module. The alarms can then be displayed on a display facia or within alarm management software packages.

## Sleep Mode

Useful in unmanned/not normally manned situations. Any input can be configured as a "sleep" input. When this input is switched on the drive outputs to the lamps and audibles are disabled. The annunciator will work exactly the same in all other respects; all alarms are

monitored as standard and all repeat relays and communications function as normal. As soon as the system is switched out of the "sleep" mode, the display fascias will display all alarm information, complete with all first-up details.

## First Up

In alarm annunciation applications, it is often essential to know which alarm occurred first. For this reason, the System 9000TS can be supplied with a flexible high resolution first-up facility as standard. Four different first-up sequences are provided to match the ISA standard S18-1 1979 (R 1984). Up to four separate first-up groups can be defined within the one system; each alarm way can be configured as being in one of these four groups.

# Sequence Tables

Each alarm channel can be configured to suit the operating sequence required as listed in the ISA publication *Annunciator*

*Sequences and Specifications S18.1 1979 (R1985)*. Systems can be configured with different features on different alarm ways

and there is no need to switch the power off. The diagram below shows the most commonly used sequences.

## MANUAL RESET

## Sequence Code M

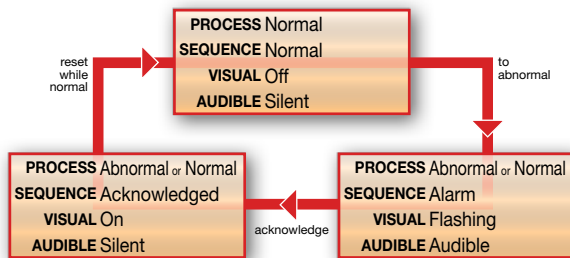

## AUTOMATIC RESET

## Sequence Code A

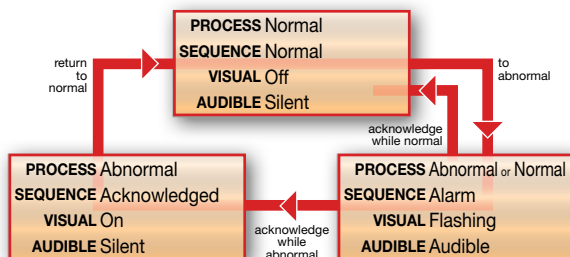

## AUTOMATIC RESET FIRST OUT WITH FIRST OUT FLASHING AND RESET PUSHBUTTON

## Sequence F3A

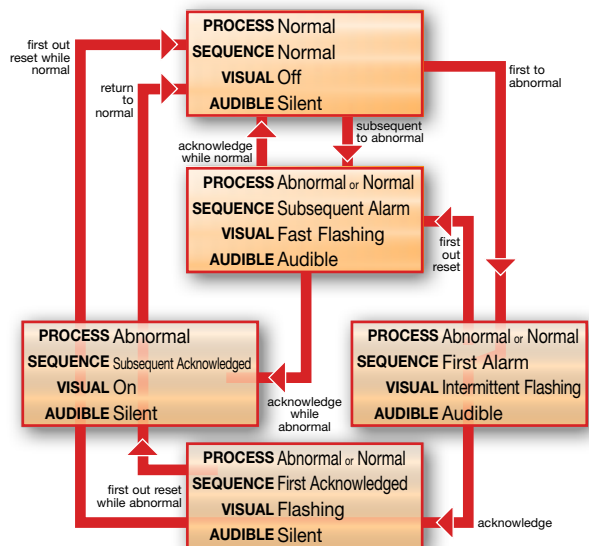

# Installation and Mechanical Details

## Standard System

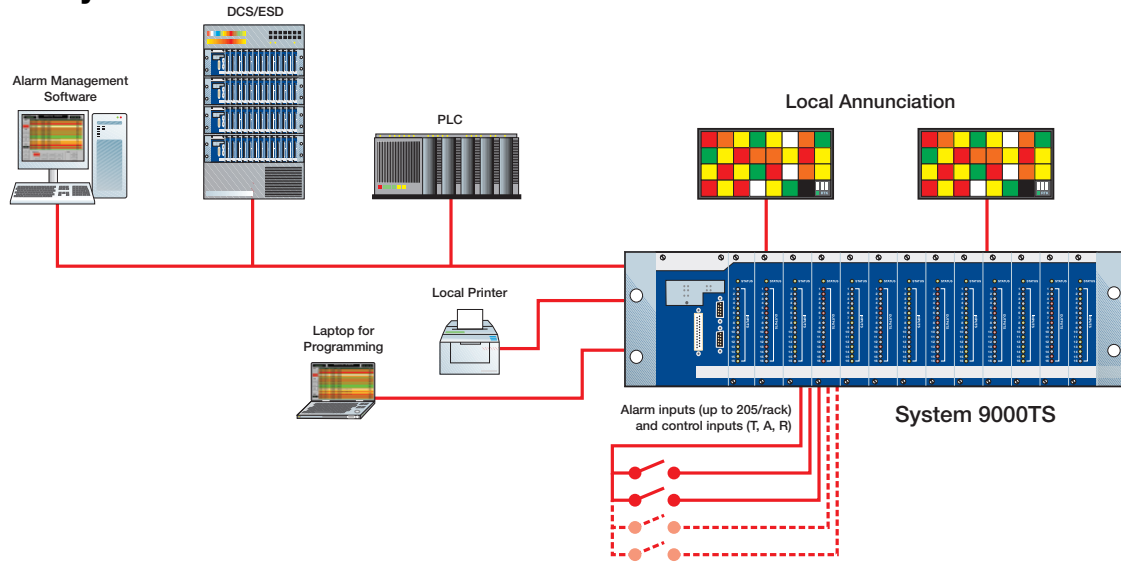

## Networked System

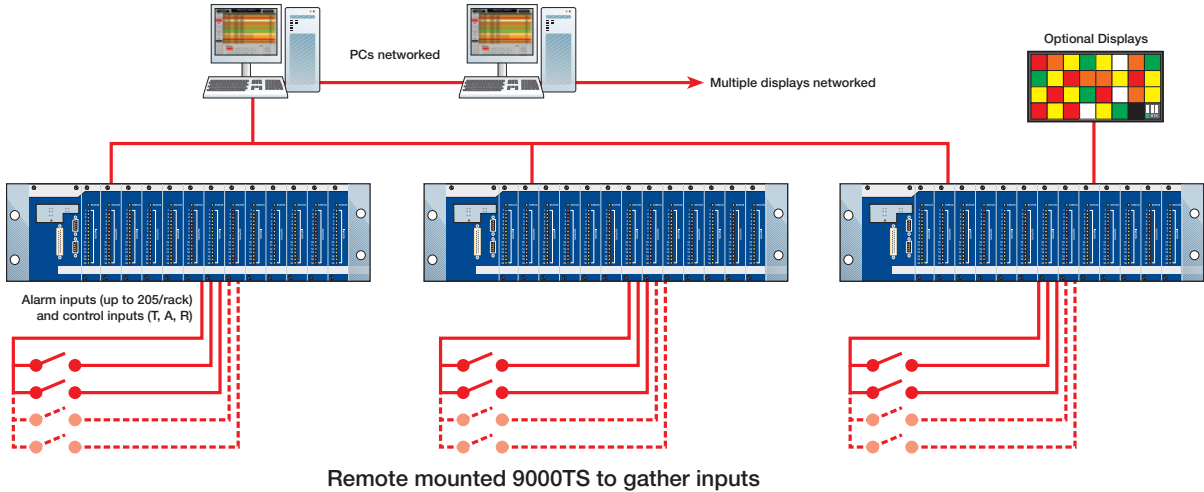

The System 900TS is based on the standard eurorack, manufactured to IEC 297-3 (DIN 1494 Pt.5). The standard subrack size is 3U and 19" wide.

This module will fit the Interface Card and up to 13 Input Cards. Larger systems can be supplied by interconnecting multiple racks. All signals are fully buffered

between racks, so no signal deterioration will occur even on extremely large systems.

## Thirteen module, full 19" rack

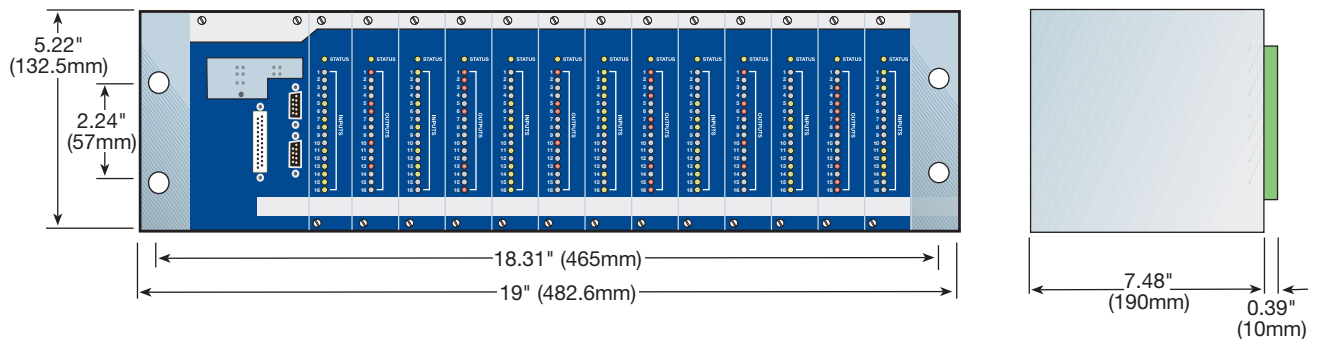

# Technical Specification

## Inputs

### Alarm Contacts

All inputs are opto-isolated (isolation voltage 2.5kV). By using different wiring configurations, the same system can be used for both:

- ▶ Volt-free contacts which can have the operating mode configured using the Setup Card, to operate to alarm for contact open or to alarm for contact close.
- ▶ Voltage input from 24, 48, 110 or 250VAC/DC.

### Alarm contact and cable resistance

N/C contact – series resistance of contact cables 20kΩ maximum.

N/O contact – parallel resistance of contact cables 200kΩ minimum.

### Field contact voltage and current

The voltage for volt-free alarm contacts is fed from the unit at 24VDC at approximately 2mA.

To maintain complete isolation it is possible to use a separate PSU to feed all the alarm contacts.

### Overall system resolution

1ms

### First-up Discrimination

1ms

### Alarm Clearance Discrimination

1ms

### Control Inputs

Any input can be configured to one of the following control inputs:

- ▶ Lamp test
- ▶ Acknowledge
- ▶ Reset
- ▶ System test
- ▶ Silence
- ▶ First-up reset
- ▶ Sleep
- ▶ Horn Inhibit

## Outputs

### Lamp Drive (when Output Cards fitted)

Each output can drive up to 160mA at 24VDC, making it suitable for multi bulb displays or multiple repeat displays.

### Standard Relays

Eight standard relays fitted on the Interface Card, these are configurable as system alarms such as watchdog, printer fault etc or group alarms.

Contact rating at 220VDC (250VAC) max, 125VDC @ 0.5A, 24VDC @ 2A, resistive. Selection of N/O or N/C contact by jumper link.

### Repeat and Group Relays

Group relay card and individual repeat relays for each alarm way. Contact rating at 220VDC (250VAC) max, 125VDC @ 0.5A, 24VDC @ 2A, resistive.

### Synchronization

By pulse, IRIG-B or GPS signal

### Printer Port

Standard parallel port

### Serial Data

Event/alarm data can be transmitted using the serial communications port to other System 9000TS units, DCS systems, PLCs or computers.

Transmission – RS485C. Full duplex, 1 start bit, 7 data bits, 1 parity, 1 stop bit.

Baud Rate – up to 9600

Protocol – ASCII MODBUS and RTU

## General

### Supply Voltage

24VDC nominal (19–36VDC) Standard

A range of power supplies is available to convert from other AC or DC voltages.

### Supply Current (mA) **24V**

Quiescent: Interface Card 150

Quiescent: Input Card 50

Relay current/per relay 22

Add the current for the lamp drive to the totals of the above cards



### EMC Compliance

Immunity to EN61000-6-2:2001  
Emissions to EN61000-6-4:2001

### LVD Compliance

The unit is designed and manufactured to safety specification  
BS EN61010-1:1993

### Environment

Operating temperature –4°F to +140°F  
(–20°C to +60°C)  
Storage temperature –4°F to +176°F  
(–20°C to +80°C)  
Humidity 0–95% RH, non-condensing

### Mechanical Details

19in Rack  
Standard 3U by 19in Eurorack to IEC 297-3 (DIN 1494 Pt.5)

Larger systems can be provided using multiple racks and interconnect cable.

### Mounting

Industry standard 19" racks with rear terminal access

### Assembly

All cards plug in to a standard pre-tested motherboard using DIN41612 connectors. This allows simple system expansion of system size at a later date.

### Connections

Plug and socket terminals of the rising clamp type, maximum wire size 12 AWG (2.5mm<sup>2</sup>). Quick disconnect terminals with locking screws available as an option.

Due to our policy of continuous product development, we reserve the right to amend specifications without notice.



RTK Instruments  
1531 Stuyvesant Avenue  
Union  
New Jersey 07083  
USA

Telephone: 908 688 6709  
Facsimile: 908 688 9040  
Email: sales@rtkinstruments.com  
Web: www.rtkinstruments.com