



INSTRUMENTS

**65-2494RK/65-2497RK
Oxygen Detector
Operator's Manual**

Part Number: 71-0179RK

Revision: 0

Released: 2/16/11

WARNING

Read and understand this instruction manual before operating detector. Improper use of the detector could result in bodily harm or death.

Periodic calibration and maintenance of the detector is essential for proper operation and correct readings. Please calibrate and maintain this detector regularly! Frequency of calibration depends upon the type of use you have and the sensor types. Typical calibration frequencies for most applications are between 3 and 6 months, but can be required more often or less often based on your usage.

Product Warranty

RKI Instruments, Inc. warrants gas alarm equipment sold by us to be free from defects in materials, workmanship, and performance for a period of one year from date of shipment from RKI Instruments, Inc. Any parts found defective within that period will be repaired or replaced, at our option, free of charge. This warranty does not apply to those items which by their nature are subject to deterioration or consumption in normal service, and which must be cleaned, repaired, or replaced on a routine basis. Examples of such items are:

- a) Absorbent cartridges
- b) Pump diaphragms and valves
- c) Fuses
- d) Batteries
- e) Filter elements

Warranty is voided by abuse including mechanical damage, alteration, rough handling, or repair procedures not in accordance with the operator's manual. This warranty indicates the full extent of our liability, and we are not responsible for removal or replacement costs, local repair costs, transportation costs, or contingent expenses incurred without our prior approval.

THIS WARRANTY IS EXPRESSLY IN LIEU OF ANY AND ALL OTHER WARRANTIES AND REPRESENTATIONS, EXPRESSED OR IMPLIED, AND ALL OTHER OBLIGATIONS OR LIABILITIES ON THE PART OF RKI INSTRUMENTS, INC. INCLUDING BUT NOT LIMITED TO, THE WARRANTY OF MERCHANTABILITY OR FITNESS FOR A PARTICULAR PURPOSE. IN NO EVENT SHALL RKI INSTRUMENTS, INC. BE LIABLE FOR INDIRECT, INCIDENTAL, OR CONSEQUENTIAL LOSS OR DAMAGE OF ANY KIND CONNECTED WITH THE USE OF ITS PRODUCTS OR FAILURE OF ITS PRODUCTS TO FUNCTION OR OPERATE PROPERLY.

This warranty covers instruments and parts sold to users by authorized distributors, dealers, and representatives as appointed by RKI Instruments, Inc.

We do not assume indemnification for any accident or damage caused by the operation of this gas monitor, and our warranty is limited to the replacement of parts or our complete goods.

Table of Contents

Overview	1
Specifications	1
Description	2
65-2494RK Oxygen Detector	2
Junction Box	3
Installation	3
Mounting the Oxygen Detector	3
Wiring the Oxygen Detector to a Controller	4
Startup	6
Introducing Incoming Power	6
Setting the Fresh Air Reading	6
Maintenance	6
Preventive Maintenance	6
Troubleshooting	8
Replacing Components of the Oxygen Detector	9
Calibration Frequency	10
Calibration	11
Preparing for Calibration	11
Setting the Fresh Air Reading	11
Setting the Zero Reading	11
Parts List	13

Overview

This manual describes the 65-2497RK oxygen detector. This manual also describes how to install, start up, maintain, and calibrate the oxygen detector when used with a gas monitoring controller. A parts list at the end of this manual lists replacement parts and accessories for the oxygen detector.

The 65-2497RK oxygen detector includes the 65-2494RK oxygen detector and a junction box. This manual may also be used for the 65-2494RK oxygen detector which does not include a junction box and is normally mounted in one of a controller's conduit hubs. If you are using a 65-2494RK oxygen detector, disregard all references to the junction box and junction box terminal strip.

Specifications

WARNING: *Do not use this product in a manner not specified in this instruction manual.*

Table 1 lists specifications for the 65-2494RK and 65-2497RK oxygen detectors.

Table 1: Specifications

Target Gas	Oxygen (O ₂)
Sampling Method	Diffusion
Detection Range	0-25% oxygen
Response Time	90% in 30 seconds
Accuracy	± 0.5% O ₂
Operating Temperature	-4°F to 113°F (-20°C to 45°C)

WARNING: *When using the 65-2494RK/65-2497RK, you must follow the instructions and warnings in this manual to assure proper and safe operation of the 65-2494RK/65-2497RK and to minimize the risk of personal injury. Be sure to maintain and periodically calibrate the 65-2494RK/65-2497RK as described in this manual.*

Description

This section describes the components of the 65-2494RK and 65-2497RK detectors. The 65-2497RK includes the 65-2494RK oxygen detector and a junction box. A two point terminal strip is provided inside the junction box for detector connections. The 65-2494RK does not include a junction box. Figure 1 below shows the components of the 65-2497RK.

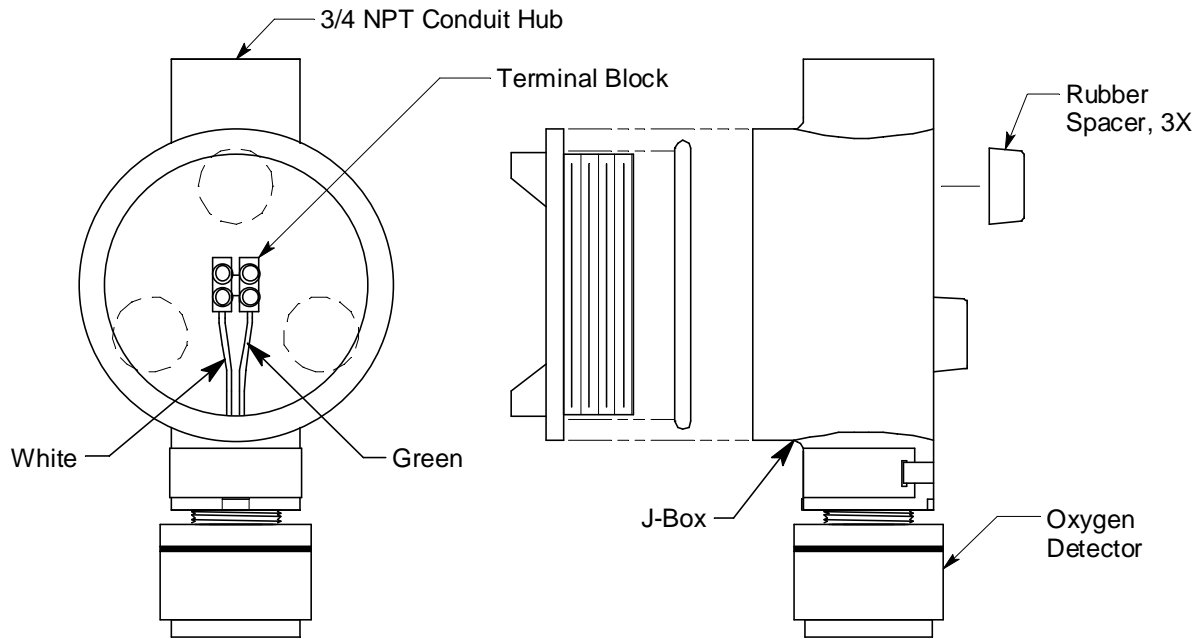

Figure 1: 65-2497RK Component Location

65-2494RK Oxygen Detector

The 65-2494RK oxygen detector consists of the detector housing body, detector housing cap, cap gasket, and the plug-in sensor.

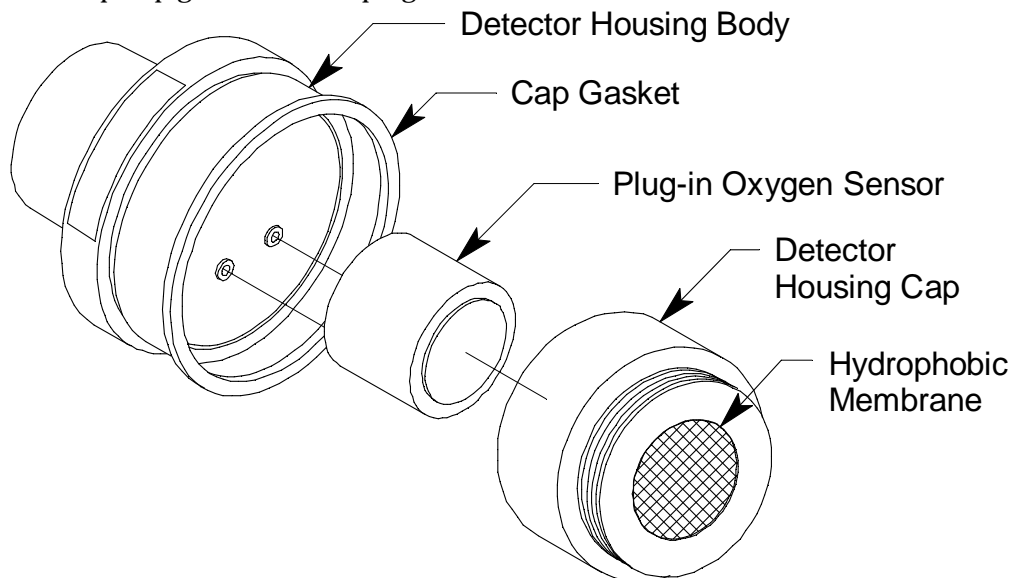

Figure 2: 65-2494RK Oxygen Detector Component Location

Detector Housing Body

The detector housing body protects the electronic components within the housing. Use the mounting threads at the top of the housing to screw the oxygen detector into a 3/4" NPT hub. Two wires extend from the top of the detector housing body. Use these wires to connect the detector to a controller. One of the wires is white and one of the wires is green.

The housing body includes two sockets installed on a circuit board. These sockets accept the plug-in sensor's two pins to provide an electrical connection for the sensor. The circuit board with the sockets conditions the sensor's signal before the signal reaches the controller.

Housing Cap & Cap Gasket

The housing cap screws onto the detector housing. It retains the plug-in sensor and protects it from damage. A foam gasket inside the housing cap seals against the face of the sensor when the cap is screwed on the housing body. A hydrophobic membrane on the outside of the cap face keeps water and particulates away from the sensor face behind the cap. Unscrew the detector cap to access the plug-in sensor for maintenance or replacement. A cap gasket seals the interface between the housing and cap.

Plug-in Sensor

The plug-in sensor is secured in the detector assembly by the housing cap. Through a series of chemical and electrical reactions, the sensor produces an electrical output that corresponds to the detection range of the detector. The sensing element used is a capillary type that is not susceptible to output changes with changes in atmospheric pressure.

Junction Box

Use the junction box to install the oxygen detector at a mounting site that is remote from a controller and to protect the detector wiring connections. Two conduit hubs allow you to mount the detector to the junction box and connect the wiring from the detector to a controller. Three spacers installed on the back of the junction box control the distance of the junction box from a mounting surface and ensure that there is enough room to install a calibration cup on the detector during calibration. A terminal block within the junction box facilitates the wiring connections. A cover on the front of the junction box allows access to the interior of the junction box.

Installation

This section describes procedures to mount the oxygen detector in the monitoring environment and wire the detector to a controller.

Mounting the Oxygen Detector

NOTE: If you are installing a 65-2494RK, it does not include a junction box and is usually factory installed in one of a controller's conduit hubs or may be field installed using the 3/4" NPT threads on the end with the wires. The 65-2497RK includes a junction box as shown in Figure 3 below.

1. Select a mounting site that is representative of the monitoring environment. Consider the following when you select the mounting site.
 - Select a site where the detector is not likely to be bumped or disturbed. Make sure there is sufficient room to perform start-up, maintenance, and calibration procedures.

- Select a site where the target gas is likely to be found first.

NOTE: If your application does not require a specific mounting site, mount the detector at approximately breathing level.

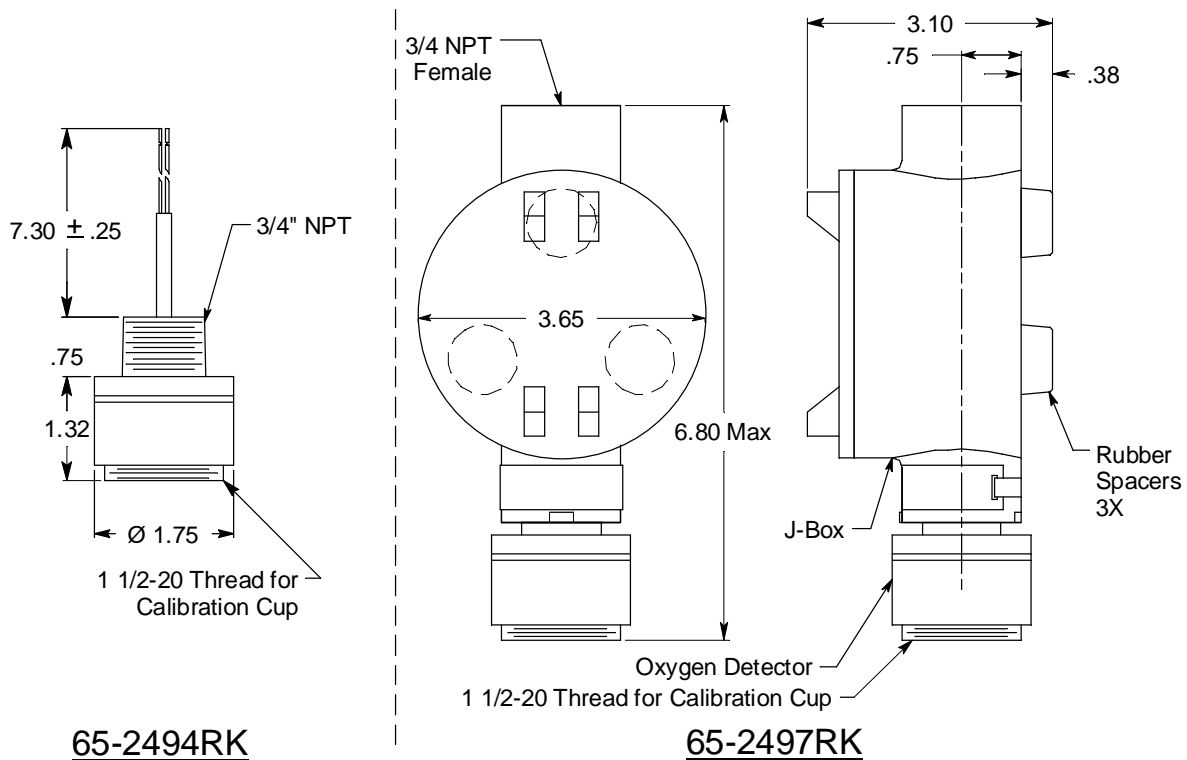

Figure 3: Outline & Mounting Dimensions, 65-2494RK & 65-2497RK

2. At the mounting site you select, hang or mount the junction box with the detector facing down (see Figure 3).

Wiring the Oxygen Detector to a Controller

WARNING: Always verify that power to the controller is OFF before you make wiring connections.

1. Turn off the controller.
2. Turn off or unplug power to the controller.
3. If the detector is mounted remotely from a controller using the junction box, proceed to step 4.

If the detector is mounted directly to a controller, it is normally factory wired. Confirm that the detector's white and green wires are connected to the appropriate controller detector terminals and skip to "Start Up" on page 6. See Figure 4, the controller operator's manual, and the controller's detector head specification sheet for the 65-2494RK detector for the wiring connections.

4. Remove the junction box cover.
5. Guide a two-conductor, shielded cable or two wires in conduit through the unused conduit hub of the junction box. Use appropriate conduit fittings and construction

technique for the environmental rating of the junction box. The junction box is rated NEMA 4X.

6. Connect the two wires to the detector using the terminal block.

CAUTION: *If using shielded cable, leave the drain wire insulated and disconnected at the detector. You will connect the opposite end of the cable's drain wire at the controller.*

7. Secure the junction box cover to the junction box.
8. Route the cable or wires leading from the oxygen detector through one of the conduit hubs at the controller housing. Use appropriate conduit fittings and construction technique for the environmental rating of the controller. RKI controllers are typically rated NEMA 4X.

CAUTION: *Do not route power and detector wiring through the same conduit hub. The power cable may disrupt the transmission of the detector signal to the controller.*

9. Connect the wires to the applicable controller terminal strip. See the controller operator's manual and the controller's detector head specification sheet for the 65-2497RK detector.

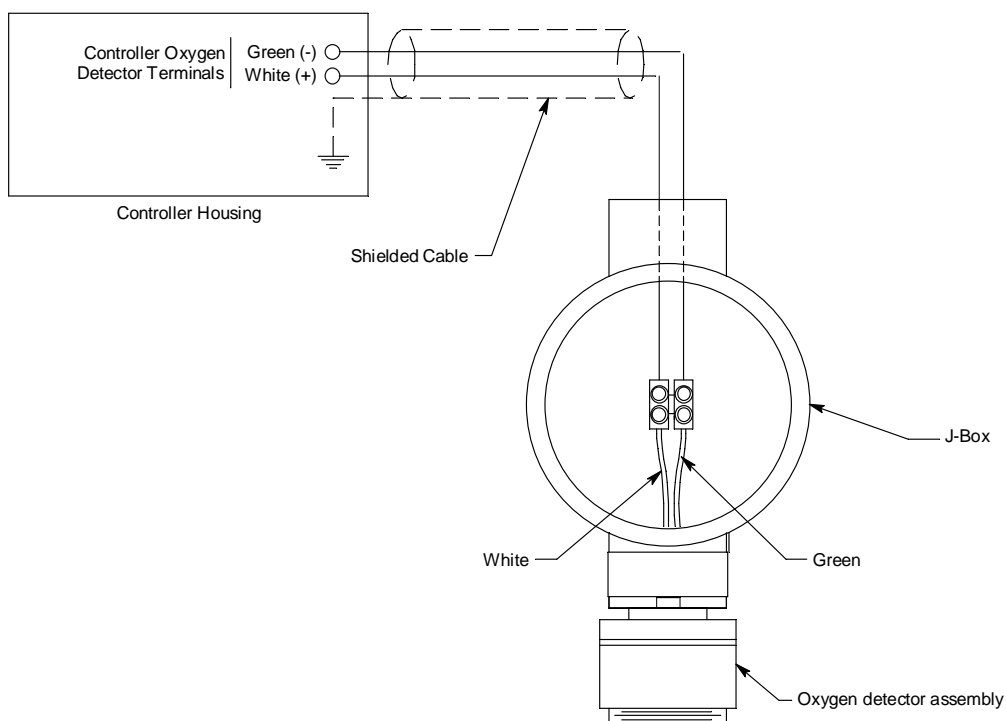

Figure 4: Wiring the Oxygen Detector to a Controller

10. If using shielded cable, connect the cable's drain wire to an available chassis ground at the controller. RKI controllers typically have a ground stud that is a convenient grounding location.

Start Up

This section describes procedures to start up the oxygen detector and place the detector into normal operation.

Introducing Incoming Power

1. Complete the installation procedures described earlier in this manual.
2. Verify that the power wiring to the controller is correct and secure. Refer to the controller operator's manual.
3. Turn on or plug in the incoming power, then turn on the controller.
4. Verify that the controller is on and operating properly. Refer to the controller operator's manual.

CAUTION: *Allow the detector to warm up for 5 minutes before you continue with the next section, "Setting the Fresh Air Reading".*

Setting the Fresh Air Reading

CAUTION: *If you suspect the monitoring environment is not a fresh air environment, use the zero air calibration cylinder to introduce "fresh air" to the detector and verify an accurate fresh air reading.*

1. Verify that the oxygen detector is in a fresh air environment (environment known to be free of toxic and combustible gases, and of normal oxygen content, 20.9%).
2. Verify a reading of 20.9% oxygen at the controller.
If the display reading is 20.9% oxygen, start up is complete. The oxygen detector is in normal operation. If the display reading is not 20.9% oxygen, continue with step 3.
3. Perform a fresh air adjustment operation at the controller. See the controller operator's manual for instructions.

Maintenance

This section describes maintenance procedures. It includes preventive maintenance, troubleshooting, and component replacement procedures.

Preventive Maintenance

This section describes a preventive maintenance schedule to ensure the optimum performance of the oxygen detector. It includes daily, monthly, and quarterly procedures.

Daily

Verify a display reading of 20.9% oxygen at the controller. Investigate significant changes in the display reading.

Monthly

This procedure describes a test to verify that the oxygen detector responds properly to oxygen deficiency.

WARNING: *The controller is not an active gas monitoring device during the response test procedure.*

NOTE: Performing a response test on the oxygen detector may cause alarms. Be sure to put the controller into its calibration program or disable external alarms before performing this test.

1. Place the controller into its calibration program or disable external alarms.
2. Verify that the controller display reading is 20.9% oxygen.
If the display reading is not 20.9% oxygen, set the fresh air reading, then continue this procedure. See the controller operator's manual for instructions to set the fresh air reading.
3. Exhale into the bottom of the oxygen detector housing.
4. Stop exhaling into the bottom of the detector, then verify that the reading on the controller display decreased from the normal reading of 20.9% oxygen.

NOTE: If the reading does not decrease, calibrate the detector as described in "Calibration" on page 11.

5. When the display reading rises above the decreasing alarm setpoint, return the controller to normal operation.

Quarterly

Calibrate the detector as described in "Calibration" on page 11. See the calibration frequency discussion in "Calibration Frequency" on page 10 to determine if a quarterly calibration schedule fits your needs.

Troubleshooting

The troubleshooting guide describes symptoms, probable causes, and recommended action for problems you may encounter with the oxygen detector.

NOTE: This troubleshooting guide describes detector problems only. See the controller operator's manual for problems you may encounter with the controller.

Table 2: Troubleshooting the Oxygen Detector

Condition	Symptom(s)	Probable Causes	Recommended Action
Fail Condition	<ul style="list-style-type: none"> Controller indicates a fail condition. 	<ul style="list-style-type: none"> The detector wiring is disconnected or misconnected. The plug-in sensor is not properly plugged into the socket pattern in the detector housing body. The detector's zero reading is low enough to cause a fail condition. The detector is malfunctioning. 	<ol style="list-style-type: none"> Verify that the detector wiring is correct and secure. Confirm that the plug-in sensor is installed properly. Perform a fresh air adjustment. A full calibration is recommended. If the fail condition continues, replace the plug-in sensor as described later in this section. If the fail condition continues, contact RKI for further instruction.
Slow or No Response/ Difficult or Unable to Calibrate	<ul style="list-style-type: none"> Detector responds slowly or does not respond to response test. Unable to accurately set the fresh air or zero reading during calibration. Detector requires frequent calibration. <p>Note: Under "normal" circumstances, the transmitter requires calibration once every 3 months.</p> <p>Some applications may require a more frequent calibration schedule.</p>	<ul style="list-style-type: none"> The calibration cylinder is low, out-dated, or defective. The calibration gas is not an appropriate concentration. The membrane on the detector housing cap is blocked with dirt or some other particulate contamination. The detector is malfunctioning. 	<ol style="list-style-type: none"> Verify that the calibration cylinder contains an adequate supply of a fresh test sample. Verify that the calibration gas concentration is appropriate for the transmitter. Zero emission air (20.9% oxygen) is normally used for a fresh air adjustment if the environment is suspect and 100% nitrogen (0% oxygen) is normally used for a zero adjustment. Check the sensor face for dirt. Clean if necessary. Check the face of the detector housing cap and remove any particulate contamination from the hydrophobic membrane if necessary. If the membrane appears saturated with contamination or damaged, replace the membrane as described in the next section. If the calibration/response difficulties continue, replace the plug-in sensor as described later in this section. If the calibration/response difficulties continue, contact RKI for further instruction.

Replacing Components of the Oxygen Detector

This section includes a procedure to replace the plug-in oxygen sensor, one to replace the hydrophobic membrane, and one to replace the entire oxygen detector assembly. In most cases, it is not necessary to replace the entire detector assembly.

Replacing the Plug-in Oxygen Sensor

CAUTION: *The plug-in sensor contains electrolyte which is an irritant. Do not disassemble the sensor when replacing it with a new one. If sensor electrolyte comes in contact with your skin, wash affected area thoroughly with soap and water.*

1. Turn off the controller.
2. Turn off or unplug power to the controller.
3. Unscrew the detector housing cap from the detector housing body.
4. Unplug and remove the old oxygen sensor.
5. Carefully plug the replacement sensor into the sockets located in the detector housing body.
6. Make sure the cap gasket is in place and screw the detector housing cap back onto the detector housing body.
7. Turn on power to the controller.
8. Turn on the controller and place into normal operation.

CAUTION: *Allow the replacement sensor to warm up for 5 minutes before you continue with the next step.*

9. Calibrate the detector as described in “Calibration” on page 11.

Replacing the Hydrophobic Membrane

1. Turn off the controller.
2. Turn off or unplug incoming power to the controller.
3. Unscrew the detector housing cap from the detector housing body.
4. Gently pry up the edge of the white hydrophobic membrane with a small flat blade screwdriver or a similar tool.
5. Peel off the hydrophobic membrane. It may be necessary to clean off the detector housing cap face to remove any residue left from the adhesive backed membrane.
6. Install the new membrane in the recess on the face of the detector housing cap.
7. Make sure the cap gasket is in place and screw the detector housing cap back onto the detector housing body.
8. Turn on the power to the controller.
9. Turn on the controller.

Replacing the Oxygen Detector

NOTE: In most cases, it is only necessary to replace the plug-in sensor.

1. Turn off the controller.
2. Turn off or unplug incoming power to the controller.
3. If the detector is installed directly on a controller, open the controller door.
If the detector is installed remotely from a controller in a junction box, remove the junction box cover.
4. If the detector is installed directly on a controller, disconnect the detector leads from the detector terminal strip in the controller. Note the position of the color-coded leads as you remove them.
If the detector is installed remotely from a controller in a junction box, disconnect the detector leads from the terminal block in the junction box. Note the position of the color-coded leads as you remove them.
5. Unscrew the detector from the controller conduit hub or junction box conduit hub.
6. Guide the detector leads of the replacement detector through the controller conduit hub or junction box conduit hub, then screw the mounting threads of the detector into the hub. If necessary for environmental conditions, apply thread sealant or teflon tape to the hub and/or detector threads to seal them.
7. If the detector is installed directly on a controller, connect the detector leads to the appropriate detector terminal strip terminals. See Figure 4 on page 5 for wiring to a generic controller. See the controller operator's manual and the controller's detector head specification sheet for the 65-2494RK detector for wiring specific to your controller.
If the detector is installed remotely from a controller in a junction box, connect the detector leads to the terminal block the same way the old detector was wired (see Figure 4 on page 5). See the controller operator's manual and the controller's detector head specification sheet for the 65-2497RK detector to verify the connections to the controller are correct.
8. If the detector is installed remotely from a controller in a junction box, reinstall the junction box cover.
9. Turn on or plug in power to the controller.
10. Turn on the controller and place into normal operation.

CAUTION: *Allow the replacement detector to warm up for 5 minutes before you continue with the next step.*

11. Calibrate the replacement detector as described in "Calibration" on page 11.

Calibration Frequency

Although there is no particular calibration frequency that is correct for all applications, a calibration frequency of every 3 months is adequate for most oxygen detector applications. Unless experience in a particular application dictates otherwise, RKI Instruments, Inc. recommends a calibration frequency of every 3 months for the oxygen detector.

If an application is not very demanding, for example detection in a clean, temperature controlled environment, and calibration adjustments are minimal at calibration, then a calibration frequency of every 6 months is adequate.

If an application is very demanding, for example if the environment is not well controlled, then more frequent calibration than every 3 months may be necessary.

Calibration

This section describes how to calibrate the oxygen detector. It includes procedures to prepare for calibration, set the fresh air reading, set the zero reading, and return to normal operation. It describes calibration using a calibration kit that includes a calibration cup, calibration gas, sample tubing, and a fixed flow regulator with an on/off knob. RKI Instruments, Inc. recommends using a 0.5 LPM (liters per minute) fixed flow regulator.

Preparing for Calibration

1. Screw the calibration cup onto the bottom of the oxygen detector.
2. Screw the regulator into the zero air calibration cylinder. Make sure the regulator is off. It is off when the on/off knob is turned all the way clockwise.
3. Use the sample tubing to connect the regulator to the calibration cup.

NOTE: If you can verify that the oxygen detector is in a fresh air environment, you do not need to apply zero air to the detector before adjusting the fresh air reading.

4. Put the controller into its calibration program. See the controller operator's manual for instructions to enter the calibration program.

Setting the Fresh Air Reading

1. Follow the instructions in the controller operator's manual for setting the fresh air reading.
2. When the instructions call for applying zero air to the detector, turn the regulator's on/off knob counterclockwise to open it. Gas will begin to flow.
3. Allow the gas to flow for two minutes.
4. Set the fresh air reading according to the controller operator's manual.
5. Turn the regulator's on/off knob clockwise to close it.
6. Unscrew the regulator from the zero air calibration cylinder. Leave the sample tubing connected to the regulator and the calibration cup.

NOTE: Depending on the size of your zero air cylinder, it is possible that you will have a different regulator for the zero air cylinder and the nitrogen gas cylinder. If necessary to fit the nitrogen gas cylinder, change the regulator.

Setting the Zero Reading

1. Screw the regulator into the 100% nitrogen calibration cylinder. Make sure the regulator is off. It is off when the on/off knob is turned all the way clockwise.
2. Follow the directions in the controller operator's manual for setting the zero reading.
3. When the directions call for exposing the detector to gas, turn the regulator's on/off knob counterclockwise to open it. Gas will begin to flow.

4. Allow the gas to flow to the detector for 2 minutes.
5. Set the zero reading according to the controller operator's manual.
6. After setting the zero reading, turn the regulator's on/off knob clockwise to turn it off.
7. Unscrew the regulator from the cylinder.
8. Unscrew the calibration cup from the oxygen detector. Make sure that you do not loosen the detector housing cap when you unscrew the calibration cup.

NOTE: For convenience, leave the regulator and calibration cup connected by the sample tubing.

9. Allow about 45 seconds for the gas reading to increase above the decreasing alarm point and then return the controller to normal operation.

NOTE: If you do not allow the gas reading to increase above the decreasing alarm point, then unwanted alarms may occur.

10. Verify that the controller display reading increases and stabilizes at 20.9% oxygen.
11. Store the components of the calibration kit in a safe and convenient place.

Parts List

Table 3 lists replacement parts and accessories for the oxygen detector.

Table 3: Parts List

Part Number	Description
06-1248RK-03	3 foot length of sample tubing for the calibration kit
07-0039RK	Detector housing cap gasket
18-0400RK-01	Junction box with rubber spacers
65-1025RK	Oxygen plug-in sensor
65-2494RK	Oxygen replacement detector assembly (includes sensor)
71-0179RK	<i>65-2494RK/65-2497RK Oxygen Detector Operator's Manual (this document)</i>
81-0076RK	Zero air calibration cylinder, 17 liter steel
81-0076RK-01	Zero air calibration cylinder, 34 liter steel
81-0076RK-03	Zero air calibration cylinder, 103 liter steel
81-0078RK	100% nitrogen calibration cylinder, 17 liter steel
81-0078RK-01	100% nitrogen calibration cylinder, 34 liter steel
81-0078RK-03	100% nitrogen calibration cylinder, 103 liter steel
81-F301RK	Calibration kit for oxygen detector head, 103 liter
81-F301RK-LV	Calibration kit for oxygen detector head, 34 liter
81-1050RK	Regulator with gauge and knob, 0.5 LPM, for 17 liter and 34 liter steel calibration cylinders
81-1051RK	Regulator with gauge and knob, 0.5 LPM, for 34AL/58/103 liter calibration cylinders
81-1117RK	Calibration cup