

# **PT-400**

# **User Manual**

# Table of Contents

<b>Introduction .....</b>	<b>iii</b>
<b>Warranty and Warranty Restrictions .....</b>	<b>iv</b>
<b>Chapter 1: Dimensions and Specifications .....</b>	<b>1</b>
Dimensions .....	1
Specifications .....	2
Electrical Connectors and Pinout Table .....	3
<b>Chapter 2: Installation and Removal Procedures and Notes .....</b>	<b>4</b>
Tools Needed .....	4
Mounting Instructions .....	4
Electrical Installation .....	4
Removal Instructions .....	4
<b>Chapter 3: Maintenance .....</b>	<b>5</b>
General Care .....	5
Zero Trimming .....	5
Re-Calibration .....	6
Repair and Returns .....	6
<b>Chapter 4: Hazardous Location Installation and Certification .....</b>	<b>7</b>
Intrinsically Safe Wiring Diagram .....	7
Non-Incendive Wiring Diagrams .....	8-10

# Introduction

Thank you for purchasing a PT-400 series pressure transmitter from BinMaster. We appreciate your business! Please take a few minutes to familiarize yourself with your PT-400 and this manual.

The PT-400 series of pressure transmitters offers reliability over a wide range of pressures and in harsh industrial conditions and hazardous locations. It is certified intrinsically safe for hazardous areas in the US, Canada, Europe and internationally by CSA, ATEX, and IECEx for Class 1, Zone 0 environments. The small size, integrated electronics, wide operating temperature range, and durability, make the PT-400 the perfect instrument for static and dynamic pressure measurements with an amplified output signal.

## Reading your label

The PT-400 comes with a label that includes the its model number, part number, serial number, and a wiring pinout table. Please ensure that the part number and pinout table on your label match your order. The following electrical ratings and approvals are also listed on the label. Please request the Certificate of Compliance and Declaration of Conformity for further details.

## Electrical ratings



Input: 9 to 28 Volts DC; Outputs: 4-20mA / 0-5VDC / 0-10VDC (per order)  
Exia Class I Division 2; Groups C, D T4  
Class I, Zone 2, Group IIB  
AEx nC IIB T4: Ta: -40°C to 85°C  
Ex nL IIB T4: Ta: -40°C to 85°C  
Maximum Working Pressure: 10,000 PSI

### PT-400-L1 (4-20mA)

$V_{max} U_i = 28VDC$ ,  $I_{max} I_i = 110mA$ ,  $P_{max} P_i = 0.77W$ ,  $C_i = 0.055\mu F$ ,  $L_i = 7.95\mu H$   
Install in accordance with drawing 9002794, sheet 2 (page 9).

### PT-400-L3/L10 (0-5V/0-10V)

$V_{max} U_i = 28VDC$ ,  $I_{max} I_i = 110mA$ ,  $P_{max} P_i = 0.77W$ ,  $C_i = 0\mu F$ ,  $L_i = 0\mu H$   
Install in accordance with drawing 9002794, sheets 3 & 4 (page 10 & 11).



Input: 9 to 28 Volts DC; Output: 4-20mA (per order)  
Exia Class I Division 1; Groups C, D T4  
Class I, Zone 0, Group IIB  
AEx ia IIB T4: Ta: -40°C to 85°C  
Ex ia IIB T4: Ta: -40°C to 85°C  
Maximum Working Pressure: 10,000 PSI

$V_{max} U_i = 28VDC$ ,  $I_{max} I_i = 110mA$ ,  $P_{max} P_i = 0.77W$ ,  $C_i = 0.055\mu F$ ,  $L_i = 7.95\mu H$   
Install in accordance with drawing 9002794, sheet 1 (page 8).

**i** IMPORTANT: Your PT-400 MUST be installed according to drawing 9002794 (Intrinsically Safe Wiring Diagram or Non-Incendive Wiring Diagrams) as indicated above to meet listed approvals. Faulty installation will invalidate all safety approvals and ratings.

## The following approvals only apply to the L1 (4-20mA) version

ATEX Directive:  0344

Sira 12ATEX2294



II 1G Ex ia IIB T4 Ga

Ta: -40°C to 85°C

$U_i \leq 30V$ ,  $I_i \leq 110mA$ ,  $P_i \leq 1 W$ ,  $C_i \leq 0.055\mu F$ ,  $L_i \leq 7.95\mu H$

IECEX CSA 12.0018

Ex ia IIB T4 Ga

## Warranty and Warranty Restrictions

BinMaster warrants this product against defects in material and workmanship for two (2) years according to the following terms;

- 1.) This warranty extends to the original purchaser only and commences on the date of original purchase.
- 2.) BinMaster's sole obligation under said warranty is to repair, or at its option replace the defective parts. The buyer shall have no other remedy. All special, incidental and consequential damages are excluded. The buyer must deliver the product under warranty prepaid to the factory. BinMaster's obligation is limited to the cost of material and labor to repair or replace, and does not include transportation expenses.
- 3.) This warranty shall be voided, in our sole judgment, by alterations of equipment except by BinMaster, or tampering with, improper installation or maintenance, accident or misuse, or act of God. This warranty expressly excludes all damage to the product resulting from careless or neglectful packaging or transportation. The warranty does not extend to repairs made necessary by normal wear.
- 4.) This warranty is in lieu of all other warranties, expressed or implied including any implied warranties or merchantability or fitness for particular purpose. No employee, agent, franchise dealer or other person is authorized to give any warranties of any nature on behalf of BinMaster.
- 5) BinMaster shall in no event be responsible for any warranty work done without first obtaining BinMaster's written consent.
- 6) Except as provided herein, BinMaster shall have no liability, loss or damage caused or alleged to be caused directly or indirectly by this equipment.
- 7) This warranty gives the buyer specific legal rights, and you may also have other rights which vary from state to state.
- 8) For service, please call 402-434-9102.

# Chapter 1: Specifications and Options

- Dimensions

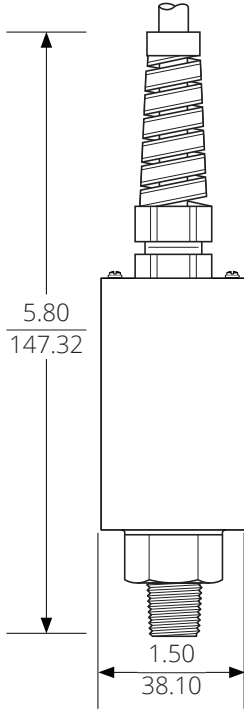

PT-400 with Pigtail and NPTM

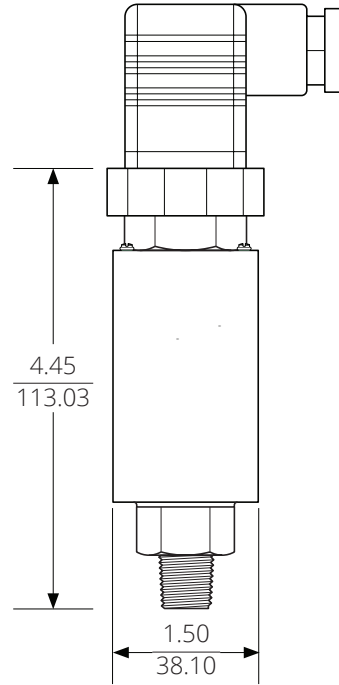

PT-400 with DIN 43650 and L-Bracket and NPTM

Total length of PT-400 with DIN 43650 and L-Bracket is equal to total length of PT-400 with Pigtail.

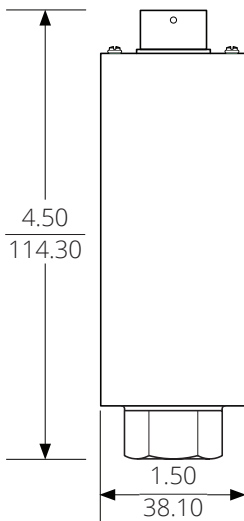

PT-400 with 4 or 6 pin Bayonet on Extended Can and NPTF

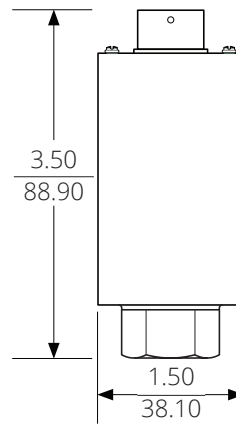

PT-400 with 4 or 6 pin Bayonet and NPTF

## • Specifications

### Performance

Pressure Ranges	0 to 30K PSIS
Analog Output	4-20mA, 0-5VDC, 0-10VDC
Over Pressure	2X Full Scale or limit of fitting, whichever is less
Burst Pressure	3.0X Full Scale or limit of fitting, whichever is less

### Accuracy

Linearity, Hystereses & Repeatability	±0.25% of Full Scale (BFSL) (1% for pressure ≤ 1 psi)
Thermal Zero Shift	[±0.036% FSO/°C      (±0.02% FSO/°F)]
Thermal Span Shift	[±0.036% FSO/°C      (±0.02% FSO/°F)]

### Environmental

Operating Temperature	-40 to 85°C	(-40 to 185°F)
Compensated Temperature	-17 to 54°C	(0 to 130°F)
Enclosure Protection	IP67	

### Electrical

Supply Voltage (at sensor)	4-20 mA:	9-28 VDC
	0 to 5 VDC:	9-28 VDC
	0 to 10 VDC:	12.5-28 VDC
Output Signal @ 21°C	4-20 mA:	3-30 mA max.
	0 to 5 VDC:	7mA max
	0 to 10 VDC:	14mA max

### Masterials of Construction



Wetted Materials	316L Stainless Steel ( ≤ 1,000 psi) 17-4 Stainless Steel ( > 1,000 psi) Incoloy (10,000 - 30,000 psi)
Enclosure	316L Stainless Steel

### Mechanical

Pressure Connection	Contact factory for complete list
Weight	283g (10 oz.)

• **Electrical Connectors, Pinout Table, and Supply Power Table**

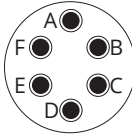
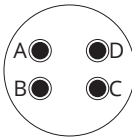
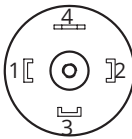
PT-400 Series Pin Out Table

		<b>4-20 mA</b>	<b>0-5 VDC</b>	<b>0-10 VDC</b>		
6 Pin Bayonet	A	+ Excitation	+ Excitation	+ Excitation		6 Pin Bayonet Connector
	B	- Excitation	+ Output	+ Output		
	C	N/C	- Output	- Output		
	D	N/C	- Excitation	- Excitation		
	E	N/C	N/C	N/C		
	F	N/C	N/C	N/C		
4 Pin Bayonet	A	+ Excitation	+ Excitation	+ Excitation		4 Pin Bayonet Connector
	B	- Excitation	+ Output	+ Output		
	C	N/C	- Output	- Output		
	D	N/C	- Excitation	- Excitation		
4 Pin DIN	1	+ Excitation	+ Excitation	+ Excitation		4 Pin DIN Connec- tor
	2	- Excitation	+ Output	+ Output		
	3	N/C	- Output	- Output		
	4	Case Ground	- Excitation	- Excitation		
4 Pin M12	1	+ Excitation	+ Excitation	+ Excitation		4 Pin M12 Micro Connector
	2	- Excitation	+ Output	+ Output		
	3	N/C	- Output	- Output		
	4	N/C	- Excitation	- Excitation		
Pigtail	Red	+ Excitation	+ Excitation	+ Excitation		
	Grn	N/C	+ Output	+ Output		
	Wht	N/C	- Output	- Output		
	Blk	- Excitation	- Excitation	- Excitation		
	Shld	Gnd	Gnd	Gnd		

N/C indicates no connection  
For alternate pinouts, please consult factory

PT-400 Series Supply Power Table

	<b>4-20 mA</b>	<b>0-5 VDC</b>	<b>0-10 VDC</b>
Power Supply	9-28 VDC	9-28 VDC	12.5-28 VDC

# Chapter 2: Installation and Removal Procedures and Notes

- **Tools Needed**

- Wrench sized appropriately for your PT-400's process connection.
- Thread tape or sealant compound for threaded connections.

- **Mounting Instructions**

Mounting your pressure transducer is easy if you follow a few simple steps:

- Never over-tighten the sensor. This can compress the diaphragm, changing how it reacts to pressure. In all cases, tighten the sensor as little as possible to create an adequate seal. On straight threads, tighten only until you feel the o-ring compress - making sure you don't damage or extrude the o-ring.
- Always use thread tape or sealant compound on tapered threads. Wrap thread tape in the opposite direction of the threads so it does not unravel as you screw the sensor into place. Unraveling can cause uneven distribution and seal failure. For straight threads use an o-ring.
- Always start screwing in your sensor by hand to avoid cross-threading. Thread failure can be a problem if you damage threads by over-tightening them or by crossing threads.

- **Electrical Installation**

- Check the pinout table on your PT-400 against your order.
- Check that your electrical system wiring matches the pinout table on your PT-400.
- For instruments with connectors, make the connection. Otherwise, attach your wires to the provided terminal strip.

- **Removal Instructions**

Removing your PT-400 from service must be done with care. It's easy to create an unsafe situation, or damage your sensor, if you are not careful to follow these guidelines:

- Make sure the pressure is completely removed from the line or vessel where your sensor is installed. Follow any and all procedures for safely isolating any media contained inside the line or vessel.
- Remove the sensor with an appropriately sized wrench (per your process connection).
- Clean the sensor's fitting and diaphragm of any debris (see General Care) and inspect for damage.
- Store your sensor in a dry place, at a temperature between -40° F and 180° F.

 **DANGER:** Removing your PT-400 Pressure Transmitter while there is still pressure in the line could result in injury or death.



# Chapter 3: Maintenance

## • General Care

Your PT-400 series pressure transmitter is very low maintenance and will need little care as long as it is installed correctly. However, in general, you should:

- Keep the transmitter and the area around it generally clean.
- Avoid applications for which the transmitter was not designed, such as extreme temperatures, contact with incompatible corrosive chemicals, or other damaging environments.
- Inspect the threads whenever you remove the transmitter from duty or change its location.
- Avoid touching the diaphragm. Contact with the diaphragm, especially with a tool, could permanently shift the output and ruin accuracy.
- Clean the diaphragm or the diaphragm bore with extreme care. If using a tool is required, make sure it does not touch the diaphragm.

## • Zero Trimming

- Remove the protective screw.
- Ensure that the transmitter is at 0 psig or 0 psia (vacuum if absolute). For compound ranges, i.e., -15 psi to 30 psi, the 4 mA or 0 V set point is also at vacuum.
- Using a jeweler's screwdriver or a suitable instrument, adjust the "Z" pot until you have a 4 mA (4-20 mA) or 0 V (5 VDC, 10 VDC) output.

**i** IMPORTANT: Do not make changes to the Span adjustment (the "S" pot to the right, see Figure 3.1) as part of the zero trimming. The Span should only be changed as part of the recalibration of a gauge with a known pressure source.

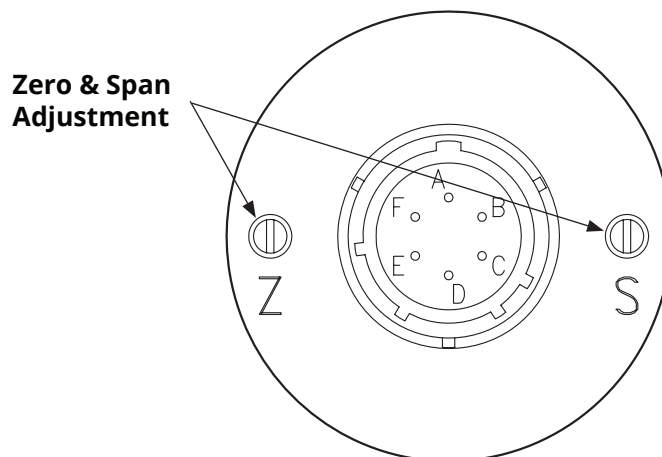

Figure 3.1

- **Re-Calibration**

This procedure requires a known pressure source of at least  $\pm 0.1\%$  accuracy in order to fully utilize the accuracy potential of the PT-400. (If not available, you can return it to the factory for re-calibration.)

- Ensure that the transducer is at 0 psig or 0 psia (vacuum if absolute), and adjust zero as per instructions for zero trimming.
- Apply full scale pressure to the pressure port and adjust the Span ("S") pot (on the right of Figure 3.1) until the full scale signal is reached.
- Re-check zero and re-adjust the zero ("Z") pot if required
- Repeat previous two steps until no further adjustment is required.

 NOTE: You may also return the PT-400 to the factory for repair and/or adjustment.

- **Repair and Returns**

Should your PT-400 series pressure transmitter require service, please contact the factory. We will issue you a Return Material Authorization (RMA) number with instructions.

- Phone: 402-434-9102
- Email: [info@binmaster.com](mailto:info@binmaster.com)

Please have your PT-400's part number and serial number available. See Warranty and Warranty Restrictions for more information.

# Chapter 4: Hazardous Location Installation and Certification

## • Intrinsically Safe Wiring Diagram (4-20mA Output)

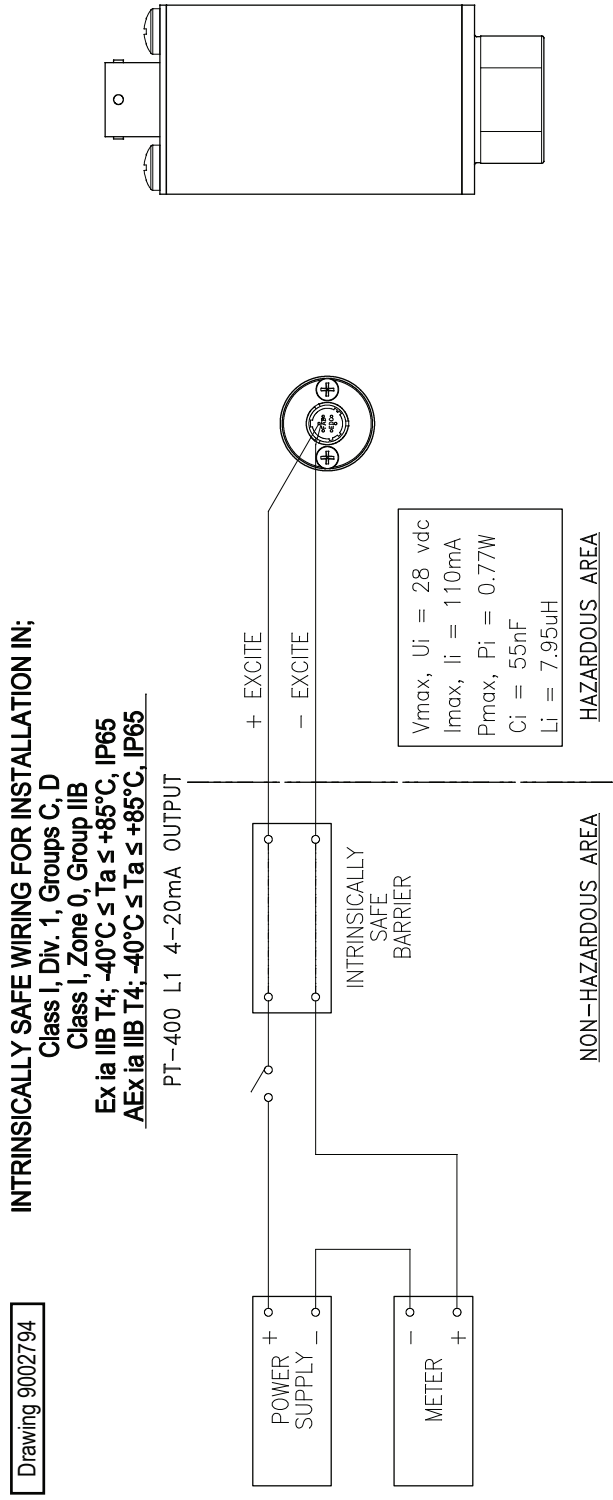

ACTUAL PINOUT PER LABEL ON UNIT

\* WARNING: SUBSTITUTION OF COMPONENTS MAY IMPAIR INTRINSIC SAFETY

1. Barriers must be NRTL approved and must be installed in accordance with manufacturer's instructions.
2. Barrier parameters must meet the following requirements:  
 $V_{oc}/U_o \leq V_{max}/U_i$        $C_a/C_o \geq C_i + C_{cable}$   
 $I_{sc}/I_o \leq I_{max}/I_i$        $L_a/L_o \geq L_i + L_{cable}$   
 $P_o \leq P_i$
3. Maximum non-hazardous area voltage must not exceed 250 V.
4. Install in accordance with the NEC (ANSI/NFPA 70) and ANSI/ISA RP12.6 (U.S. Locations) or Canadian Electrical Code, Part 1 (Canadian Locations).

Drawing 9002794

• **Non-Incendive Wiring Diagram (4-20mA Output)**

Drawing 9002794

**NONINCENDIVE WIRING FOR INSTALLATION IN :**

Class I, Division 2, Groups C and D  
 Class I, Zone 2, Group IIB  
 Ex nL IIB T4;  $-40^{\circ}\text{C} \leq T_a \leq +85^{\circ}\text{C}$   
 AEx nC IIB T4;  $-40^{\circ}\text{C} \leq T_a \leq +85^{\circ}\text{C}$   
 PT-400 L1 4-20mA OUTPUT

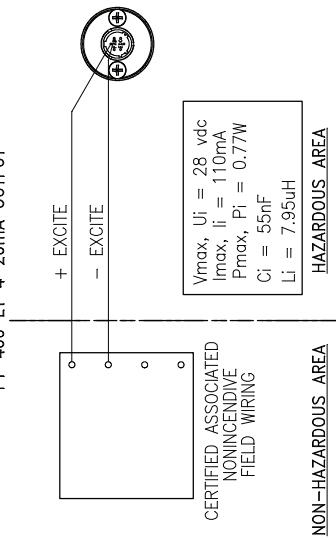

1. These devices must be connected to a suitably certified and approved apparatus that provides non-incendive outputs either equal to or less than those as indicated by the applicable control drawings. This certified apparatus must be located in a safe area.
2. This certified apparatus must be located in a safe area.
3. Maximum non-hazardous area voltage must not exceed 250 V
4. Install in accordance with the NEC (ANSI/NFPA 70) and ANSI/ISA RP12.6 (U.S. Locations) or Canadian Electrical Code, Part I (Canadian Locations).



ACTUAL PINOUT PER LABEL ON UNIT

\* WARNING: SUBSTITUTION OF COMPONENTS MAY IMPAIR INTRINSIC SAFETY

• **Non-Incendive Wiring Diagram (0-5VDC Output)**

Drawing 9002794

**NONINCENDIVE WIRING FOR INSTALLATION IN :**

Class I, Division 2, Groups C and D

Class I, Zone 2, Group IIB

Ex nL IIB T4;  $-40^{\circ}\text{C} \leq \text{Ta} \leq +85^{\circ}\text{C}$

AEx nC IIB T4;  $-40^{\circ}\text{C} \leq \text{Ta} \leq +85^{\circ}\text{C}$

PT-400 L3 0-5VDC VOLTAGE OUTPUT

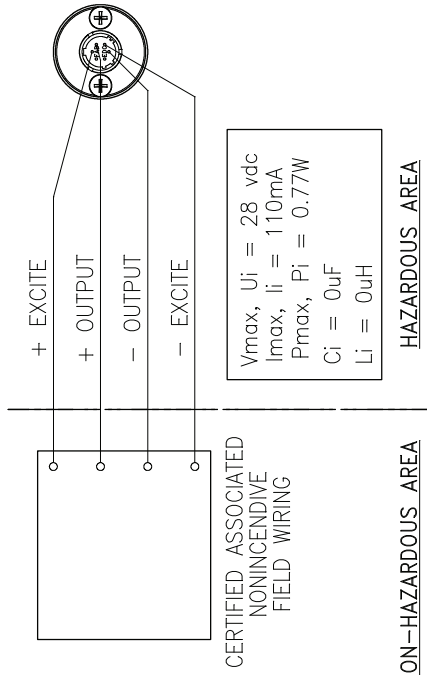

1. These devices must be connected to a suitably certified and approved apparatus that provides non-incendive outputs either equal to or less than those as indicated by the applicable control drawings. This certified apparatus must be located in a safe area.

2. This certified apparatus must be located in a safe area.

3. Maximum non-hazardous area voltage must not exceed 250 V

4. Install in accordance with the NEC (ANSI/NFPA 70) and ANSI/ISA RP12.6 (U.S. Locations) or Canadian Electrical Code, Part 1 (Canadian Locations).

ACTUAL PINOUT PER LABEL ON UNIT

\* WARNING: SUBSTITUTION OF COMPONENTS MAY IMPAIR INTRINSIC SAFETY

• **Non-Incendive Wiring Diagram (0-10VDC Output)**

Drawing 9002794

**NONINCENDIVE WIRING FOR INSTALLATION IN ;**

Class I, Division 2, Groups C and D

Class I, Zone 2, Group IIB

Ex nL IIB T4;  $-40^{\circ}\text{C} \leq \text{Ta} \leq +85^{\circ}\text{C}$

**AEx nC IIB T4;  $-40^{\circ}\text{C} \leq \text{Ta} \leq +85^{\circ}\text{C}$**

PT-400 L10 0-10VDC VOLTAGE OUTPUT

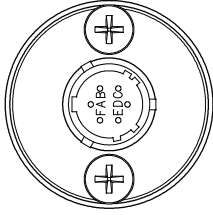
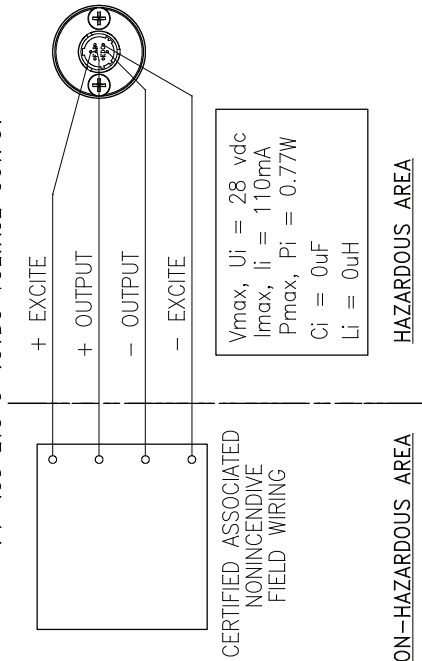

1. These devices must be connected to a suitably certified and approved apparatus that provides non-incendive outputs either equal to or less than those as indicated by the applicable control drawings. This certified apparatus must be located in a safe area.
2. This certified apparatus must be located in a safe area.
3. Maximum non-hazardous area voltage must not exceed 250 V
4. Install in accordance with the NEC (ANSI/NFPA 70) and ANSI/ISA RP12.6 (U.S. Locations) or Canadian Electrical Code, Part I (Canadian Locations).

ACTUAL PINOUT PER LABEL ON UNIT

\* WARNING: SUBSTITUTION OF COMPONENTS MAY IMPAIR INTRINSIC SAFETY



