



RHM12

Standard 1 inch Coriolis Mass Flow Meter

Features

- Standard pressure ratings up to 790 bar (11458 psi)
- Temperature ratings from -196 to 350°C (-320 to 662°F)
- Mass flow uncertainty down to 0.12%
- Density uncertainty down to 0.5%
- Repeatability better than 0.05%
- Typical measuring ranges between 1 and 100 kg/min
- Accurately measure low flow rates down to 750 g/min
- Unique robust torsion driven oscillation system
- Process connection customization available
- Minimum pipe footprint versions available
- Approved for use in hazardous areas
- Stainless steel case
- Removable connection manifold version available for easy and efficient maintenance
- Remote and compact transmitter versions available

Applications

Typical applications include:

- General Flow Control
- Additive Dosing
- Mixing
- Batching
- Package and Container Filling

Benefits

- Torsion oscillator design assures a stable and drift free measurement with excellent signal to noise ratios
- Resilient to external noise and vibration
- Insensitive to pipe pressure changes
- Robust tube wall thickness provides increased operational safety in abrasive applications
- Corrosion resistant
- Long sensor life guaranteed due to low mechanical stresses in the meter mechanism
- No moving parts to wear or fail

RHM12 General Specifications

Nominal Max Flow Range:	Parallel/dual path measurement tube versions: 100 kg/min (220.5 lb/min) Serial/single path measurement tube versions: 50 kg/min (110.2 lb/min)
Density Range:	5 to 5000 kg/m ³ (0.31 to 312 lb/ft ³)
Temperature Range:	5 temperature range options cover temperatures from -196°C to 350°C (-320°F to 662°F)
Pressure Ratings:	Dependent upon material
Electrical Connection:	Cable entry M25 x 1.5 (standard) M20 x 1.5, ½" NPT, ¾" NPT (optional) Max cable length to RHE remote transmitter 100m (330 ft)
Sensor Housing Materials:	1.4301 / 304 stainless steel (standard), 1.4571 / 316Ti stainless steel (optional) Epoxy coated aluminium electrical box (standard), 1.4571 / 316Ti stainless steel (optional)
Enclosure Type:	Protection class IP 65. Optional IP 66 / NEMA 4X
Material of Wetted Parts:	Sensors are available in a variety of standard and custom materials to suit a wide range of pressure ratings and chemical compatibility requirements. See the pressure ratings listing in this document for further details
Finishes:	ANSI flange finish: AARH 125 to 250 µin, Ra 3.2 to 6.3 µm
Certifications and Approvals:	ATEX approval Zone 0: Ex II 1 G Ex ia IIC T1-T6 Ga ATEX rating Zone 2: Ex II 3 G Ex nA IIC T1-T6 Gc CSA USA-Canada, Class I, Div. 1, Groups A, B, C, D PED according to 97/23/EC Art.3 (3) Sound Engineering Practice (SEP) or Module A1
Documentation:	All sensors are supplied with a traceable calibration certificate. Optional documentation items available: - Traceable material certificates - Certificates of origin and conformity - Welding - NACE - Quality - Production and manufacturing procedures Other documentation to client requirements available
Proof Testing:	Hydrotest, dye penetrant, x-ray, PMI
Options:	Enclosure heating matrix for high temperature applications

Transmitter Range

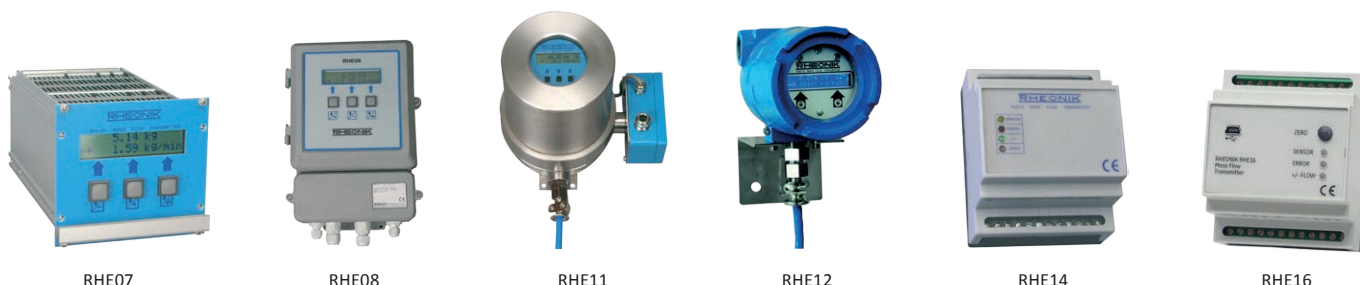

Any Rheonik Mass Flow Transmitter model can be combined with an RHM12 sensor to provide an overall mass flow measurement system to suit any requirement. Rheonik Coriolis transmitters are designed for process, industrial and OEM applications. Together they offer a tremendous range of options for system designers and end users alike.

RHM12 Measurement Performance

Standard Calibration		
Flow Rate		Uncertainty
kg/min	lb/min	in % of reading
100	220	0.20
40	88	0.20
10	22	0.20
5.0	11	0.20
2.0	4.4	0.50

Goldline Calibration*		
Flow Rate		Uncertainty
kg/min	lb/min	in % of reading
75	165	0.10
40	88	0.10
10	22	0.10
7.50	17	0.10
3.75	8.3	0.12

Low Flow Calibration*		
Flow Rate		Uncertainty
kg/min	lb/min	in % of reading
40	88	0.20
20	44	0.20
10	22	0.20
2.0	4.4	0.20
1.5	3.3	0.60

*Goldline and Low Flow Calibration is not available with all configurations of the RHM12. Please check with factory.

Mass Flow Calibration Options	
A	50:1 Standard Calibration – 0.5% Uncertainty between 100 and 2 kg/min
B	20:1 Standard Calibration – 0.2% Uncertainty between 100 and 5 kg/min
C	1:20 Calibration – 0.2% Uncertainty between 2 and 40 kg/min
G	20:1 Goldline Calibration – 0.15% Uncertainty between 75 and 3.75 kg/min
P	10:1 Goldline Calibration – 0.12% Uncertainty between 75 and 7.5 kg/min
1	Low Flow Calibration – 0.2% Uncertainty between 2 and 40 kg/min, 0.6% between 1.5 and 2 kg/min

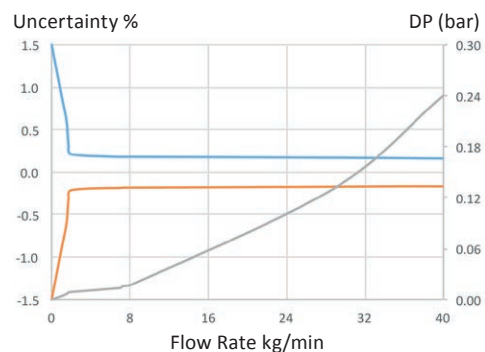
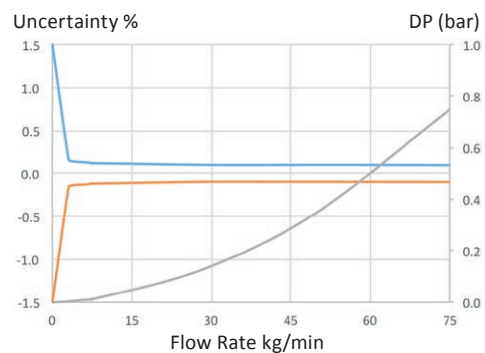
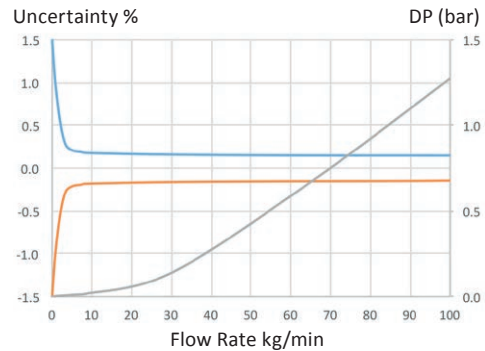

- *Uncertainty of reading (incl. zero drift) stated at reference condition of: H₂O, 18-24°C (66-76°F), 1-3 bar (15-45 psi) when installed according to field manual*
- *Pressure drop indications are based upon H₂O flowing in a meter with P1 pressure rating and PM0 (parallel measuring tubes with manifold block) construction*
- *Serial path versions offer the same accuracy performance at half the flow (Nominal max. flow range of serial versions = 50 kg/min). Pressure drop will be greater*
- *For customized calibration range or uncertainty levels, please consult factory*

Flow Measurement Repeatability

Standard ± 0.1% of rate
Goldline ± 0.05% of rate

Density Measurement Performance (liquids)

Standard 2 point calibration ±1% of value
Optional 3 point calibration ±0.5% of value
Gas density – depends upon pressure

Temperature

Better than ± 1°C

RHM12 Pressure Ratings

The maximum pressure (P_{max}) of a sensor is determined by its lowest rated part. The lowest rated part can be either the measuring tube (P_{max} indicated below), the construction type (P_{max} indicated in the Part Number Code section, last page) or the process connection (for P_{max} see published standards or manufacturer information).

RHM12 Measurement Tube Pressure Ratings

Pressure Code	Material Code	Material	P_{max}				
			bar	psi	@	°C	°F
P1 (std.)	M1 (std.)	1.4571 (316Ti) UNS S31635	212	3075	@	50	122
			190	2756	@	120	248
			164	2379	@	210	410
			138	2002	@	350	662
P1	M3	2.4602 (Alloy C22) UNS N06022	292	4235	@	50	122
			258	3742	@	120	248
			220	3191	@	210	410
			184	2669	@	350	662
P1	M4*	Tantalum UNS R05200	110	1595	@	50	122
			84	1218	@	120	248
			69	1001	@	210	410
P1	10**	1.4410 (Super Duplex) UNS S32750	507	7353	@	50	122
			444	6440	@	120	248
			402	5831	@	210	410
P1	62**	1.4462 (Duplex) UNS S31803	405	5874	@	50	122
			354	5134	@	120	248
			310	4496	@	210	410
P2	M1 (std.)	1.4571 (316Ti) UNS S31635	331	4801	@	50	122
			296	4293	@	120	248
			255	3698	@	210	410
			215	3118	@	350	662
P2	M3	2.4602 (Alloy C22) UNS N06022	456	6612	@	50	122
			403	5844	@	120	248
			344	4988	@	210	410
			287	4162	@	350	662
P2	10**	1.4410 (Super Duplex) UNS S32750	790	11458	@	50	122
			693	10051	@	120	248
			626	9079	@	210	410
P2	62**	1.4462 (Duplex) UNS S31803	631	9152	@	50	122
			553	8021	@	120	248
			484	7020	@	210	410

*Only with T1, TA, T2 temperature range (note max. operating temp. is 150°C) and PF0 construction type only (max. ANSI 300/PN40).

**Only with T1, TA, T2 temperature range (note min. temp. is -40°C) and PF0 construction type.

Other Materials

Additional/custom wetted materials (Inconel, Monel, 304 stainless steel, others) may be possible for chemical compatibility, lower pressure drop, abrasion allowance, other application specific requirements.

Contact factory with specification for assessment and availability.

RHM12 Mechanical Construction

PM0/SM0: Serial or parallel measuring tubes with flange connection and removable manifold with PTFE seals

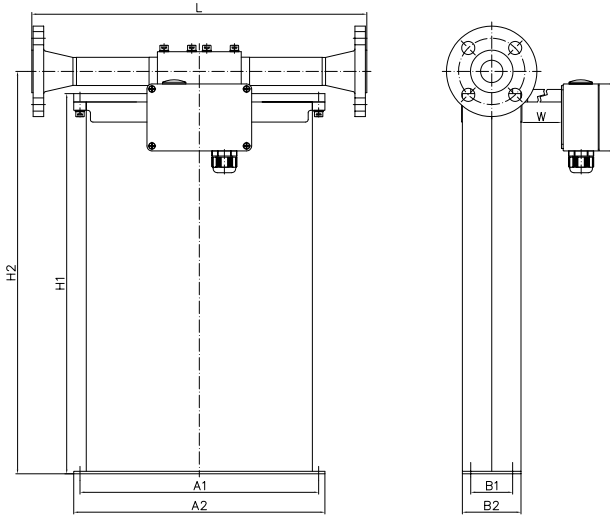

Process Connection	Face to face length (L)		Order Code
	mm	in	
ANSI 1" 150# RF	400	15.75	A1
ANSI 1" 300# RF	400	15.75	A2
ANSI 1" 600# RF	400	15.75	A3
ANSI 1" 1500# RF	450	17.72	A6
ANSI 1" 1500# RTJ	450	17.72	R1
DIN DN25/PN16	400	15.75	D4
DIN DN25/PN40	400	15.75	D1
DIN DN25/PN100	400	15.75	D2
JIS RF 10k 25A (1")	400	15.75	J1
JIS RF 20k 25A (1")	400	15.75	J2

PM0/SM0: Serial or parallel measuring tubes with female thread connection and removable manifold with PTFE seals

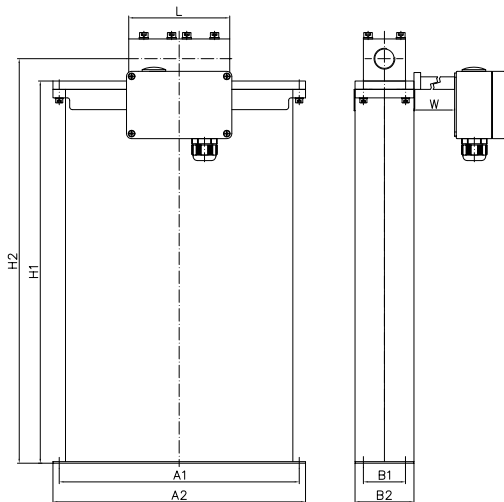

Process Connection	Face to face length (L)		Order Code
	mm	in	
Female Thread G 3/4"	120	4.72	G1
Female Thread 3/4" NPT	120	4.72	N1

The sensor is manufactured with two internal measurement tubes arranged side by side. In parallel or dual path sensors, these tubes are connected in parallel and the flowing fluid is split equally between them. In serial or single path sensors, the tubes are connected end to end creating a single path through which all fluid flows. For customization of face to face length and/or special fittings other than the ones listed on this page, please consult factory. *Note that larger diameter flange process connections are always possible.*

Common Dimensions

A1 = 285 mm (11.22 in) A2 = 300 mm (11.81 in) B1 = 50 mm (1.97 in) B2 = 70 mm (2.76 in) H1 = 454 mm (17.87 in) H2 = 481 mm (18.94 in)
 W: temp. range T1, TA = 0 mm (0 in), temp. range T2 = 150 mm (5.91 in)
 Electrical box: std. = 125 x 80 x 58 mm (4.92 x 3.15 x 2.28 in), RHE16 compact = 120 x 120 x 80 mm (4.72 x 4.72 x 3.15 in)

For weights and packaging dimensions please see last page of the Mechanical Construction section.

RHM12 Mechanical Construction

PFO: Seal-less parallel measuring tube construction with flange connections

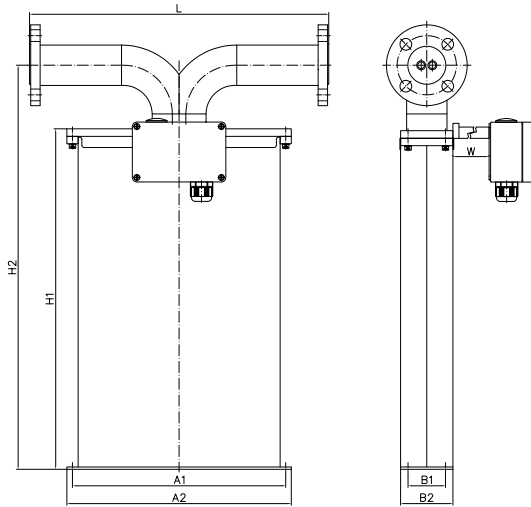

Process Connection	Face to face length (L)		Order Code
	mm	in	
ANSI 1" 150# RF	400	15.75	A1
ANSI 1" 300# RF	400	15.75	A2
ANSI 1" 600# RF	400	15.75	A3
ANSI 1" 1500# RF	400	15.75	A6
ANSI 1" 600# RTJ	400	15.75	R3
ANSI 1" 1500# RTJ	400	15.75	R1
ANSI 1" 2500# RTJ	400	15.75	R2
DIN DN25/PN40	400	15.75	D1
DIN DN25/PN100	400	15.75	D2
DIN DN25/PN160	400	15.75	D4
JIS RF 10k 25A (1")	400	15.75	J1
JIS RF 20k 25A (1")	400	15.75	J2
Grayloc 1½" GR11 Hub	400	15.75	H3

PFT: Seal-less parallel measuring tube construction with thread and compression fitting connections

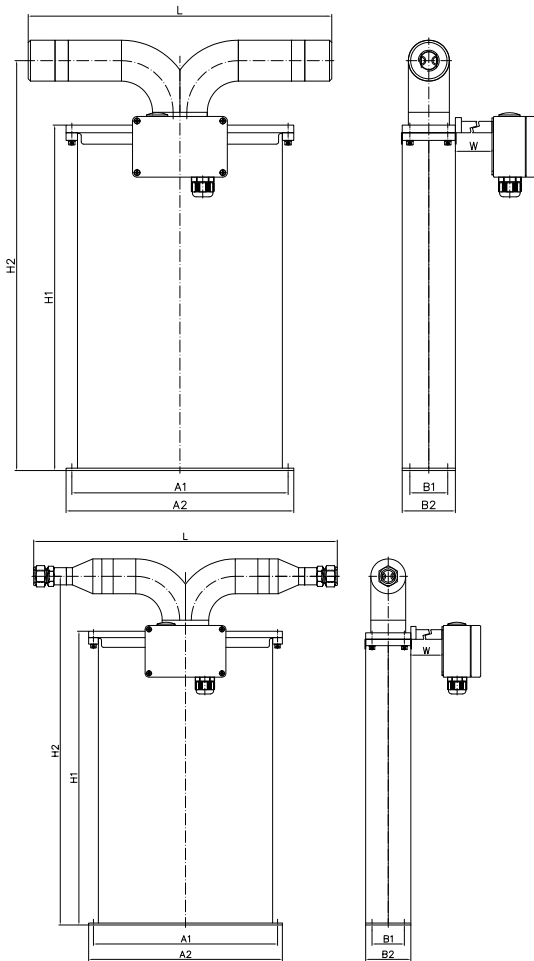

Process Connection	Face to face length (L)		Order Code
	mm	in	
Female Thread G ¾"	400	15.75	G1
Female Thread ¾" NPT	400	15.75	N1
Swagelok ¾" tube compression fitting (SS-1210-1-12W)	470	18.50	W1

The sensor is manufactured with two internal measurement tubes arranged side by side. In parallel or dual path sensors, these tubes are connected in parallel and the flowing fluid is split equally between them. For customization of face to face length and/or special fittings other than the ones listed on this page, please consult factory.
Note that larger diameter flange process connections are always possible.

Common Dimensions

A1 = 285 mm (11.22 in) A2 = 300 mm (11.81 in) B1 = 50 mm (1.97 in) B2 = 70 mm (2.76 in) H1 = 454 mm (17.87 in) H2 = 540 mm (21.26 in)
 W: temp. range T1, TA = 0 mm (0 in), temp. range T2, T3, T4 = 150 mm (5.91 in)
 Electrical box: std. = 125 x 80 x 58 mm (4.92 x 3.15 x 2.28 in), RHE16 compact = 120 x 120 x 80 mm (4.72 x 4.72 x 3.15 in)

For weights and packaging dimensions please see last page of the Mechanical Construction section.

RHM12 Mechanical Construction

SFO: Seal-less serial measuring tube construction with sanitary connections*

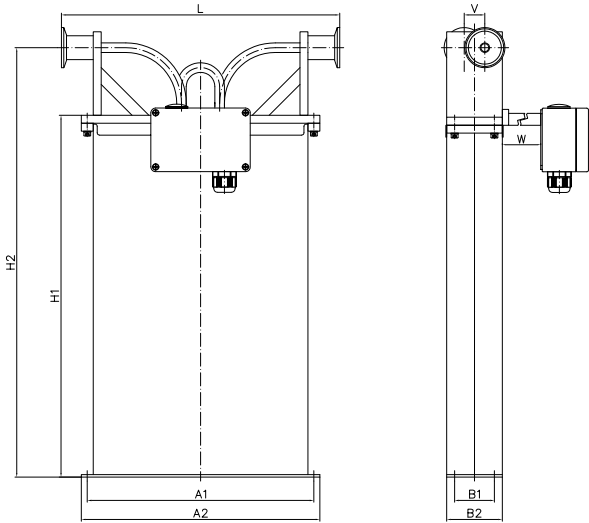

Process Connection	Face to face length (L)		Order Code
	mm	in	
Sanitary 1" Triclamp, DIN 32676	350	13.78	S0**
Sanitary NW20, DIN 11851	350	13.78	S4**

SFO: Seal-less serial measuring tube construction with flange connections*

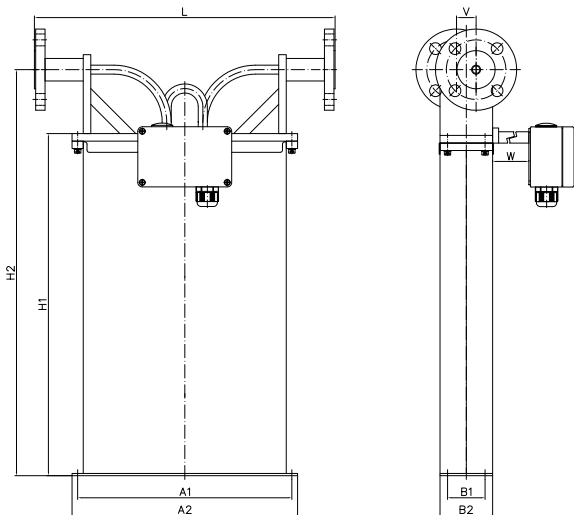

Process Connection	Face to face length (L)		Order Code
	mm	in	
ANSI 1" 150# RF	400	15.75	A1
ANSI 1" 300# RF	400	15.75	A2
DIN DN25/PN40	400	15.75	D1
DIN DN40/PN40	400	15.75	D7

The sensor is manufactured with two internal measurement tubes arranged side by side. In serial or single path sensors, the tubes are connected end to end creating a single path through which all fluid flows. For customization of face to face length and/or special fittings other than the ones listed on this page, please consult factory.
Note that larger diameter flange process connections are always possible.

Common Dimensions

A1 = 285 mm (11.22 in) A2 = 300 mm (11.81 in) B1 = 50 mm (1.97 in) B2 = 70 mm (2.76 in) H1 = 454 mm (17.87 in) H2 = 540 mm (21.26 in)
 V = 26 mm (1.02 in)

W: temp. range T1, TA = 0 mm (0 in), temp. range T2, T3, T4 = 150 mm (5.91 in)

Electrical box: std. = 125 x 80 x 58 mm (4.92 x 3.15 x 2.28 in), RHE16 compact = 120 x 120 x 80 mm (4.72 x 4.72 x 3.15 in)

* SFO meters are constructed with offset inlet/outlet ports. Consideration should be given to the offset (dimension V) when planning installation.

**P_{max} for sanitary fittings is 40 bar (580 psi).

Weights and Shipping Dimensions

Typical weight for standard manifold construction (PM0/SM0) sensor with female threads: approx. 14 kg (31 lb).

Typical weight for standard seal-less construction (PF0/SFO) sensor with 150# flanges: approx. 16 kg (35 lb).

RHM12 sensors typically ship on a pallet approx. 70 x 40 x 55 cm (27.6 x 15.7 x 21.7 in) complete with transmitter and cable.

Typical gross shipping weight example: RHM12 seal-less construction sensor with 150# flanges c/w RHE08 transmitter approx. 27 kg (60 lb).

RHM12 Part Number Code

Temperature Range

- T1 -20°C to +120°C (-4 to +248°F) (std.)
- TA -45°C to +120°C (-49 to +248°F)
- T2 -45°C to +210°C (-49 to +410°F)
- T3 -196°C to +50°C (-320 to +122°F)
- T4 0°C to +350°C (+32 to +662°F)

P_{max} of Measuring Tubes (see pressure rating page)

- P1 P_{max} depends upon material
- P2 P_{max} depends upon material

Construction Type (P_{max} @ 120°C (248°F))

- PM0 Parallel manifold, P_{max} = 290 bar (4206 psi) with thread, 214 bar (3104 psi) with flange
- SM0 Serial manifold, P_{max} = 260 bar (3771 psi) with thread, 214 bar (3104 psi) with flange
- PFO Parallel path, seal-less
- SFO Serial path, seal-less, P_{max} = 246 bar (3568 psi)
- PFT Parallel path, seal-less for thread connection, P_{max} = 250 bar (3626 psi)

Material of Wetted Parts

- M1 1.4571 (316Ti) (std.)
- M3 2.4602 (Alloy C22), seal-less construction types only
- M4 Tantalum, PFO construction type only, max. ANSI 300/PN40
- 62 1.4462 (Duplex), PFO construction type only
- 10 1.4410 (Super Duplex), PFO construction type only

Process Connection

See mechanical construction pages for available connections and codes

Options Codes

See options listing for specific codes

Terminal Box Selection

- 9 Remote transmitter cable termination box (std.)
- C Enclosure for compact mount RHE16 transmitter

Hazardous Area Certifications

- N Without Ex approval
- A ATEX approval Zone 0: Ex II 1 G Ex ia IIC T1-T6 Ga
- 2 ATEX rating Zone 2: Ex II 3 G Ex nA IIC T1-T6 Gc
- C CSA approvals USA-Canada Class I, Div. 1, Gr. A, B, C, D

Pressure Design Compliance

- NN No specific design compliance required
- SE PED (SEP) [Europe]
- CA CRN (Alberta Province) [Canada]
- CR CRN (All other Provinces) [Canada]

Mass Flow Calibration Selection

See performance page for code options

Density Calibration Selection

- D 1% Accuracy (std.)
- S 0.5% Accuracy



Options

H1	Hot oil/steam heating matrix for housing, DN15 PN40	SH	Housing in 316Ti stainless steel
H2	Hot oil/steam heating matrix for housing, ½" ANSI 150 RF	WH	Fully welded/sealed housing
H3	Hot oil/steam heating matrix for housing, ½" ANSI 300 RF	DY	Dye penetrant inspection
HF	Hot oil/steam trace heating for flange	XR	X-ray test – PFT, PM0 (flange), SM0 (flange) types only
P2	Housing purge for dry gas – ¼" NPT (2 pcs)	O	Oil/grease free cleaning