



RHM100

Coriolis Mass Flow Meter for High Flow Terminal and Transfer Applications

Features

- Standard pressure ratings up to 237 bar (3437 psi)
- Temperature ratings from -196 to 210°C (-320 to 410°F)
- Mass flow uncertainty down to 0.15%
- Density uncertainty down to 0.5%
- Repeatability better than 0.05%
- Typical measuring ranges between 300 and 12000 kg/min
- Accurately measure low flow rates down to 200 kg/min
- Unique robust torsion driven oscillation system
- Process connection customization available
- Approved for use in hazardous areas
- Stainless steel case
- Remote and compact transmitter versions available

Applications

Typical applications include:

- Terminal Transfer
- Viscous Fluids
- Barge, Ship, Rail Car and Truck Filling

Benefits

- Torsion oscillator design assures a stable and drift free measurement with excellent signal to noise ratios
- Resilient to external noise and vibration
- Insensitive to pipe pressure changes
- Robust tube wall thickness provides increased operational safety in abrasive applications
- Corrosion resistant
- Long sensor life guaranteed due to low mechanical stresses in the meter mechanism
- No moving parts to wear or fail

RHM100 General Specifications

Nominal Max Flow Range:	12000 kg/min (26456 lb/min)
Density Range:	5 to 5000 kg/m ³ (0.31 to 312 lb/ft ³)
Temperature Range:	4 temperature range options cover temperatures from -196°C to 210°C (-320°F to 410°F)
Pressure Ratings:	Dependent upon material
Electrical Connection:	Cable entry M25 x 1.5 (standard) M20 x 1.5, ½" NPT, ¾" NPT (optional) Max cable length to remote RHE transmitter 30m (98 ft). 100m (330ft) with optional high performance cable
Sensor Housing Materials:	1.4301 / 304 stainless steel (standard), 1.4571 / 316Ti stainless steel (optional) Epoxy coated aluminium electrical box (standard), 1.4571 / 316Ti stainless steel (optional)
Enclosure Type:	Protection Class IP 65. Optional IP 66 / NEMA 4X
Material of Wetted Parts:	Sensors are available in a variety of standard and custom materials to suit a wide range of pressure ratings and chemical compatibility requirements. See the pressure ratings listing in this document for further details
Finishes:	ANSI flange finish: AARH 125 to 250 µm, Ra 3.2 to 6.3 µm
Certifications and Approvals:	ATEX approval Zone 0: Ex II 1 G Ex ia IIC T1-T6 Ga ATEX rating Zone 2: Ex II 3 G Ex nA IIC T1-T6 Gc CSA USA-Canada, Class I, Div. 1, Groups A, B, C, D PED according to 97/23/EC Module B + C1 CRN for all Canadian Provinces
Documentation:	All sensors are supplied with a traceable calibration certificate. Optional documentation items available: - Traceable material certificates - Certificates of origin and conformity - Welding - NACE - Quality - Production and manufacturing procedures Other documentation to client requirements available
Proof Testing:	Hydrotest, dye penetrant, x-ray, PMI
Options:	Enclosure heating matrix for elevated temperature applications

Transmitter Range



RHE07



RHE08



RHE11



RHE12

Any Rheonik Mass Flow Transmitter model can be combined with an RHM100 sensor to provide an overall mass flow measurement system to suit any requirement. Rheonik Coriolis transmitters are designed for process, industrial and OEM applications. Together they offer a tremendous range of options for system designers and end users alike.

RHM100 Measurement Performance

Standard Calibration		
Flow Rate		Uncertainty
kg/min	lb/min	in % of reading
12000**	26455	0.20
6000	13228	0.20
3000	6614	0.20
800	1764	0.20
300	661	0.50

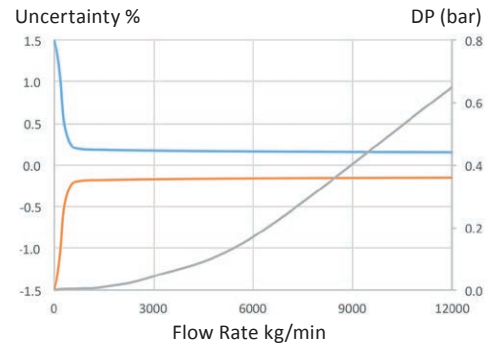

Goldline Calibration*		
Flow Rate		Uncertainty
kg/min	lb/min	in % of reading
9000	19842	0.15
7000	15432	0.15
5000	11023	0.15
3000	6614	0.15
1800	3968	0.15

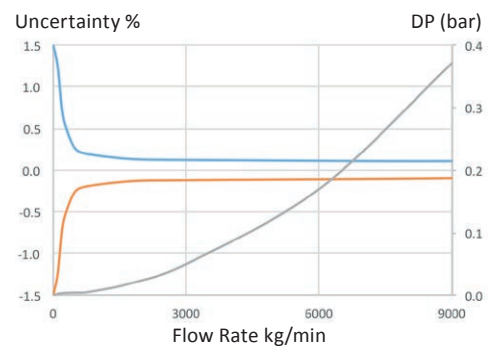

Low Flow Calibration*		
Flow Rate		Uncertainty
kg/min	lb/min	in % of reading
12000**	26455	0.20
6000	1328	0.20
800	1764	0.20
300	661	0.50
200	441	0.60

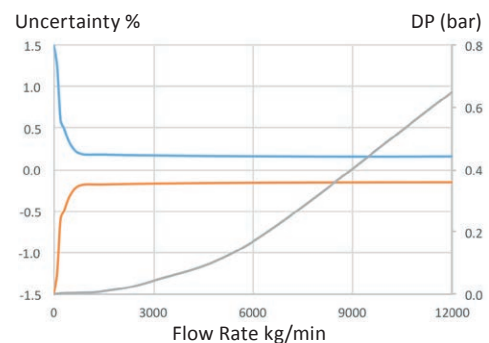

*Goldline and Low Flow Calibration is not available with all configurations of the RHM100. Please check with factory.

**Calibration at factory only up to 11,000 kg/min.

Mass Flow Calibration Options	
A	40:1 Standard Calibration – 0.5% Uncertainty between 12000 and 300 kg/min
B	15:1 Standard Calibration – 0.2% Uncertainty between 12000 and 800 kg/min
G	5:1 Goldline Calibration – 0.15% Uncertainty between 9000 and 1800 kg/min
2	Low Flow Calibration – 0.2% Uncertainty between 12000 and 800 kg/min, 0.5% between 800 and 300 kg/min, 0.7% between 300 and 200 kg/min

- Uncertainty of reading (incl. zero drift) stated at reference condition of: H₂O, 18-24°C (66-76°F), 1-3 bar (15-45 psi) when installed according to field manual
- Pressure drop indications are based upon H₂O flowing in a meter with P1 pressure rating
- For customized calibration range or uncertainty levels, please consult factory

Flow Measurement Repeatability

Standard ± 0.1% of rate

Goldline ± 0.05% of rate

Density Measurement Performance (liquids)

Standard 2 point calibration ±1% of value

Optional 3 point calibration ±0.5% of value

Gas density – depends upon pressure

Temperature

Better than ± 1°C

RHM100 Pressure Ratings

The maximum pressure (P_{max}) of a sensor is determined by its lowest rated part. The lowest rated part is either the measuring tube (P_{max} indicated below) or the process connection (for P_{max} see published standards or manufacturer information).

RHM100 Measurement Tube Pressure Ratings

Pressure Code	Material Code	Material	P_{max}				
			bar	psi		°C	°F
P0 (std.)	M1 (std.)	1.4571 (316Ti) UNS S31635	73	1059	@	50	122
			66	957	@	120	248
			57	827	@	210	410
PA	M1 (std.)	1.4571 (316Ti) UNS S31635	99	1436	@	50	122
			88	1276	@	120	248
			76	1102	@	210	410
PA	10*	1.4410 (Super Duplex) UNS S32750	237	3437	@	50	122
			208	3017	@	120	248
			188	2727	@	210	410
PA	62*	1.4410 (Super Duplex)	189	2741	@	50	122
			166	2408	@	120	248
			145	2103	@	210	410
P1	M3	2.4602 (Alloy C22) UNS N06022	113	1639	@	50	122
			100	1450	@	120	248
			85	1233	@	210	410

*Only with T1, TA, T2 temperature range (note min. temp. is -40°C).

Other Materials

Additional/custom wetted materials (Inconel, Monel, 304 stainless steel, others) may be possible for chemical compatibility, lower pressure drop, abrasion allowance, other application specific requirements.

Contact factory with specification for assessment and availability.

RHM100 Mechanical Construction

PFO: Seal-less parallel measuring tube construction with flange connections

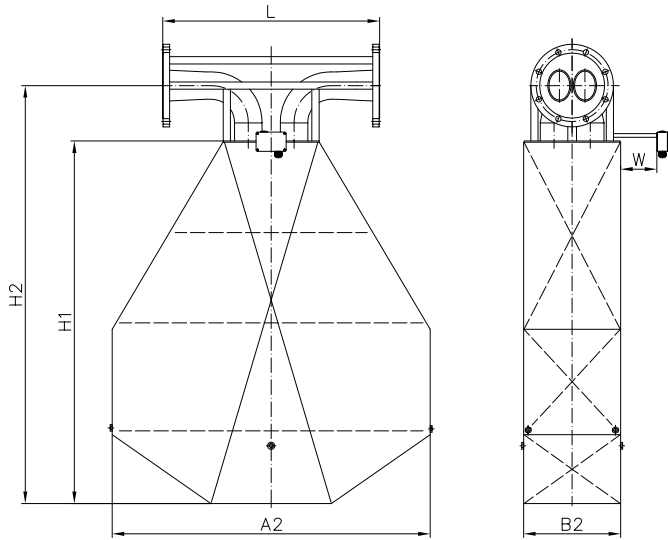

Process Connection	Face to face length (L)		Order Code
	mm	in	
ANSI 8" 150# RF	900	35.43	A1
ANSI 8" 300# RF	900	35.43	A2
ANSI 8" 600# RF*	900	35.43	A3
ANSI 8" 900# RF*	900	35.43	A4
ANSI 8" 1500# RF*	900	35.43	A5
ANSI 8" 900# RTJ*	900	35.43	R3
ANSI 8" 1500# RTJ*	900	35.43	R4
DIN DN200/PN16	900	35.43	D1
DIN DN200/PN40	900	35.43	D2
DIN DN200/PN100*	900	35.43	D3
JIS RF 10k 200A (8")	900	35.43	J1
JIS RF 20k 200A (8")	900	35.43	J2

For customization of face to face length and/or special fittings other than the ones listed on this page, please consult factory.
Note that larger diameter flange process connections are always possible.

A2 = 1320 mm (51.97 in) B2 = 403 mm (15.87 in) H1 = 1505 mm (59.25 in) H2 = 1735 mm (68.31 in) W = 150 mm (5.91 in)
 Electrical box: std. = 125 x 80 x 58 mm (4.92 x 3.15 x 2.28 in), RHE16 compact = 120 x 120 x 80 mm (4.72 x 4.72 x 3.15 in)

*This flange selection will reduce maximum allowable measurement tube pressure rating by a factor of 0.75.

Weights and Shipping Dimensions

Typical weight with 8" 150# flanges: approx. 520 kg (1146 lb).

RHM100 meters ship in a wooden crate (to ISPM 15). Typical dimensions approx. 220 x 160 x 90 cm (87 x 63 x 36 in).

Typical gross shipping weight example: RHM100 with 8" 150# flanges c/w RHE08 transmitter approx. 750 kg (1654 lb).

