

## In-Line Flow Meter Series 504FTB

The Kurz 504FTB in-line thermal mass flow meter for applications ranging from vacuum service up to 300 PSIG includes the qualities and features found in all Kurz constant temperature thermal flow meters that make them outperform all other currently available thermal mass flow meters, including:

- The highest repeatability, accuracy, and reliability available
- The fastest response to temperature and velocity changes in the industry
- Constant temperature thermal technology
- High turndown ratio
- Low flow noise
- Continuous self-monitoring electronics that verify the integrity of sensor wiring and measurements
- Sensors do not overheat at zero flow using a unique constant temperature control method and power limiting design
- Sensor lead length independent circuitry
- Zero velocity as a valid data point
- Completely field configurable using the local user interface or via a computer connection
- Velocity-temperature mapping for wide ranging velocity and temperature
- User-programmable dual gas mix interpolation
- Flexibility with transmitter-attached or transmitter-separate designs
- Patent US 7,418,878

Kurz Instruments is dedicated to manufacturing and marketing the best thermal mass flow meters available and to support our customers in their efforts to improve their businesses.

### Applications

- Process & specialty gases
- Compressed air
- Fuel flow
- Natural gas metering
- Solvent & VOC recovery
- NOx control using ammonia
- Flow calibration
- Air sampling



**Kurz Instruments, Inc.**  
2411 Garden Road  
Monterey, CA 93940  
800-424-7356  
[www.KurzInstruments.com](http://www.KurzInstruments.com)



## SPECIFICATIONS

- **Mass flow range**  
Up to 4,000 SCFM (6,240 NCMH)  
depending on model and calibration option
- **Flow accuracy** (SCFM at laboratory conditions)  
 $\pm$  (1% of reading + (A x 20 SFPM))  
where A is the flow area of the 504FTB
- **0.25% reading repeatability**
- **Velocity time constant**  
1 second for velocity changes at  
6,000 SFPM (constant temperature)
- **Process temperature time constant**  
8 seconds for temperature changes at  
6,000 SFPM (constant velocity)
- **Temperature accuracy**  
 $\pm$  (0.5% of reading +1°C) for velocities above  
100 SFPM
- **Electronics operating temperature**  
Integral display  
-13°F to 149°F (-25°C to 65°C)  
Remote aluminum display  
-40°F to 149°F (-40°C to 65°C)  
Remote polycarbonate display  
-13°F to 122°F (-25°C to 50°C)

## PROCESS CONDITIONS

- **Process pressure rating**  
Up to 300 PSIG (20 BARg)
- **Process temperature rating**  
-40°F to 257°F (-40°C to 125°C)

## APPROVALS

- **EPA mandatory GHG certification**  
40 CFR 98.34(c)(1)
- **Alarm output conformity**  
NAMUR NE43
- **European Union CE compliance**  
EMC, LVD, PED, ROHS, and WEEE
- **Functional safety approval**  
TUV Rheinland SIL1
- **CSA, ATEX & IECEx approvals for Nonincendive, Flameproof, and Explosion-proof**  
EN IEC 60079-0, EN IEC 60079-1  
EN IEC 60079-15, CSA Class 1, Div. 1 and 2

## TRANSMITTER FEATURES

- **Aluminum (Type 4, IP66) dual chamber polyester powder-coated enclosure**
- **Optically-isolated 4-20 mA output**  
12-bit resolution and accuracy  
Maximum loop resistance is  
500Ω at 18 V DC, 800Ω at 24 V DC,  
1400Ω at 36 V DC
- **Input power**  
AC (85-264 V 50/60 Hz, 24 watts max.)  
or DC (24 V  $\pm$ 10%), 1 A max.
- **Solid state relays**  
Optically isolated,  
0.5 A, 24 V AC/DC maximum
- **Integral or remote user interface**  
Easy-to-use interface  
Backlit display / keypad  
2-lines of 16-characters each
- **User-configurable flow display (scrolling or static)**
- **User-configurable English or metric units for mass flow rate, mass velocity, or process temperature**  
°C, °F, KGH, KGM, NCMH, NLPM, NMPS, PPD,  
PPH, PPM, SCFH, SCFM, SCMh, SLPM
- **User-programmable dual gas mix interpolation**
- **Built-in flow totalizers and elapsed time**
- **User-configurable digital filtering from 0 to 600 seconds**
- **Configuration/data access**  
USB, RS-485 Modbus (ASCII or RTU), or HART
- **Meter memory**  
200 recent events, top 20 min/max, and  
56 hours (10 second samples of trends)
- **3-year warranty**

## SUPPORT & ELEMENT COMPONENTS

- **Sensor material**  
C-276 alloy all-welded sensor  
construction
- **Sensor support**  
316L stainless steel
- **Sensor flow body diameter options**  
Available from 3/8" to 4"
- **Connection type**  
Raised-face flange (Class 150 ANSI B16.5 or  
Class 300 ANSI B16.5) or MNPT pipe ends
- **3-year warranty**

## OPTIONS

- **Adjustable display/keypad orientation**
- **Remote enclosure: aluminum or polycarbonate**
- **HART communication, v7 FSK**  
Process control industry standard  
allows remote configuration, diagnostic  
monitoring, and online testing with  
handheld configurators
- **Two optically isolated solid-state relays / alarms**  
Configurable as alarm outputs or pulsed  
totalizer output
- **Digital input dedicated to zero-mid-span drift check**
- **Pulsed output as a remote flow totalizer**
- **Hardware accessories**  
Available hardware includes ball valves, cable  
glands, conduit seals, and cable





## PROCESS TEMPERATURE & COMPENSATION

Temperature influences the physical properties of gases, so temperature compensation is required for a thermal sensor to accurately measure gas flow rates.

- **Standard Temperature Compensation (STC)** is used for process temperatures from 0°C to 125°C over a moderate velocity range.
- **Velocity Temperature Mapping (VTM)** is used when the process temperature and gas velocity vary widely. Multiple velocity calibrations are stored in the meter. VTM compensation is based on air; specific gas correlations are required to ensure accuracy at high temperatures.

## SPECIALTY GAS VELOCITY CALIBRATION

There are two types of gas calibration:

- **Laboratory gas calibrations** are performed with gases of high purity and are NIST traceable. Values above the calibrating facility limit are correlated up to the specified range. Customers must specify the calibration process pressure.
- **Correlation gas calibrations** are based on experimental data correlated to an Air calibration at ambient pressure and temperature. The flow element is calibrated in Air, and then an additional calibration data sheet is generated using the correlation factors. All correlation calibrations include velocity-temperature mapping.

Add  $\pm 5\%$  of reading to the accuracy specification when using a correlation calibration.

For Oxygen gas, the customer is responsible for ensuring the mass flow sensor is clean of hydrocarbons and safe for Oxygen use.

## ANALOG & DIGITAL INPUTS

All options include USB, RS-485 interface with ASCII text and Modbus protocols, which are NAMUR NE-43 compliant.

The 4-20mA analog outputs (AO) are used for flow rate and/or temperature, or one AO for PID flow control.

Relay outputs (DO) can be alarms, EPA zero-mid-span drift is active, or pulsed totalizer function. PID uses one 4-20mA output for the flow controller. The EPA zero-mid-span drift check requires a contact closure to start the drift check. All 4-20mA outputs are used during the Drift Check Calibration process.

EPA zero-mid-span drift check can be initiated using Digital inputs (DI), elapsed runtime automatic drift check, Modbus, or HART.

The 4-20mA input (AI) supports feedback to the device.



## SERIES 504FTB OUTLINE DRAWINGS

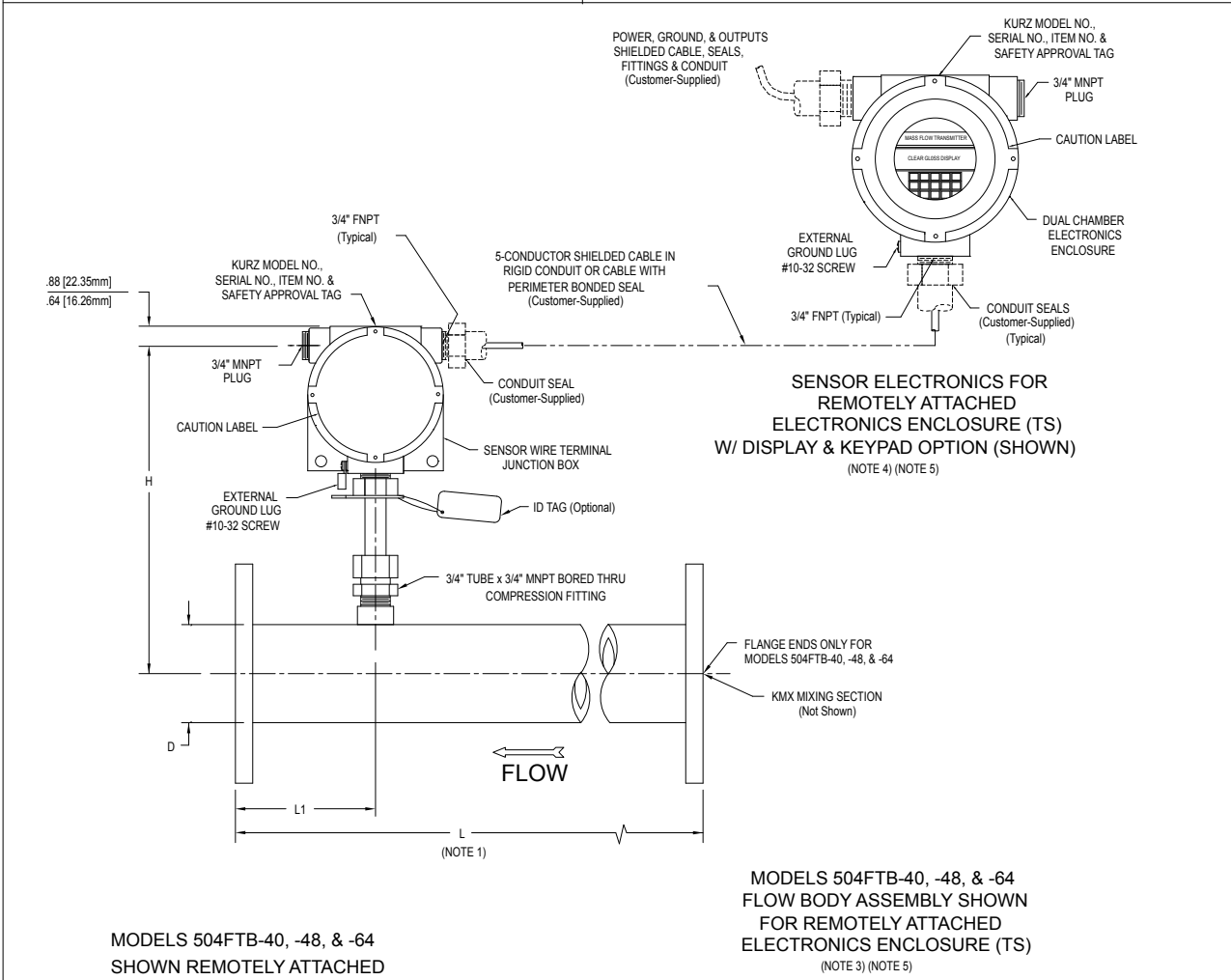
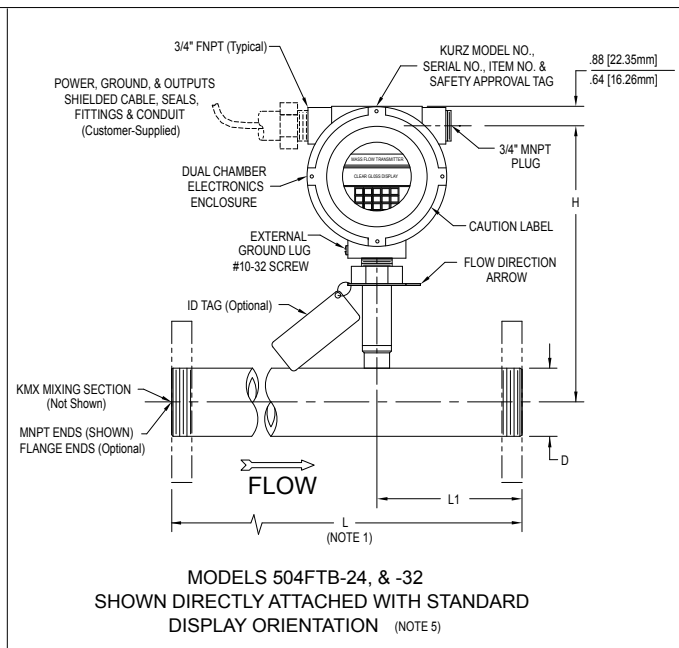
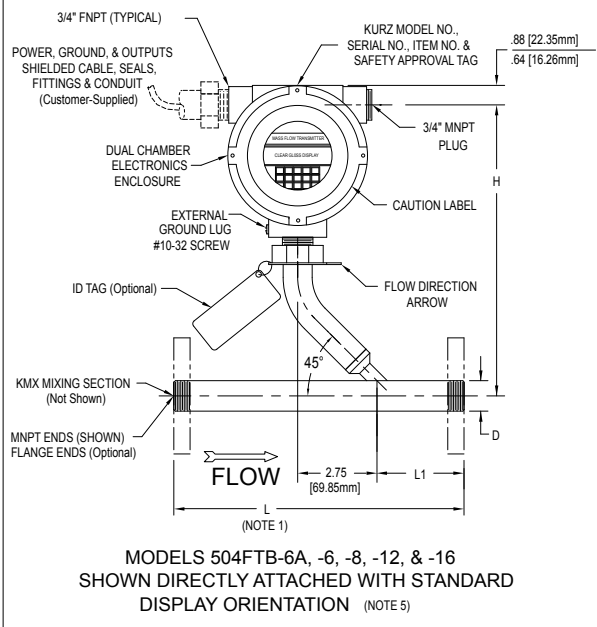

All units are in inches, unless otherwise specified.



## SERIES 504FTB OUTLINE DRAWINGS (cont'd)

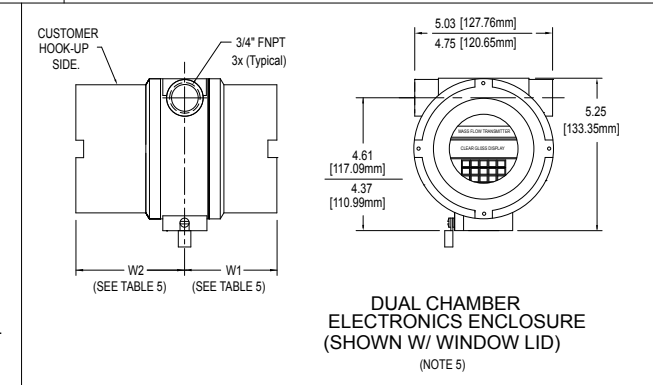
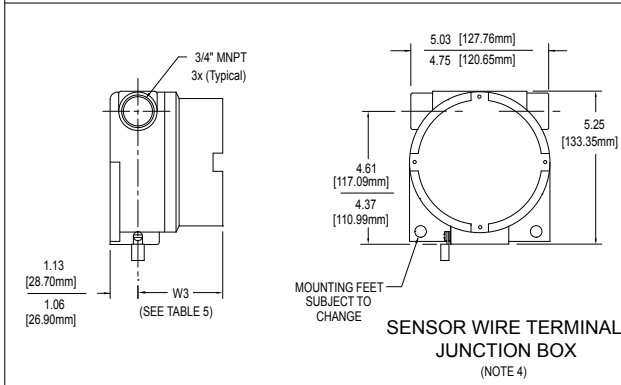
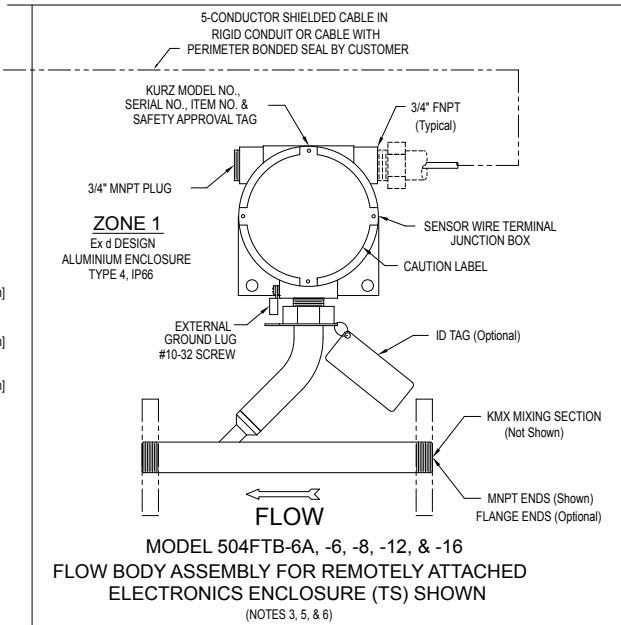
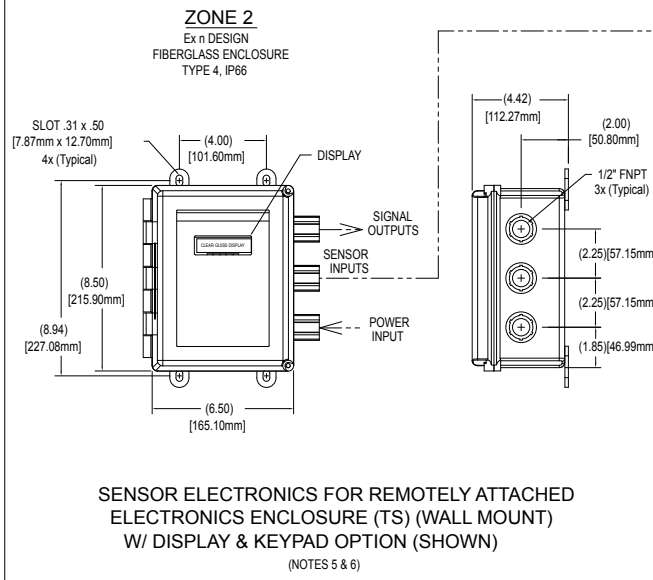

TABLE 4 SERIES 504FTB IN-LINE MASS FLOW TRANSMITTERS DIMENSIONS

MODEL NUMBER	NOMINAL PIPE SIZE (INCHES)	D INCHES [mm]	NOMINAL FLANGE SIZE (INCHES)	L (NOTE 1) INCHES [mm]	L1 INCHES [mm]	H INCHES [mm]	NET WEIGHT (APPROX.) LBS. [kg] (NOTE 2)		
							THREADED	CL150 FLANGED	CL300 FLANGED
504FTB-6A	3/8	0.675 [17.15mm]	1/2	7.00 [177.80mm]	2.50 [63.50mm]	9.94 [252.48mm]	7.00 [3.18kg]	9.00 [4.08kg]	11.00 [4.99kg]
504FTB-6	3/8	0.675 [17.15mm]	1/2	7.00 [177.80mm]	2.50 [63.50mm]	9.94 [252.48mm]	7.00 [3.18kg]	9.00 [4.08kg]	11.00 [4.99kg]
504FTB-8	1/2	0.840 [21.34mm]	1/2	8.00 [203.20mm]	3.00 [76.20mm]	10.02 [254.51mm]	7.50 [3.40kg]	9.50 [4.31kg]	11.50 [5.22kg]
504FTB-12	3/4	1.050 [26.67mm]	3/4	10.00 [254.00mm]	3.00 [76.20mm]	10.13 [257.30mm]	8.00 [3.63kg]	11.50 [5.22kg]	13.50 [6.12kg]
504FTB-16	1	1.315 [33.40mm]	1	12.00 [304.80mm]	3.50 [88.90mm]	10.25 [260.35mm]	8.50 [3.86kg]	12.50 [5.67kg]	14.50 [6.58kg]
504FTB-24	1-1/2	1.900 [48.26mm]	1-1/2	18.00 [457.20mm]	4.00 [101.60mm]	9.30 [236.22mm]	10.50 [4.67kg]	19.00 [8.62kg]	23.00 [10.43kg]
504FTB-32	2	2.375 [60.33mm]	2	24.00 [609.60mm]	5.00 [127.00mm]	9.54 [242.32mm]	14.00 [6.35kg]	24.00 [10.89kg]	30.00 [13.61kg]
504FTB-40	2-1/2	2.875 [73.03mm]	2-1/2	24.00 [609.60mm]	5.00 [127.00mm]	11.78 [299.21mm]	N/A	32.50 [14.74kg]	42.50 [19.28kg]
504FTB-48	3	3.500 [88.90mm]	3	24.00 [609.60mm]	5.00 [127.00mm]	11.78 [299.21mm]	N/A	40.00 [18.14kg]	54.00 [24.49kg]
504FTB-64	4	4.500 [114.30mm]	4	24.00 [609.60mm]	5.00 [127.00mm]	11.78 [299.21mm]	N/A	62.50 [28.35kg]	82.50 [37.42kg]

TABLE 5 ENCLOSURE DIMENSION (NOTE 5)

INPUT POWER	DISPLAY / KEYPAD	W1 (MAX.) (MIN.)	W2 (MAX.) (MIN.)	W3 (MAX.) (MIN.)
AC	YES	3.63 [92.20mm]	5.01 [127.25mm]	N/A
		3.41 [86.61mm]	4.69 [119.13mm]	
AC	NO	3.16 [80.26mm]	5.01 [127.25mm]	N/A
		2.81 [71.37mm]	4.69 [119.13mm]	
24VDC	YES	3.63 [92.20mm]	5.01 [127.25mm]	N/A
		3.41 [86.61mm]	4.69 [119.13mm]	
24VDC	NO (NOTE 4)	N/A	N/A	5.01 [127.25mm]
		N/A	N/A	4.88 [123.95mm]
SENSOR WIRE TERMINAL J-BOX (FOR REMOTE OPT.)		N/A	N/A	3.16 [80.26mm]
				2.81 [71.37mm]

- NOTES:
- 1) L DIMENSION IS OVERALL END TO END.
  - 2) WEIGHTS SHOWN ARE FOR DIRECTLY ATTACHED, AC POWER, WITH DISPLAY. FOR REMOTELY ATTACHED VERSIONS ADD 4.0 LBS. [1.82kg].
  - 3) THIS PROBE CONFIGURATION ALSO USED FOR DIRECTLY ATTACHED, DC POWERED, NO DISPLAY.
  - 4) SENSOR WIRE TERMINAL JUNCTION BOX USED FOR SENSOR ELECTRONICS, DC POWERED, NO DISPLAY.
  - 5) ENCLOSURE STYLES AND DIMENSIONS ARE SUBJECT TO CHANGE.
  - 6) THIS CONFIGURATIONS ALLOWS FOR PROBE ASSY TO BE MOUNTED IN ZONE 1 AREA AND FOR REMOTE ELECTRONICS TO BE MOUNTED IN ZONE 2 AREA.

All units are in inches, unless otherwise specified.



## STANDARD FULL-SCALE FLOW RATES

Table 1: Standard Full-Scale Flow Rate Ranges (Q<sub>max</sub>)

Model Number	Flow Area (ft <sup>2</sup> )	Laboratory <sup>1</sup> Calibration Range		Correlated <sup>2</sup> Calibration Range	
		SCFM	NCMH	SCFM	NCMH
504FTB-06A	0.00044	2	3.1	8	12.4
504FTB-06	0.00107	10	15.6	40	62.4
504FTB-08	0.00179	20	31	80	124
504FTB-12	0.00328	40	62	160	248
504FTB-16	0.00546	75	117	300	468
504FTB-24	0.01337	150	234	600	936
504FTB-32	0.02253	300	468	1200	1872
504FTB-40	0.03248	400	624	1600	2496
504FTB-48	0.05057	600	936	2400	3744
504FTB-64	0.08763	1000	1560	4000	6240

**Note:** 1. The baseline flow rate for each transmitter model number.  
2. Compressed air only.

SCFM	Standard Cubic Feet Per Minute, Reference: 77°F, 14.69 PSIA
NCMH	Normal Cubic Meters Per Hour, Reference 0°C, 760 mmHg NCMH = 1.56 x SFPM (approximate)

## ESTIMATED PRESSURE DROP

To compute the expected pressure drop for a flow rate, multiply the full scale pressure drop by the square of the flow ratio.

Table 2: Estimated Pressure Drop (DPs)

Gas Type	Inches H <sub>2</sub> O	mm H <sub>2</sub> O	kPa
Air	30	762	7.46
Argon	40	1016	9.95
Butane	18	457	4.47
Carbon Dioxide	45	1143	11.19
Dry Ammonia	18	457	4.47
Dry Chlorine	51	1295	12.69
Ethane	18	457	4.47
Ethylene	20	508	4.97
Helium	2	51	0.49
Hydrogen	1	25	0.24
Methane	15	381	3.73
Digester Gas: 50% CH <sub>4</sub> , 50% CO <sub>2</sub>	28	711	6.96
Digester Gas: 60% CH <sub>4</sub> , 40% CO <sub>2</sub>	25	635	6.22
Digester Gas: 70% CH <sub>4</sub> , 30% CO <sub>2</sub>	23	584	5.72
Nitrogen	29	737	7.21
Oxygen	33	838	8.21
Propane	14	356	3.48

**Note:** Estimated standard pressure drop is the end-to-end pressure drop at Standard Full-Scale Conditions listed in Table 1.



755 \_ \_ \_  
Parent Number

F1

F2

F3

F4

F5

F6

F7

F8

F9

F10

Parent Number	Model	Pipe Size & Length
755960	504FTB-06A	0.375" x 7" (10 x 178 mm)
755961	504FTB-06	0.375" x 7" (10 x 178 mm)
755962	504FTB-08	0.5" x 8" (13 x 203 mm)
755963	504FTB-12	0.75" x 10" (19 x 254 mm)
755964	504FTB-16	1" x 12" (25 x 305 mm)
755965	504FTB-24	1.5" x 18" (38 x 457 mm)
755966	504FTB-32	2" x 24" (51 x 610 mm)
755967	504FTB-40	2.5" x 24" (64 x 610 mm)
755968	504FTB-48	3" x 24" (76 x 610 mm)
755969	504FTB-64	4" x 24" (102 x 610 mm)

**Note:** Models 504FTB-06 to 504FTB-32 use the MD sensor type.  
Model s 504FTB-40 to 504FTB-64 use the FD2 sensor type.

F1	Option	Electronics Enclosure Configuration and Input Power
	A	Directly attached dual-chamber electronics enclosure, AC/DC power, display / keypad
	B	Directly attached dual-chamber electronics enclosure, AC/DC power, without display / keypad
	C	Directly attached dual-chamber electronics enclosure rotated 180° for viewing, AC/DC power, display / keypad
	D	Remote dual-chamber electronics enclosure, AC/DC power, display / keypad
	E	Remote dual-chamber electronics enclosure, AC/DC power, without display / keypad
	F	Directly attached dual-chamber electronics enclosure, DC power, display / keypad
	G	Directly attached dual-chamber electronics enclosure rotated 180° for viewing, DC power, display / keypad
	H	Directly attached single-chamber electronics enclosure, DC power, without display / keypad
	I	Remote dual-chamber electronics enclosure, DC power, display / keypad
	J	Remote single-chamber electronics enclosure, DC power, without display / keypad
	R	Remote polycarbonate electronics enclosure, AC power, with display / keypad
	S	Remote polycarbonate electronics enclosure, AC power, without display / keypad

F2	Sensor Material / Flow Body and Flange Material
	Choose one option from each category.

Option	Sensor Material
3	C-276 alloy

Option	Flow Body and Flange Material
2	316L stainless steel

F3	Option	Flow Body Connection Type	Pressure Rating
	A	Male NPT pipe ends (MNPT)	150 PSIG
	B	Class 150 ANSI B16.5 flanges (CL150)	150 PSIG
	C	Class 300 ANSI B16.5 flanges (CL300)	300 PSIG

F4	Option	Process Temperature Compensation
	1	Standard temperature compensation over process range of -40°C to 125°C for all gases. Accuracy: $\pm (1 + 2000 \times A/F) \%$ , where F = SCFM, A= flow body area (ft <sup>2</sup> )

**Note:** An accuracy specification of  $\pm 0.025\%/^{\circ}\text{C} = (A^*)/(0.25 \text{ SFPM}/^{\circ}\text{C})$  should be added for temperatures above or below standard.

F5	Gas Flow Rate Calibration Data Range			
	Option	Description	Option	Description
	A	100% Qmax	I	60% Qmax
	B	95% Qmax	J	55% Qmax
	C	90% Qmax	K	50% Qmax
	D	85% Qmax	L	45% Qmax
	E	80% Qmax	M	40% Qmax
	F	75% Qmax	N	35% Qmax
	G	70% Qmax	P	30% Qmax
	H	65% Qmax	Q	25% Qmax

**Note:** Refer to Table 1 and 2 to determine the correct selection for calibration range selection.



F6 Specialty Gas Velocity Calibration			
	Laboratory Calibration	Correlation Calibration	Description
	01	-	Ambient Air
	07	-	Compressed Air
	-	0K	Compressed Air (correlated to 4x full scale flow rate)
	-	56	Dry Ammonia
	08	58	Argon
	-	60	Butane
	14	64	Carbon Dioxide
	-	68	Dry Chlorine
	20	70	Ethane
	22	72	Ethylene
	26	76	Helium
	28	-	Hydrogen
	32	82	Methane
	35	85	Digester Gas 50% CH <sub>4</sub> 50% CO <sub>2</sub>
	36	86	Digester Gas 60% CH <sub>4</sub> 40% CO <sub>2</sub>
	37	87	Digester Gas 70% CH <sub>4</sub> 30% CO <sub>2</sub>
	40	90	Nitrogen
	44	94	Oxygen
	46	96	Propane
<b>Note:</b> Laboratory gas calibrations are performed with high purity gases and are NIST Traceable. Customers must specify process pressure (Feature 8). Propane to 50 PSIA, all other gases to 150 PSIA.			

F7	Option	Safety Approval
	A	Non-Incendive, CSA, ATEX, and IECEx Aluminum enclosures Type 4, IP66 Ex nA IIC Tx; Ex nA IIC Tx Gc; Class I Zone 2 AEx nA IIC Tx Gc Sensing element, Tp: -40°C to 55°C; T5 or to 130°C; T3 DC power electronics housing, Ta: -40°C to 65°C; T4 AC power electronics housing, Ta: -40°C to 50°C; T4 or to 65°C; T150°C
	B	Explosion-Proof/Flame-Proof, CSA, ATEX, and IECEx Aluminum enclosures Type 4, IP66 Ex d IIB + H <sub>2</sub> Tx; Ex d IIB + H <sub>2</sub> Tx Gb; Class I Zone 1 AEx d IIB + H <sub>2</sub> Tx Gb Sensing element, Tp: -40°C to 45°C; T4 or to 110°C; T3 DC power electronics housing, Ta: -40°C to 65°C; T4 AC power electronics housing, Ta: -40°C to 50°C; T4 or to 65°C; T150°C (T3)
	D	Transmitter and sensing element separate Sensor enclosure: Aluminum Type 4, IP66 Electronics enclosure: Polycarbonate Type 4, IP54 (Feature 1, Option R or S) Sensing element: Ex d IIB + H <sub>2</sub> Tx; Ex d IIB + H <sub>2</sub> Tx Gb; Class I Zone 1 AEx d IIB + H <sub>2</sub> Tx Gb, Tp: -40°C to 45°C; T4 or to 110°C; T3 AC power electronics housing: Ex nA IIC Tx; Ex nA IIC Tx Gc; Class I Zone 2 AEx nA IIC Tx Gc, Ta: -25°C to 50°C; T4

F8	Option	Process Pressure
	---	Enter the Absolute Pressure (PSIA) rounded to 3 digits. For example, a process Absolute Pressure of 14.7 PSIA, round to 15.0 and enter 015; for 150 PSIA enter 150.

F9	Option	Analog and Digital Inputs/Output	
	B	Standard	Two 4-20mA isolated outputs
	C	Full	Two 4-20mA isolated outputs, two relays, two digital inputs, one non-isolated 4-20mA input
	E	HART-1	One 4-20mA isolated output, two relays, two digital inputs, one non-isolated 4-20mA input

F10	Option	Process Temperature
	---	Enter the Absolute Temperature (°Rankin = °F + 460) rounded to 3 digits. For example, a Process Temperature of 77°F is written as 537 (77 + 460).