

GasAlert
MicroClip^{XT}

1, 2, 3, and 4-Gas Detector

Operator's Manual

BW
Technologies
by Honeywell

Limited Warranty and Limitation Liability

BW Technologies LP (BW) warrants the product to be free from defects in material and workmanship under normal use and service for a period of two years, beginning on the date of shipment to the buyer. This warranty extends only to the sale of new and unused products to the original buyer. BW's warranty obligation is limited, at BW's option, to refund of the purchase price, repair or replacement of a defective product that is returned to a BW authorized service center within the warranty period. In no event shall BW's liability hereunder exceed the purchase price actually paid by the buyer for the Product.

This warranty does not include:

- a) fuses, disposable batteries or the routine replacement of parts due to the normal wear and tear of the product arising from use;
- b) any product which in BW's opinion, has been misused, altered, neglected or damaged, by accident or abnormal conditions of operation, handling or use;
- c) any damage or defects attributable to repair of the product by any person other than an authorized dealer, or the installation of unapproved parts on the product; or

The obligations set forth in this warranty are conditional on:

- a) proper storage, installation, calibration, use, maintenance and compliance with the product manual instructions and any other applicable recommendations of BW;
- b) the buyer promptly notifying BW of any defect and, if required, promptly making the product available for correction. No goods shall be returned to BW until receipt by the buyer of shipping instructions from BW; and
- c) the right of BW to require that the buyer provide proof of purchase such as the original invoice, bill of sale or packing slip to establish that the product is within the warranty period.

THE BUYER AGREES THAT THIS WARRANTY IS THE BUYER'S SOLE AND EXCLUSIVE REMEDY AND IS IN LIEU OF ALL OTHER WARRANTIES, EXPRESS OR IMPLIED, INCLUDING BUT NOT LIMITED TO ANY IMPLIED WARRANTY OF MERCHANTABILITY OR FITNESS FOR A PARTICULAR PURPOSE. BW SHALL NOT BE LIABLE FOR ANY SPECIAL, INDIRECT, INCIDENTAL, OR BASED ON CONTRACT, TORT OR RELIANCE OR ANY OTHER THEORY.

Since some countries or states do not allow limitation of the term of an implied warranty, or exclusion or limitation of incidental or consequential damages, the limitations and exclusions of this warranty may not apply to every buyer. If any provision of this warranty is held invalid or unenforceable by a court of competent jurisdiction, such holding will not affect the validity or enforceability of any other provision.

Contacting BW Technologies by Honeywell

USA: 1-888-749-8878

Canada: 1-800-663-4164

Europe: +44(0) 1295 700300

Other countries: +1-403-248-9226

Email us at: info@gasmonitors.com

Visit BW Technologies by Honeywell's website at: www.gasmonitors.com

GasAlertMicroClip XT

Introduction

The operator's manual provides basic information for the GasAlertMicroClip XT. For complete operating instructions, refer to the *GasAlertMicroClip XT Technical Reference Guide* provided on the CD-ROM. The GasAlertMicroClip XT ("the detector") warns of hazardous gas at levels above user-defined alarm setpoints. The detector is a personal safety device. It is your responsibility to respond properly to the alarm.

Note

The detector is shipped with English as the default displayed language. Additional languages provided are Portuguese, Spanish, German, and French. The screens for the additional languages are displayed on the detector and in the corresponding operator's manuals.

Zeroing the Sensors

To zero the sensors, refer to steps #1-3 in Calibration on page 7.



This instrument contains a lithium polymer battery. Dispose of lithium cells immediately. Do not disassemble and do not

dispose of in fire. Do not mix with the solid waste stream. Spent batteries should be disposed of by a qualified recycler or hazardous materials handler.

Safety Information - Read First

Use the detector only as specified in this manual and the reference guide, otherwise the protection provided by the detector may be impaired. Read the following cautions before using the detector.

⚠ Cautions

- **Warning:** Substitution of components may impair Intrinsic Safety.
- **Caution:** For safety reasons, this equipment must be operated and serviced by qualified personnel only. Read and understand the user manual completely before operating or servicing.
- **Charge the detector before first time use.** BW recommends the detector be charged after every workday.
- **Before using the detector, refer to [Sensor Poisons and Contaminants](#).**

GasAlertMicroClip XT

Operator's Manual

- **Calibrate the detector before first-time use and then on a regular schedule, depending on use and sensor exposure to poisons and contaminants. BW recommends calibrating at least once every 180 days (6 months).**
- **The combustible sensor is factory calibrated to 50% LEL methane. If monitoring a different combustible gas in the %LEL range, calibrate the sensor using the appropriate gas.**
- **Only the combustible gas detection portion of this instrument has been assessed for performance by CSA International.**
- **Calibrate only in a safe area that is free of hazardous gas and in an atmosphere of 20.9% oxygen.**
- **It is recommended that the combustible sensor be checked with a known concentration of calibration gas after any exposure to contaminants/poisons such as, sulfur compounds, silicon vapors, halogenated compounds, etc.**
- **BW recommends to bump test the sensors before each day's use to confirm their ability to respond to gas by exposing the detector to a gas concentration that exceeds the alarm setpoints. Manually verify that the audible and visual alarms are activated. Calibrate if the readings are not within the specified limits.**

- **Caution: High off-scale readings may indicate an explosive concentration.**
- **Any rapid up scaling reading followed by a declining or erratic reading may indicate a gas concentration beyond the upper scale limit, which can be hazardous.**
- **Extended exposure of the GasAlertMicroClip XT to certain concentrations of combustible gases and air may stress a detector element that can seriously affect its performance. If an alarm occurs due to a high concentration of combustible gases, calibrate the detector. If necessary, replace the sensor.**
- **Protect the combustible sensor from exposure to lead compounds, silicones, and chlorinated hydrocarbons.**
- **Sensor exposure to certain organic vapors (such as leaded gasoline and halogenated hydrocarbons) may temporarily inhibit sensor performance. After exposure, a bump test or calibration is recommended.**
- **For use only in potentially explosive atmospheres where oxygen concentrations do not exceed 20.9% (v/v).**

Parts of the GasAlertMicroClip XT

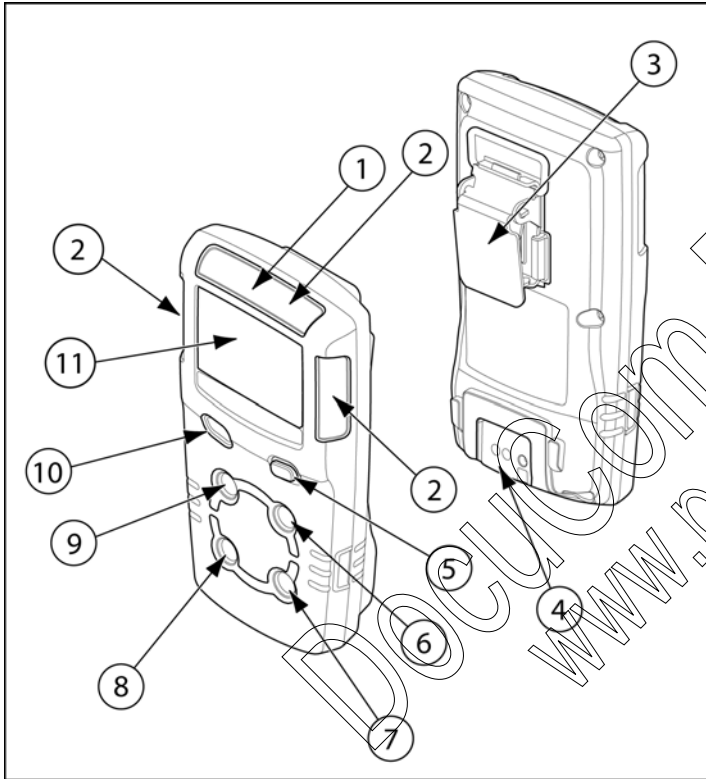

Item	Description
1	IntelliFlash
2	Visual alarm indicators (LEDs)
3	Alligator clip
4	Charging connector / IR interface
5	Pushbutton
6	Carbon monoxide (CO) sensor
7	Hydrogen sulfide (H ₂ S) sensor
8	Oxygen (O ₂) sensor
9	Combustible (LEL) sensor
10	Audible alarm
11	Liquid crystal display (LCD)

Display Elements

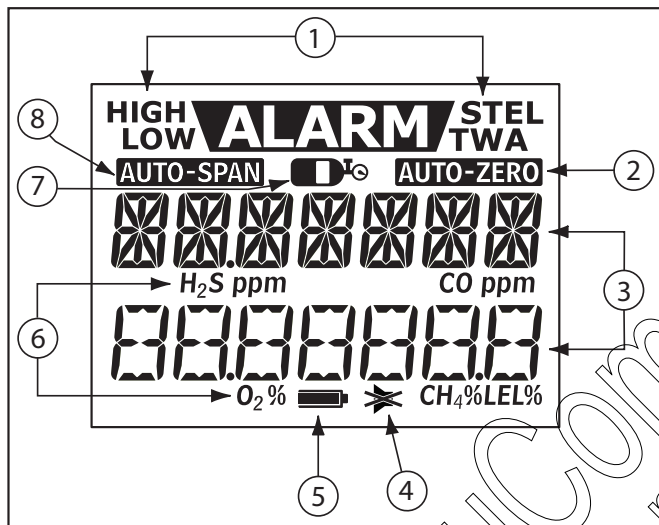

Item	Description
1	Alarm condition
2	Automatically zero sensor
3	Numeric value
4	Stealth mode
5	Battery life indicator
6	Gas identifier bars
7	Gas cylinder
8	Automatically span sensor

Sensor Poisons and Contaminants

Several cleaners, solvents, and lubricants can contaminate and cause permanent damage to sensors. Before using cleaners, solvents, and lubricants in close proximity to the detector sensors, read the following caution and table.

⚠ Caution

Use only the following BW Technologies by Honeywell recommended products and procedures:

- **Use water based cleaners.**
- **Use non-alcohol based cleaners.**
- **Clean the exterior with a soft, damp cloth.**
- **Do not use soaps, polishes, or solvents.**

Below are common products to avoid using around sensors.

Cleaners and Lubricants

- Brake cleaners
- Lubricants
- Rust inhibitors
- Window and glass cleaners
- Dishsoaps
- Citrus based cleaners

- Alcohol based cleaners
- Hand sanitizers
- Anionic detergents
- Methanol (fuels and antifreezes)









Silicones

- Silicone cleaners and protectants
- Silicone based adhesives, sealants, and gels
- Hand/body and medicinal creams containing silicone
- Tissues containing silicone
- Mold releasing agents
- Polishes

Aerosols

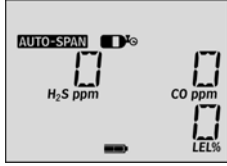
- Bug repellents and sprays
- Lubricants
- Rust inhibitors
- Window cleaners

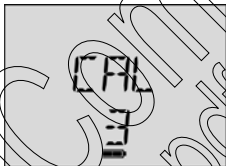
Calibration

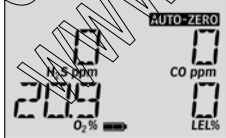
Procedure	Display	Procedure	Display
<p>⚠ Caution</p> <p>Calibrate only in a safe area that is free of hazardous gas in an atmosphere of 20.9% oxygen.</p> <p>1. Press and hold  as the detector performs the OFF countdown. Continue holding  when the LCD briefly deactivates.</p>		<p>4. When  flashes, connect the gas cylinder (refer to page 8) and apply gas at a flow rate of 250-500 ml/min.</p> <p>After a sufficient amount of gas has been detected (approximately 30 seconds), the detector beeps and AUTO-SPAN flashes while the detector completes the calibration.</p>	
<p>2. The LCD then activates again and performs the CAL countdown. Continue holding  until the countdown is complete to enter calibration.</p>		<p>5. The LCD displays CAL DUE. Next, a screen displays showing the number of days remaining before calibration is due for each sensor. The LCD then displays the earliest calibration due date, as some sensors require more frequent calibrations.</p>	
<p>3. AUTO-ZERO flashes while the detector zeroes all of the sensors and calibrates the oxygen sensor. If a sensor fails to auto zero, it cannot be calibrated. When auto zero is complete, the LCD displays APPLY GAS.</p>		<p>Note: Only use the calibration cap during the calibration span process and for bump tests.</p> <p>Wind currents may cause false readings and poor calibrations.</p> <p>Do not calibrate the detector during or immediately after charging is complete.</p>	

Attach the Gas Cylinder to the Detector

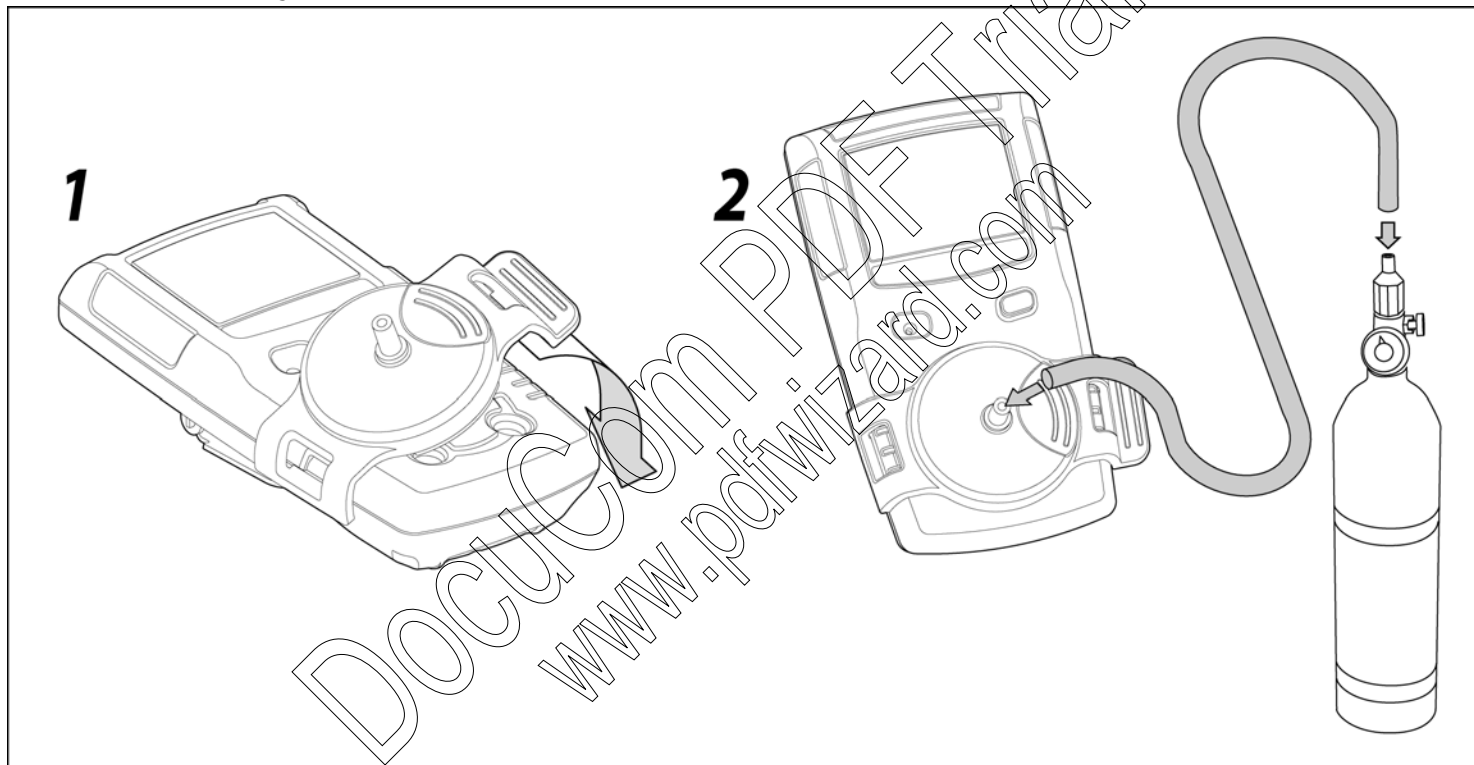

Bump Test

Gas Cylinder Guidelines (Bump Test)

- To ensure an accurate bump check, use a premium-grade gas. Use gases approved by the National Institute of Standards and Technology.
- Do not use a gas cylinder that is past its expiration date.

Gas Cylinder Connection

1. Connect the calibration hose to the 0.5 l/min regulator on the gas cylinder. For use with the MicroDock II, use a demand flow regulator.

NOTE: Cylinders that are used with a demand flow regulator must meet the following maximum inlet pressure specifications:

- Disposable cylinders 0-1000 psig/70 bar
- Refillable cylinders 0-3000 psig/207 bar

To perform an automated bump check, refer to the *MicroDock II User Manual*.

2. Connect the calibration hose to the calibration cap.
3. Attach the calibration cap to the detector.
4. Apply gas. Verify the visual and audible alarms activate.
5. Close the regulator and remove the calibration cap from the detector.
NOTE: The detector will temporarily remain in alarm until the gas clears from the sensors.
6. Disconnect the hose from the calibration cap and the regulator.

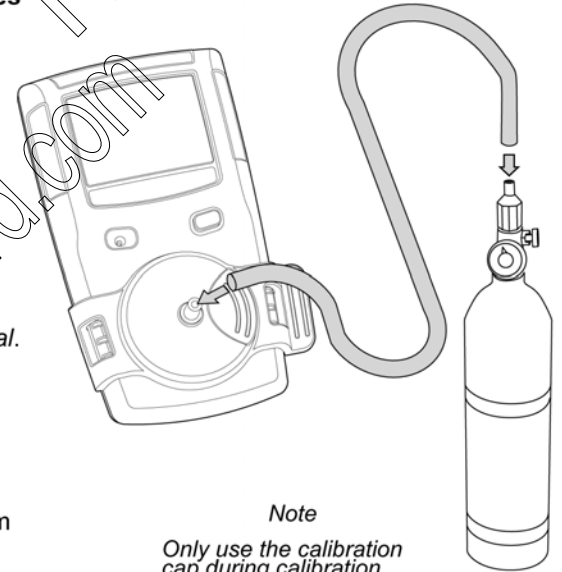





GasAlertMicroClip XT

Operator's Manual

Alarms

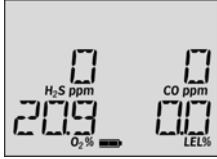
Refer to the following table for information about alarms and corresponding screens. If **Stealth** mode is enabled, the audible and visual alarms are disabled. Only the vibrator alarm activates.

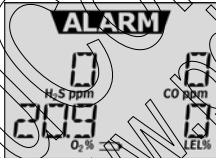
Alarm	Display	Alarm	Display
Low Alarm <ul style="list-style-type: none"> • Slow siren • Slow alternating flash • ALARM and gas bar flash • Vibrator alarm activates 		TWA Alarm <ul style="list-style-type: none"> • Slow siren • Slow alternating flash • ALARM and gas bar flash • Vibrator alarm activates 	
High Alarm <ul style="list-style-type: none"> • Fast siren • Fast alternating flash • ALARM and gas bar flash • Vibrator alarm activates 		STEL Alarm <ul style="list-style-type: none"> • Fast siren • Fast alternating flash • ALARM and gas bar flash • Vibrator alarm activates 	
Multi-Gas Alarm <ul style="list-style-type: none"> • Alternating low and high alarm siren and flash • ALARM and gas bars flash • Vibrator alarm activates 		Over Limit (OL) Alarm <ul style="list-style-type: none"> • Fast siren and alternating flash • ALARM and gas bar flash • Vibrator alarm activates • OL displays 	

Alarm	Display	Alarm	Display
<p>Sensor Alarm</p> <ul style="list-style-type: none"> • During startup Error [sensor name] displays • During normal operation Err displays 		<p>Confidence Beep and IntelliFlash</p> <ul style="list-style-type: none"> • One beep and flash every second <p><i>Note: Confidence Beep and IntelliFlash automatically deactivate during low battery alarm, self-test fail, calibration fail, bump test fail, or an alarm event.</i></p>	
<p>Low Battery Alarm</p> <ul style="list-style-type: none"> • Sequence of 10 rapid sirens and alternating flashes with 7 seconds of silence in between (continues for 15 minutes) •  and ALARM flash, LOW BAT displays, and the vibrator alarm activates • After 15 minutes of the Low Battery alarm, the Automatic Shutdown Alarm sequence begins • OFF displays before deactivating 		<p>Automatic Shutdown Alarm</p> <ul style="list-style-type: none"> • Sequence of 10 rapid sirens and alternating flashes with 1 second of silence in between (sequence reactivates seven times) • LOW BAT and ALARM display, and vibrator alarm activates • OFF displays before deactivating <p><i>Note: Alarms can be set to latching or non-latching. To enable/disable latching, select/deselect Latching Alarms in Fleet Manager II. Local regulations may require a latching alarm.</i></p> <p><i>If Low Alarm Acknowledge is enabled and a low alarm occurs, press <input type="radio"/> to disable the audible alarm. The visual and vibrator alarms remain activated. If the alarm escalates to a high, STEL, or TWA alarm, the audible alarm reactivates.</i></p>	

User Options Menu

To modify the user options, connect the detector to the IR Link adapter and open Fleet Manager II. Refer to the *Fleet Manager II Operator's Manual* for complete instructions.

The following are the available user options:

1. Sensors (H₂S, CO, LEL, and O₂)

- **Sensor Disabled:** Disables the sensor.
- **Calibration Gas (ppm) / (%LEL) / (%O₂):** Defines the calibration gas concentration for each sensor.
- **Calibration Interval (days):** Defines how often a calibration should be performed.
- **Bump Interval (days):** Defines how often a bump test should be performed.
- **Low Alarm (ppm) / (%LEL) / (%O₂):** Defines the low alarm setpoint.
- **High Alarm (ppm) / (%LEL) / (%O₂):** Defines the high alarm setpoint.
- **TWA Alarm (ppm):** Defines the time-weighted average (TWA) alarm setpoint. H₂S and CO sensors only.
- **STEL Alarm (ppm):** Defines the short-term exposure limit (STEL) alarm setpoint. H₂S and CO sensors only.

- **STEL Interval (minutes):** Defines the short-term exposure limit (5-15 minutes). H₂S and CO sensors only.
- **Auto-Zero Startup:** When enabled, the detector automatically zeros the H₂S, CO, and LEL sensors during the startup self-test.
- **LEL By Volume CH₄:** When enabled, the LEL reading is displayed as %vol., assuming a methane environment.
- **O₂ Auto-Calibration on Startup:** When enabled, the O₂ sensor is automatically calibrated during startup.

2. User Options

- **Confidence Beep:** When enabled, the detector beeps once every second to verify the battery has sufficient power to detect hazardous gas and emit an alarm. Detector is shipped with Confidence Beep disabled.
- **Latching Alarms:** When enabled, the audible, visual, and vibrator alarms persist during a high or low alarm until the gas concentration is below the low alarm setpoint and has been acknowledged by pressing .
- **Safe Mode:** When enabled, **SAFE** continuously displays on the LCD when all gas concentrations are normal or below the alarm setpoints.
- **Stealth Mode:** When enabled, the audible alarm, LEDs and backlight are disabled. ➤ displays on the LCD.

- **Low Alarm Acknowledge:** When enabled, the audible alarm can be disabled during a low alarm. The vibrator, LEDs, and LCD remain enabled. For H₂S, CO, and LEL sensors only.
- **Datalog Interval (seconds):** Enter a value (**5-120** seconds) to define how often a datalog is recorded. Datalog interval cannot be defined with configuring the detector with the IR Link.
- **Force Calibration When Overdue:** When enabled, the detector automatically enters calibration during startup for overdue sensors. If the sensors are not calibrated immediately, the detector will deactivate.
- **Cal Lock:** When enabled, the sensors can only be calibrated using an IR device (IR Link with Fleet Manager II or the MicroDock II base station).
- **Force Bump When Overdue:** When enabled, a bump test is required if the sensor has exceeded its bump test interval. If a successful bump test is not performed, the detector will deactivate.
- **IntelliFlash:** When enabled, the green LED flashes to provide continuous visual confirmation that the detector is operating correctly.
IntelliFlash automatically deactivates during a low battery alarm, a self-test fail, a calibration fail, a bump test fail, or during an alarm event. To define how often IntelliFlash occurs (**1-60** seconds), refer to [Confidence Beep](#)

[and IntelliFlash Interval](#). Default setting is 1 second. Detector is shipped with IntelliFlash enabled.

- **Confidence Beep and IntelliFlash Interval:** Enter a value (**1-60** seconds) to define how often IntelliFlash occurs and the detector beeps. IntelliFlash and/or Confidence Beep must be enabled in order to define Confidence Beep and IntelliFlash Interval.
- **Language:** Select the language to display on the LCD: **English**, **Français** (French), **Deutsch** (German), **Español** (Spanish), or **Português** (Portuguese).

Charging the Detector

⚠ Warning

Only the manufacturer can replace the battery. Failure to adhere to this caution can lead to fire and/or explosion.

Charge only in a safe area that is free of hazardous gas and within temperatures of 0°C-45°C (32°F-113°F).

The charging adapter is specific to your region. Use of the charging adapter outside your region will damage the charger and the detector.

Do not calibrate during or immediately after charging.

GasAlertMicroClip XT

Operator's Manual

To charge the battery, complete the following:

1. Deactivate the detector. Insert the charging adapter plug into an AC outlet.
2. Connect the charging adapter to the detector IR interface. Refer to the following illustration.

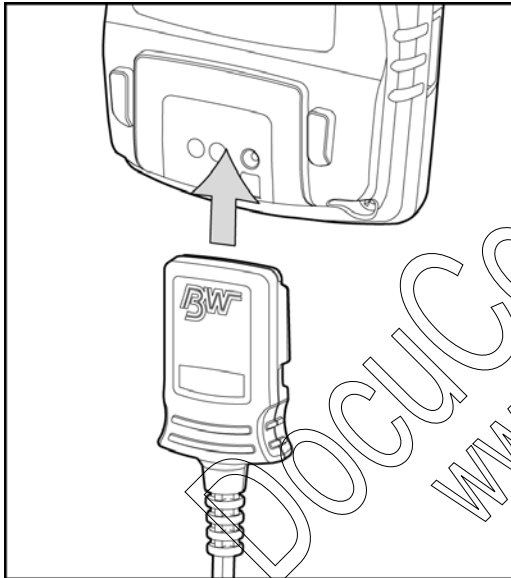

3. Allow the battery to charge for 2-3 hours.
4. To reach full battery capacity, allow the battery to fully charge and discharge three times.
5. Charge the battery after each workday.

Maintenance

To maintain the detector in good operating condition, perform the following basic maintenance as required.

- Calibrate, bump test, and inspect the detector on a regular schedule.
- Maintain an operations log of all maintenance, bump tests, calibrations, and alarm events.
- Clean the exterior with a soft damp cloth. Do not use solvents, soaps, or polishes.

Replacing a Sensor or Sensor Filter

⚠ Warning

To avoid personal injury, use only sensors specifically designed for the detector.

Use proper ESD handling practices.

⚠ Caution

Ensure hands are clean or wear gloves before handling components.

To replace a sensor or sensor filter, refer to the following illustration, table, and procedures.

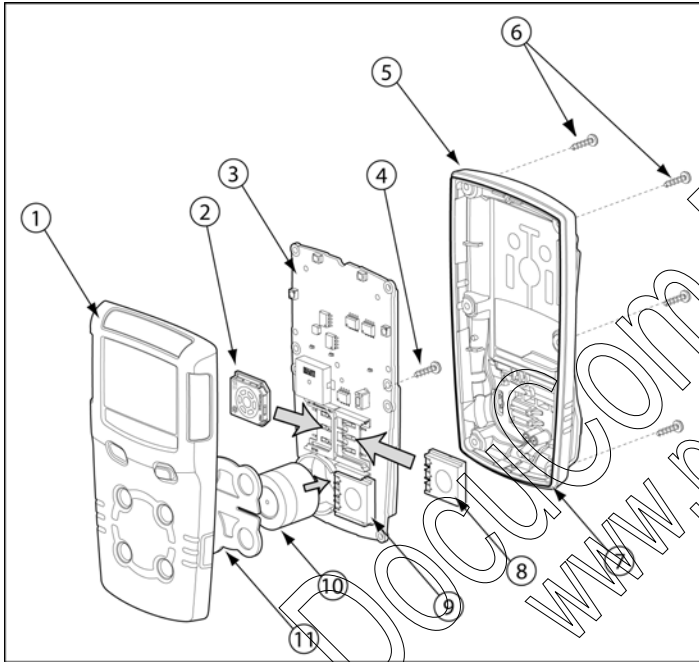

Item	Description
1	Front shell
2	LEL sensor
3	PCB
4	PCB screws (2)
5	Rear shell
6	Machine screws (6)
7	Sealing rib
8	CO sensor
9	H ₂ S sensor
10	O ₂ sensor
11	Sensor filter

1. Deactivate the detector. On a clean surface, place the detector face down.
2. Remove the six machine screws from the rear shell. Remove the back cover by lifting the top and the bottom upwards simultaneously to prevent damaging the charging pins.

Replacing the sensor filter

1. Note the placement of the PCB to ensure it is replaced correctly. Remove the two screws on the PCB. Remove the PCB carefully.

⚠ Caution

Ensure no damage occurs to the battery.

2. Remove the old sensor filter. It may be stuck to the sensors.
3. Place the new sensor filter.

Note

When inserting a new sensor filter, ensure the black gasket is facing the front shell.

4. To complete the detector, refer to [Reassembling the detector](#).

Replacing H₂S, CO, and LEL sensor

1. Note the placement of the PCB to ensure it is replaced correctly. Remove the two screws on the PCB. Remove the PCB carefully.

⚠ Caution

Ensure no damage occurs to the battery.

If the sensor filter is stuck to the sensors, remove and replace the sensor filter into the front shell.

2. Slide the sensors out.

Note

Detectors that are configured for 1, 2, or 3 gases may contain a dummy sensor in one of the four sensor locations.

3. Insert the new sensor(s).
4. To complete the detector, refer to [Reassembling the detector](#).

Replacing the oxygen sensor

Note

Detectors that are configured for 1, 2, or 3 gases may contain a dummy sensor in one of the four sensor locations.

1. Gently remove the circular rigidified flex PCB atop the sensor from the metal sensor posts. Take care not to tear the flex cable.

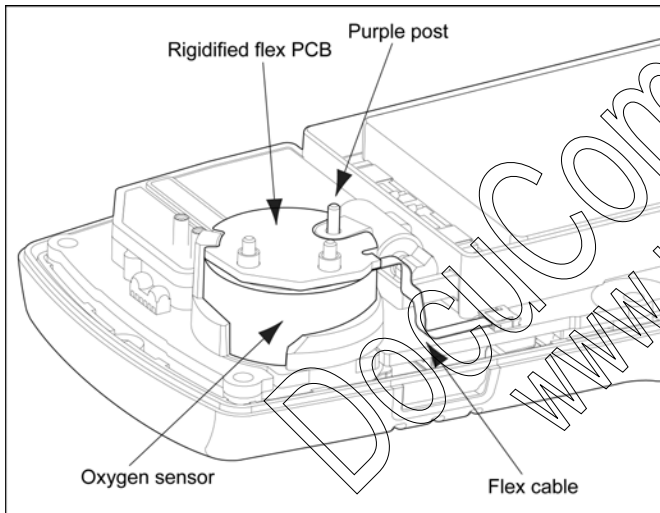

2. Note the placement of the PCB to ensure it is replaced correctly. Remove the two screws on the PCB.

⚠ Caution

Ensure no damage occurs to the battery.

3. Lift the PCB straight up. The oxygen sensor will stay in the front shell. Remove the sensor.
4. On roughly the same spot on the front shell, place the new sensor. Lower the PCB over the oxygen sensor.
5. Ensure the purple plastic sensor post is inserted into the clear plastic hole. Carefully replace the circular rigidified flex PCB atop the metal sensor posts. Take care not to tear the flex cable.
6. Press down to secure the circular rigidified flex PCB atop the metal sensor posts.
7. To complete the detector, refer to [Reassembling the detector](#).

Reassembling the detector

- Verify the PCB is seated correctly and inserted exactly as it was removed (sensors face the front shell). Replace the two PCB screws.

GasAlertMicroClip XT

Operator's Manual

- Visually inspect the battery to ensure no damage has occurred.
- When replacing the rear shell, ensure the charging pins (bottom of inside rear shell) are aligned with the corresponding holes on the PCB.
- Press the front and rear shells together firmly to ensure a proper seal. Ensure the front and rear shell have a uniform, tight 1/16 in. (1 mm) seal on all sides of the detector.
- When replacing the screws, they must be seated properly to prevent cross threading. Turn the screw counter-clockwise until a click is heard and then begin tightening the screw clockwise.

Note

Ensure the rib on the interior rear shell inserts between the battery and the PCB. Refer to the following illustration.

- New sensor(s) should be calibrated. Activate the detector and calibrate the sensor(s). Refer to [Calibration](#).

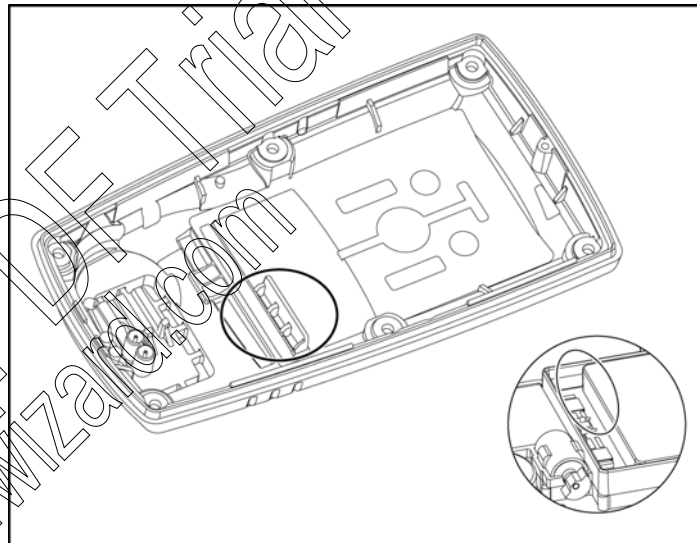

Specifications

Instrument dimensions: 11.25 x 6.00 x 2.89 cm
(4.4 x 2.4 x 1.1 in.)

Weight: 170 g (6.0 oz.)

Operating temperature: -20°C to +58°C (-4°F to +136°F),
+50°C to +58°C is certified by CSA International on the
combustible sensor with ±5% accuracy

Storage temperature: -40°C to +50°C (-40°F to +122°F)

Operating humidity: 0% to 95% relative humidity (non-con-
densing)

Alarm setpoints: May vary by region and are user defined. All
setpoints automatically display during the startup self-test.

Detection range:

H₂S: 0 - 100 ppm (1 / 0.1 ppm increments)

CO: 0 - 500 ppm (1 ppm increments)

O₂: 0 - 30.0% vol. (0.1% vol. increments)

Combustible (LEL): 0 - 100% (1% LEL increments) or
0 - 5.0% v/v methane

Sensor type:

H₂S, CO, O₂: Single plug-in electrochemical cell

Combustibles: Plug-in catalytic bead

O₂ measuring principle: Capillary controlled concentration
sensor

Alarm conditions: TWA alarm, STEL alarm, low alarm, high
alarm, multi-gas alarm, over limit (OL) alarm, low battery alarm,
confidence beep, automatic shutdown alarm

Audible alarm: 95 dB at 30 cm (1 ft.) (100 dB typical) variable
pulsed beeper

Visual alarm: Red light-emitting diodes (LED)

Display: Alphanumeric liquid crystal display (LCD)

Backlight: Activates for 5 seconds when the pushbutton is
pressed and during an alarm condition

Self-test: Initiated during activation

Calibration: Automatic zero and automatic span

Oxygen sensor: Automatic span on activation (enable/disable)

User field options: Startup message, confidence beep, latch-
ing alarms, enable/disable safe display mode, oxygen mea-
surement, combustible sensor measurement, sensor disable,
define calibration interval, force calibration, calibration lock,
force bump, define bump interval, bump due lock, stealth mode,
language selection, enable/disable automatic oxygen calibra-
tion, enable/disable auto zero at startup, define alarm setpoints,
define span concentration values, define STEL calculation

GasAlertMicroClip XT

Operator's Manual

period, low alarm acknowledge, IntelliFlash, confidence beep, and IntelliFlash interval

Battery operating time: 1 rechargeable lithium polymer battery 10 hours (typical)

Year of manufacture: The detector's year of manufacture is determined from the serial number. The second and third number after the first letter determines the year of manufacture. E.g., KA4**10**-001000 = 2010 year of manufacture

Approved batteries:

Approved batteries for GasAlertMicroClip XT:
Narada NL 503759 and BYD Type SL503759

Rechargeable battery

Lithium polymer $-20^{\circ}\text{C} \leq T_a \leq +50^{\circ}\text{C}$

Temperature code

T4

Battery charger: GasAlertMicroClip XT charging adapter

First-time charge: 2-3 hours

Normal charge: 2-3 hours

Warranty: 2 years including sensors

Approvals:

Approved by CSA to both U.S. and Canadian Standards
CAN/CSA C22.2 No. 157 and C22.2 152
ANS/UL - 913 and ANSI/ISA - S12.13 Part 1

CSA Class I, Division 1, Group A, B, C, and D

ATEX CE 0539 Ex II 1 G Ex ia IIC T4 Ga
KEMA 06ATEX0056
EN 60079-0, EN 60079-11, and EN 60079-26

IECEx Ex ia IIC T4 Ga IECEx CSA 05.0015
IEC 60079-0, IEC 60079-11, IEC 60079-26

This equipment has been tested and found to comply with the limits for a Class B digital device, pursuant to Part 15 of the FCC Rules and ICES-003 Canadian EMI requirements. These limits are designed to provide reasonable protection against harmful interference in a residential installation. This equipment generates, uses and can radiate radio frequency energy and, if not installed and used in accordance with the instructions, may cause harmful interference to radio communications. However, there is no guarantee that interference will not occur in a particular installation. If this equipment does cause harmful interference to radio or television reception, which can be determined by turning the equipment off and on, the user is encouraged to try to correct the interference by one or more of the following measures:

- Reorient or relocate the receiving antenna.
- Increase the separation between the equipment and receiver.
- Connect the equipment into an outlet on a circuit different from that to which the receiver is connected.
- Consult the dealer or an experienced radio/TV technician for help.

DocuCom PDF Trial
www.pdfwizard.com

Wear yellow. Work safe.

iERP: 131474-L3

D6567/0 [English]

© BW Technologies 2010. All rights reserved.