

## Using the Low-Pressure Insertion Mechanism

The *Low-Pressure* insertion mechanism is shipped pre-assembled and with the transducer already properly aligned. The mechanism includes the following three components in addition to the transducer (see Figure 3-1 below):

- junction box
- barrel
- packing gland

In addition to the insertion mechanism itself, the user will need to provide the following items for use during the installation:

- packing tool
- gasket to place on the isolation valve
- straightedge or ruler
- tag to place on the isolation valve
- bolts, nuts and washers for flanges

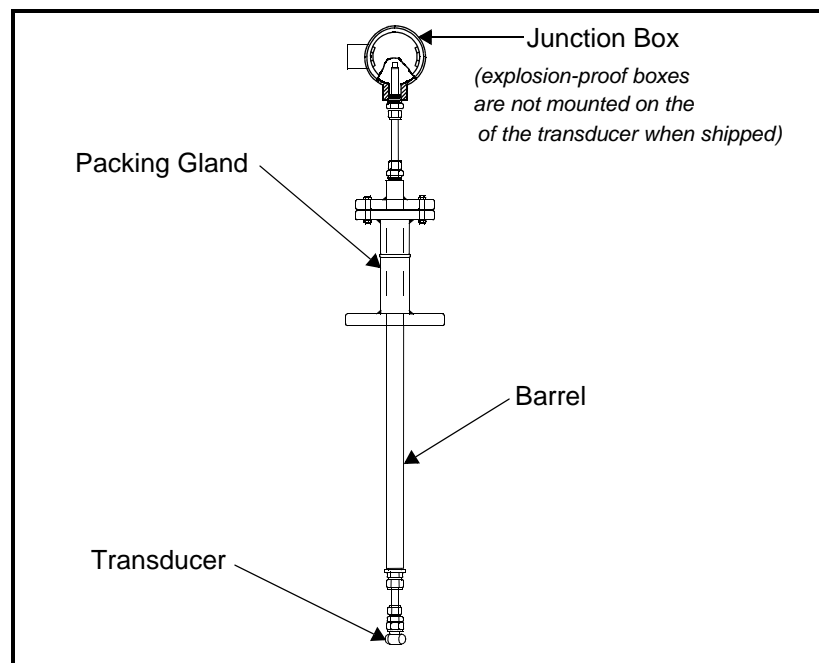

Figure 3-1: A Low-Pressure Insertion Mechanism

## Installing the Insertion Mechanism

Before you begin the installation, you should try to find an area where you can place the insertion mechanism upright without putting any weight on the transducer. A bench with a cutout large enough to slide the transducer through would be an ideal location.

---

### Caution!

The manual insertion mechanisms are designed for low-pressure applications of 80 psig (5.5 bar) or less. Use all appropriate safety precautions when inserting or withdrawing the insertion mechanism from the process line.

---

1. After unpacking the insertion mechanism, visually inspect the transducer for damage. Make sure the Swagelok fitting at the top of the transducer has not come loose.

**IMPORTANT:** *The stop ring at the end of the barrel should be loose. DO NOT tighten this Swagelok fitting or you could alter the transducer alignment.*

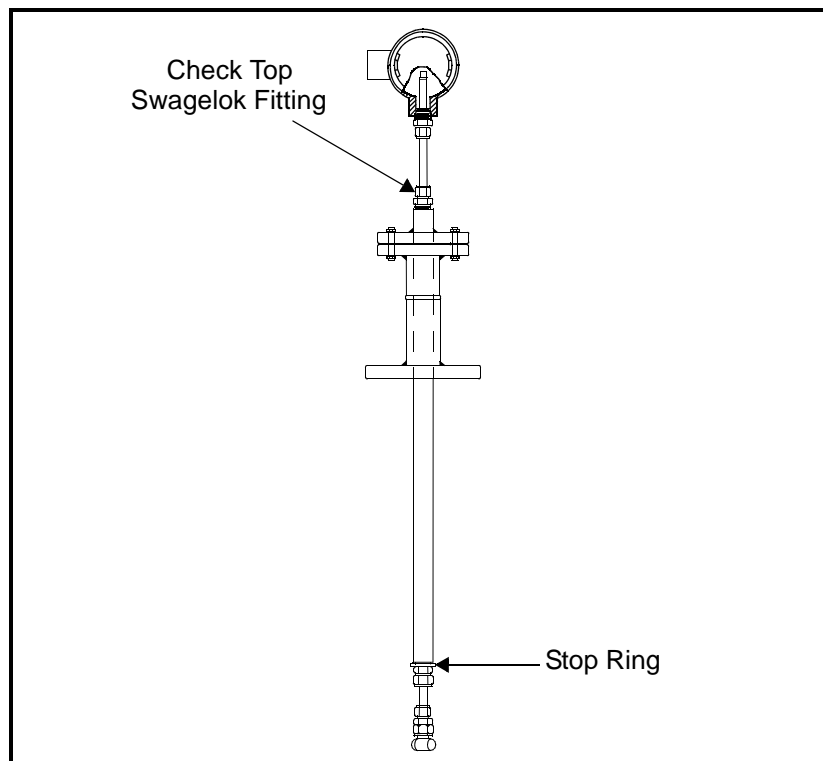

Installing the Insertion Mechanism (cont.)

2. Remove the four bolts that fasten the barrel to the packing gland.

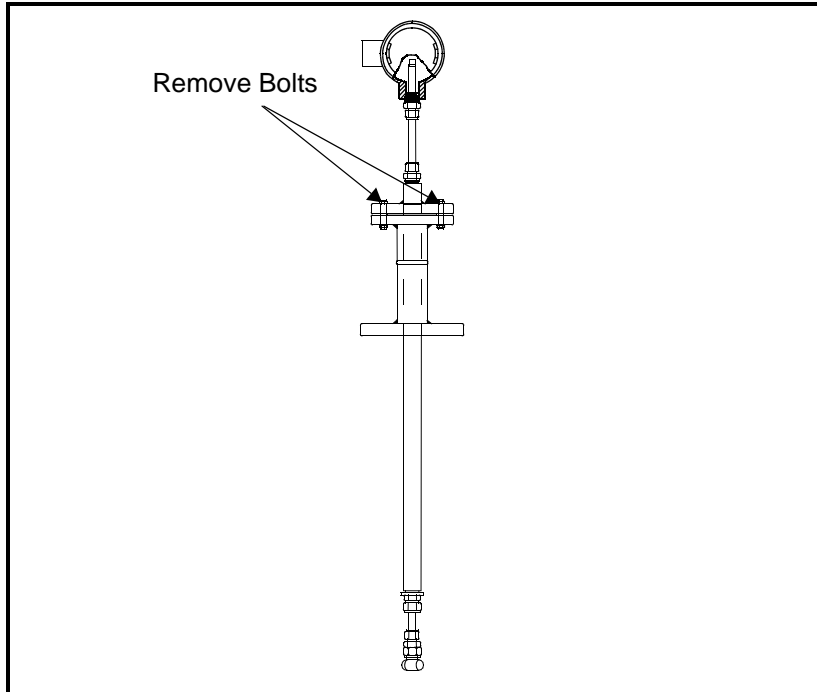

3. Retract the barrel from the packing gland so that the transducer head is recessed in the packing gland. You will hear the stop ring click when the transducer is fully recessed.

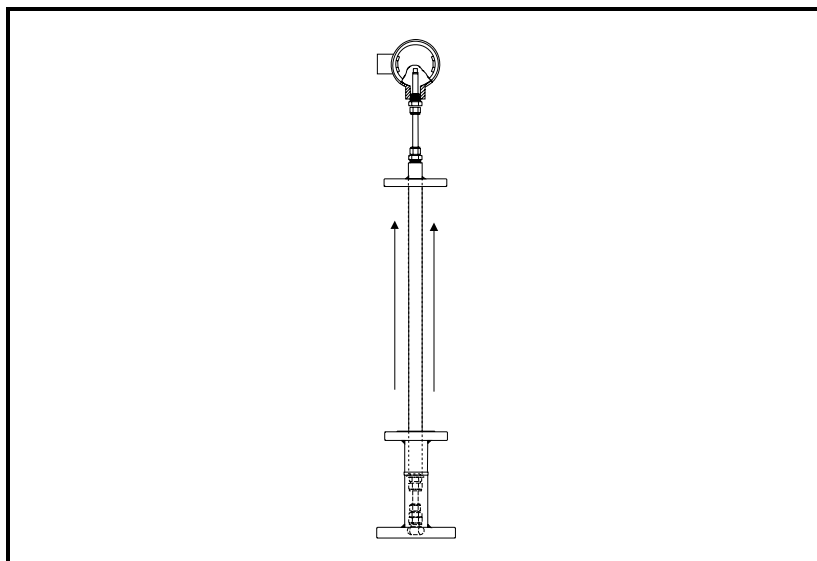

Installing the Insertion  
Mechanism (cont.)

4. Visually inspect the mechanism to make sure the transducer is recessed in the packing gland. Then, recheck the mechanism to make sure the top Swagelok fitting is still tight.
5. Lift the gasket and insert the packing tool into the packing nut. Turning the packing tool clockwise to tighten the packing material until the barrel remains in position without support.

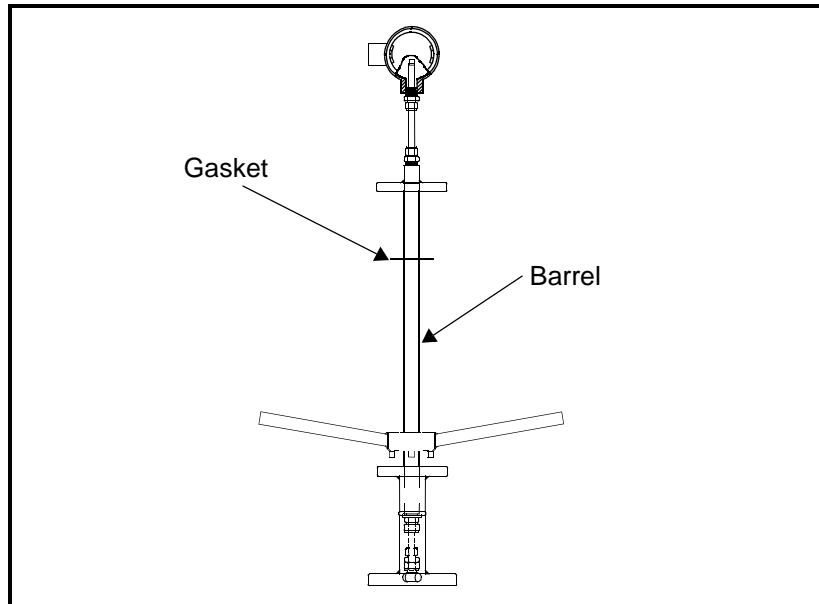

6. Place a gasket on the isolation valve.

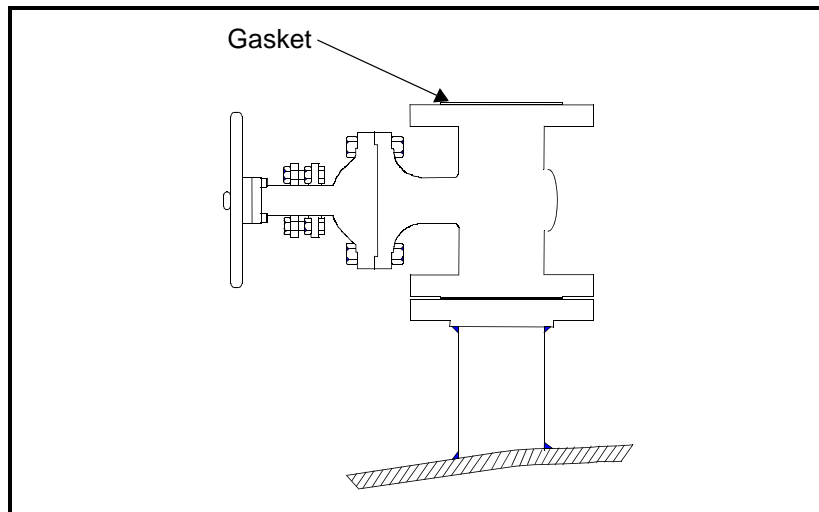

Installing the Insertion Mechanism (cont.)

7. Grasp the insertion mechanism by the barrel and place the insertion mechanism on the isolation valve.

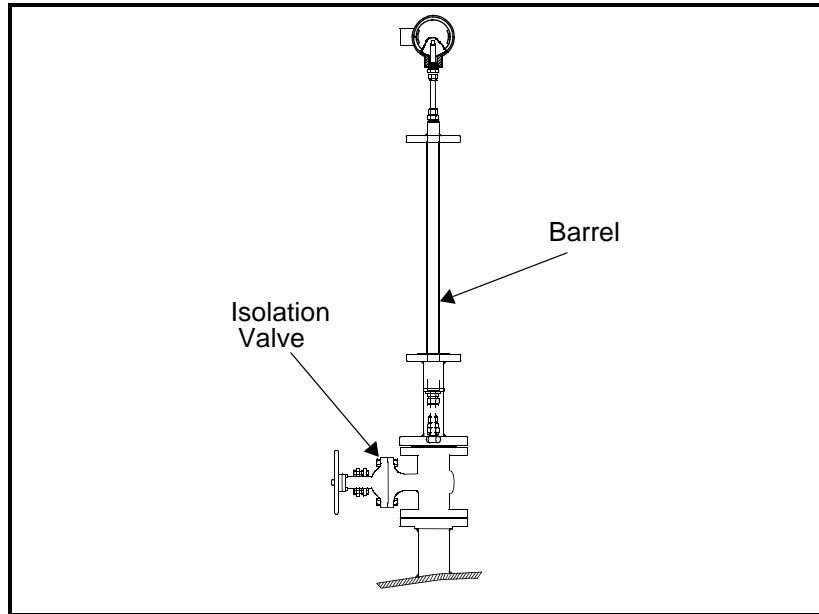

8. Line up the holes in the two flanges and bolt the packing gland to the isolation valve.

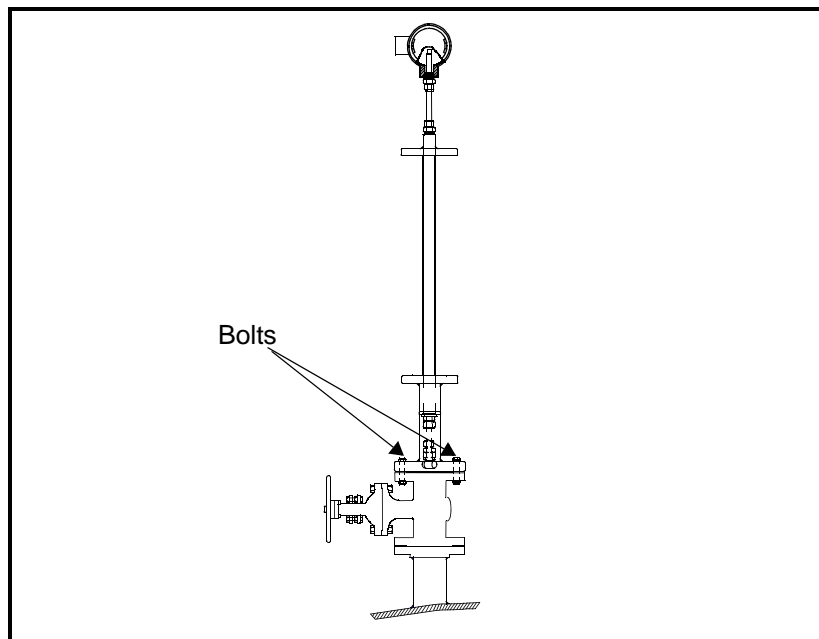

Installing the Insertion  
Mechanism (cont.)

9. Using the packing tool, tighten the packing nut until the nut is recessed.

**IMPORTANT:** *The packing material must be securely packed before the isolation valve is opened.*

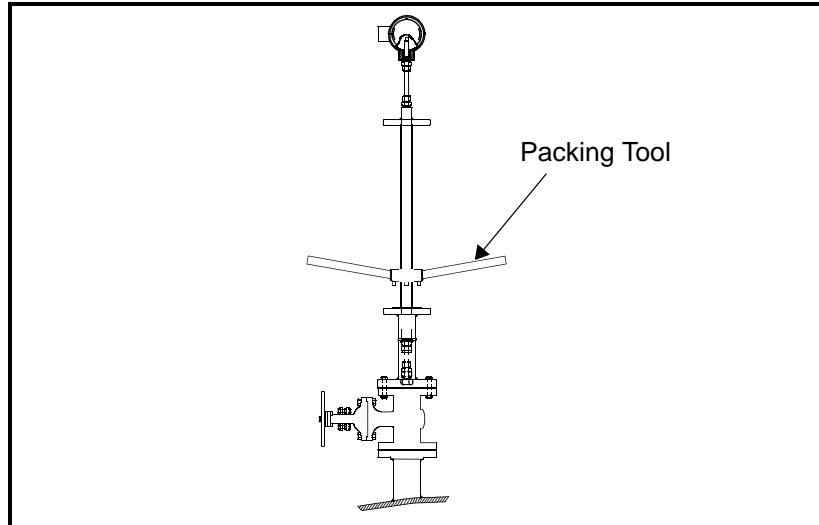

Before opening the isolation valve, carefully check the following:

- the barrel is pulled up as far as possible
- all flange bolts are secure
- the packing nut is recessed

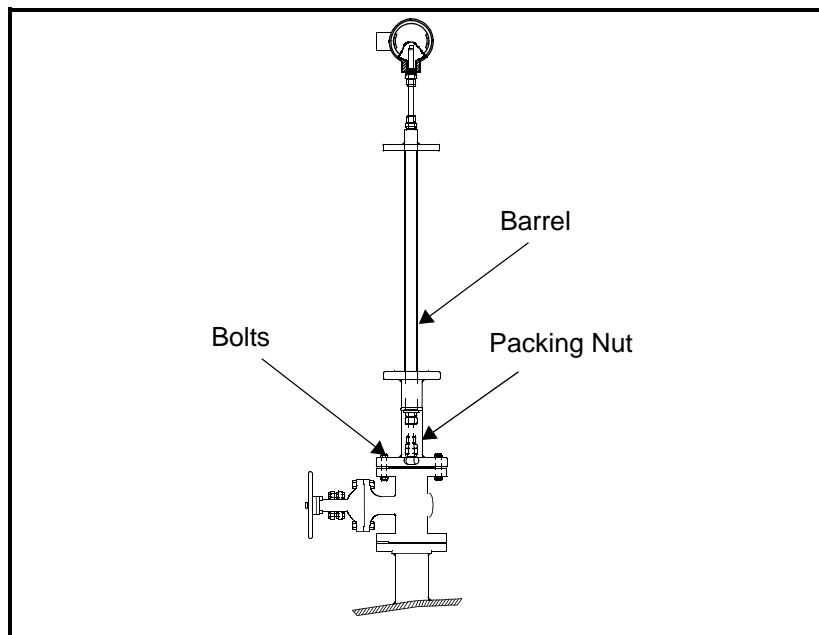

Inserting the Transducer into the Pipe

---

**!WARNING!**  
Follow all applicable safety codes and practices before opening the isolation valve.

---

1. Open the isolation valve.
2. Place your hands on top of the barrel and push the barrel/transducer assembly down into the pipe so that the barrel flange and the packing gland flange meet.

**Note:** *Due to friction in the packing gland, you may have to twist the barrel to start the assembly moving.*

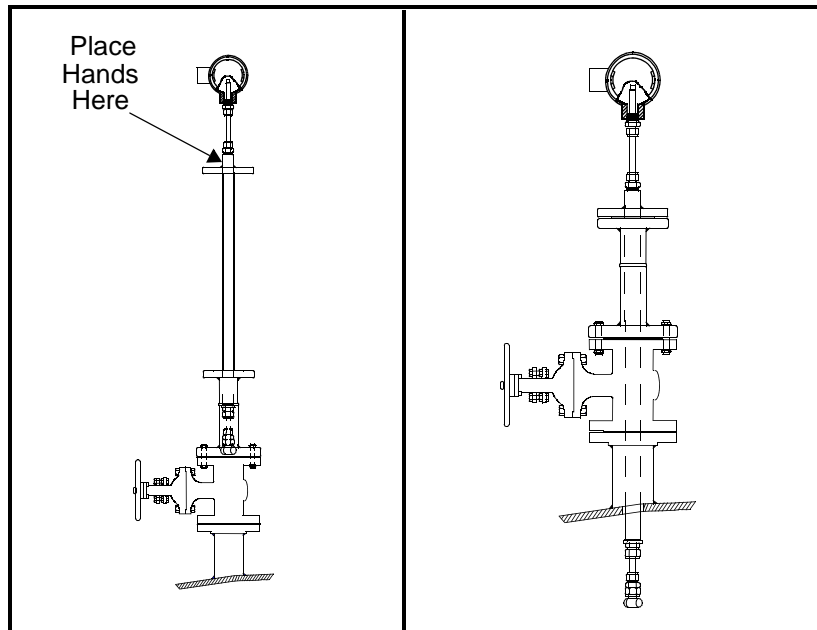

### Inserting the Transducer into the Pipe (cont.)

- If you have a Bias 90° configuration, orient the alignment marks on each barrel flange so that they are facing each other. An alignment mark is scribed on both the top and the side of each flange and the marks are highlighted with paint.

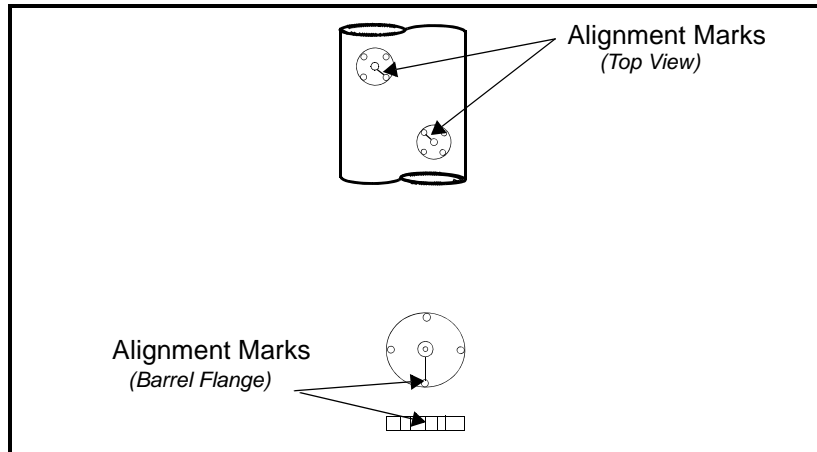

- Insert two bolts into the flanges and hand tighten the nuts.

**IMPORTANT:** *Do not insert the remaining bolts into the flanges until instructed to do so in the following section.*

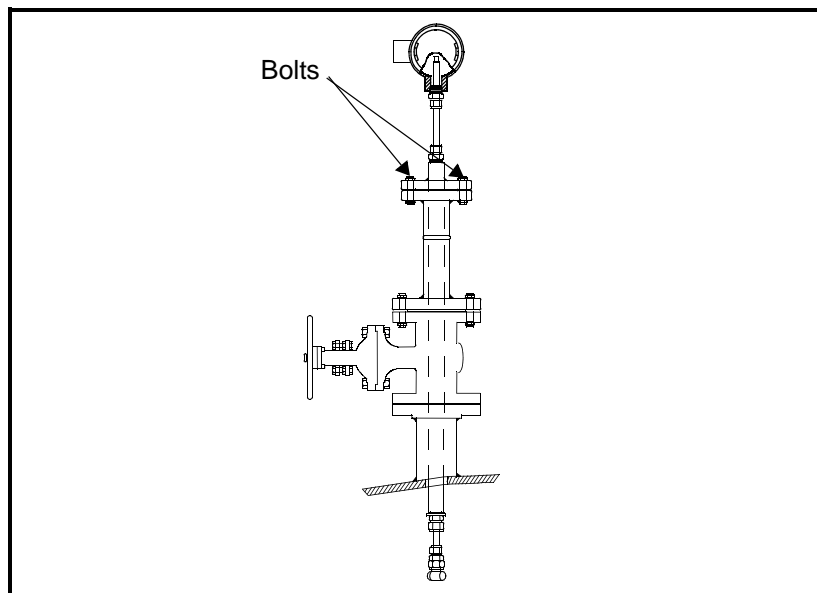

- Install the second insertion mechanism by repeating the procedures used to install the first insertion mechanism.

Aligning the Transducers

To align the transducers, complete the following steps:

1. Use a straightedge to orient the alignment marks so they are exactly facing each other.
2. Insert the remaining bolts into the flanges and tighten the nuts securely.
3. Place a tag on each isolation valve stating the following:

---

**Caution!**

Do not operate (CLOSE) this valve while the transducer is inserted into the pipe.

---