

GE
Sensing & Inspection Technologies

Druck DPI 142

Precision Barometer

User Manual - K0343

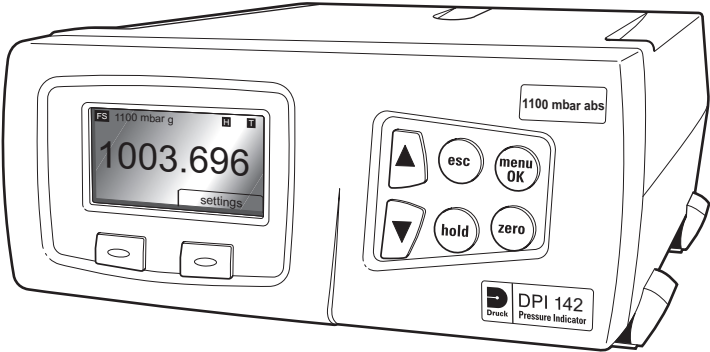

Approved Service Agents

www.gesensinginspection.com

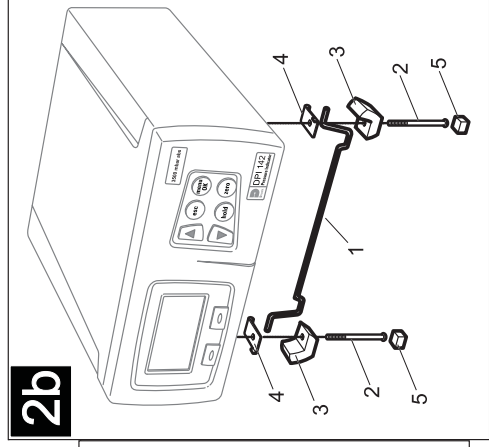
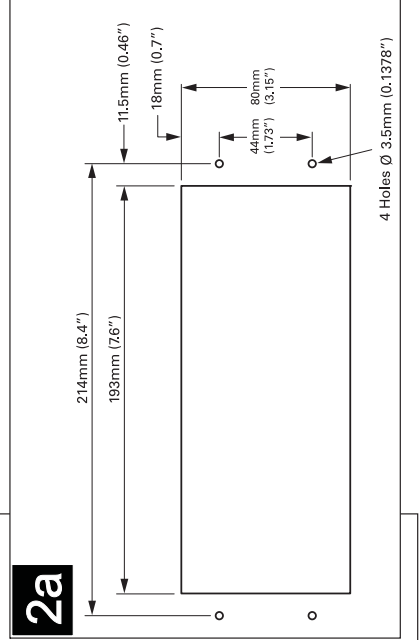
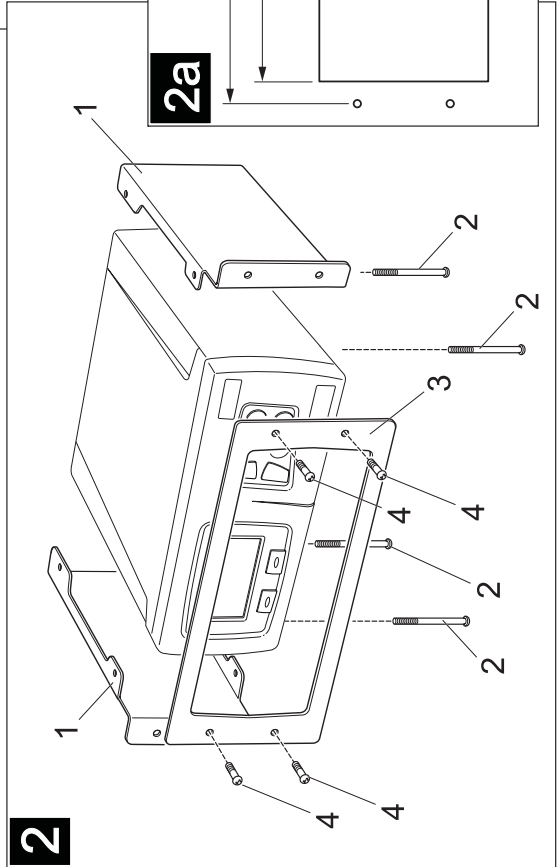
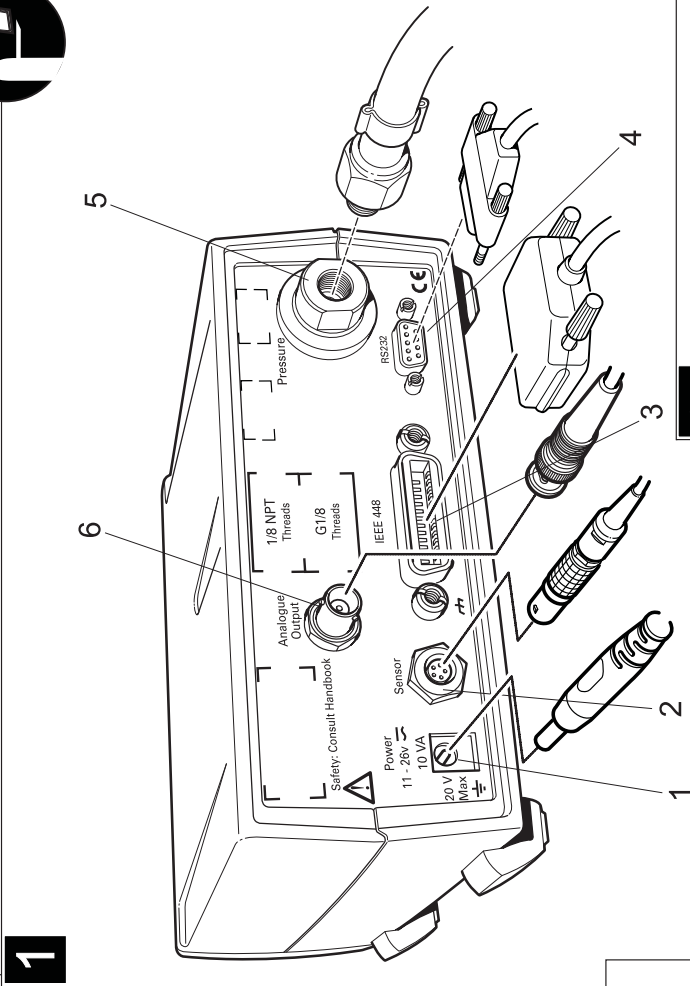
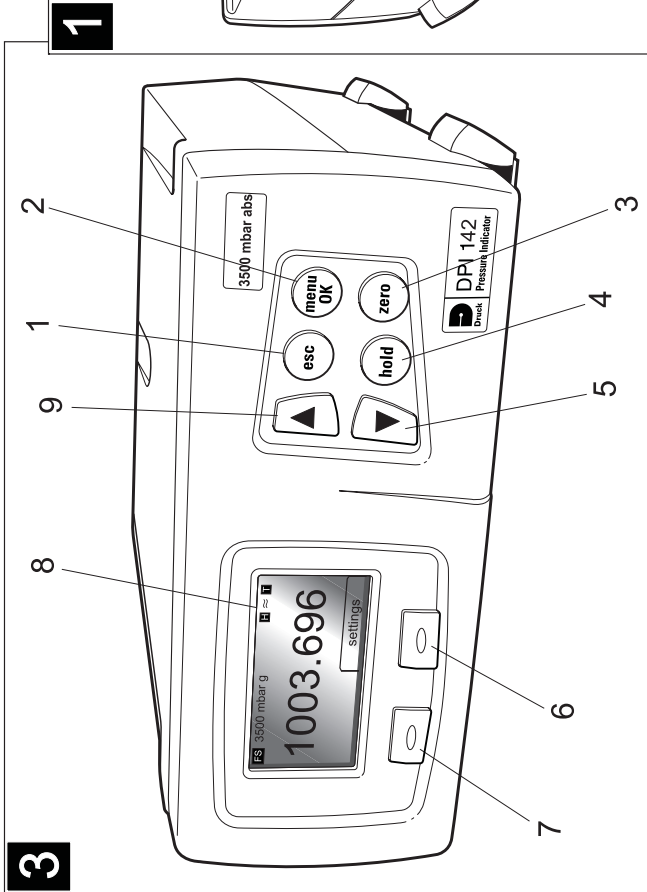

General Introduction

This manual provides operating instructions for the DPI 142 Precision Barometer compatible with the requirements of operating the instrument.

Safety

The manufacturer has designed this equipment to be safe when operated using the procedures detailed in this manual. The user must not use this equipment for any other purpose than that stated.

This manual contains safety and operating instructions that must be followed to make sure of safe operation and to keep the equipment in a safe condition. The safety instructions are either warnings or cautions issued to protect the user and the equipment from injury or damage. Use suitably qualified personnel and good engineering practice for all procedures in this manual.

Pressure

Do not apply pressure greater than the maximum safe working pressure stated in the specification.

Technical advice

For technical advice contact the manufacturer or subsidiary.

Symbols

The following symbols mark this equipment:



Refer to the manual.



Read this manual before operating the instrument.



This product meets the essential requirements of the relevant EC directives.



Do not dispose of this product as household waste.

Druck DPI 142 User Manual

ABBREVIATIONS

The following abbreviations are used in this publication.

Note: *Abbreviations are the same in the singular and plural.*

abs	absolute	MWP	maximum working pressure
°C	degrees Celsius	mbar	millibar
DPI	digital pressure indicator (GE product)	mm	millimetre
EMC	electro-magnetic compatibility	mmH ₂ O	millimetres of water
esc	escape	NPT	National Pipe Thread
°F	degrees Fahrenheit	PIN	personal identification number
g	gauge	psi	pounds per square inch
inHg	inches of mercury	QFE	barometric pressure at airfield level
IEEE	institute of electrical and electronic	QFF	calculated barometric pressure at sea level
488	engineers standard 488 data		including air temperature
kg	kilogram	QNH	calculated barometric pressure at sea level
kts	knots	Ref.	reference
lbs	pounds	RS232	serial interface communication standard
LVD	low voltage directive	SCPI	standard commands for programmable instruments
m	metre	(s)	seconds

CONTENTS

Title	page
Approved service agents	inside front cover
Introduction	1
Specification	1
Installation	2
Packaging List	2
Connections	2
Analogue Output Option	3
Panel mounting	3
Bench stand	4
Operation	5
Barometer	6
Barometer settings	7
Height reference	8
User set-up	9
Barograph	10
Altitude	11
Pressure leak test	12
Supervisor set-up	13
Communication Option	14
Analogue Output Option	15

Associated publications

The following e-documents can be downloaded from www.gesensinginspection.com.

SCPI Communications Manual	K0381
Calibration Instructions	K0382

Introduction

The Druck DPI 142 precision, barometric pressure indicator uses a silicon resonant pressure transducer to produce pressure readings in units of pressure measurement and aeronautical units.

The instrument is contained in a moulded plastic case with integral rubber feet for workbench surface use. Function keys, on the front panel, allows the user to access an operating menu and set-up menu. Two more menus supervisor and calibration allow the user to change the PIN codes, communications settings, display language and for calibration of the pressure sensor. A four digit PIN code protects both these facilities. The electrical and pressure connections are located on the rear panel.

The instrument is supplied, as standard, with a RS232 data interface. Options available include an IEEE 488 interface, an optional analogue output, negative calibration, external sensor and panel mount kit.

Specification

Conformity

Safety EN 61010

EMC emission EN 61326-1

EMC immunity EN 61326-1

Certification CE marked

Pressure ranges (absolute)

barometric 750 to 1150 mbar

..... 35 to 1310 mbar, 35 to 2620 mbar, 35 to 3500 mbar

resolution 0.001 mbar

MWP 4000 mbar

Precision

(includes non-linearity, hysteresis, repeatability and temperature effects between 10°C and 40°C

..... 0.01% full-scale

Stability 0.01% full-scale/year

Environmental

Temperature

Operating 5° to 50°C (41° to 122°F)

Storage -20° to 60°C (-4° to 140°F)

Humidity complies with Def. Stan. 66-31 8.6 cat 3

Vibration complies with Def. Stan. 66-31 8.4 cat 4

Shock mechanical shock conforms to EN 61010

Pressure connections (female): G1/8 or 1/8 NPT

Weight (approximate): 1 kg (2.2lbs)

Dimensions

Length 195 mm (7.7")

Width 185 mm (7.2")

Depth 75 mm (3.0")

Druck DPI 142 User Manual

Analogue Option Electrical Specification

Isolated Voltage Output:-

Output Impedance..... 5 Ohm

Maximum Load Capacitance..... 10 nF

Isolated Current Output:-

Maximum Load Impedance..... 900 Ohm

Maximum Load Capacitance..... 10 nF

Accuracy

(including pressure measurement uncertainty)

All voltage and current ranges ± 0.05 % FS (18° to 28°C, 12 months)

Update rate 30 updates per second

Installation

Key to **1**

- | | |
|-----------------------------|--------------------------------------|
| 1 power supply | 4 RS232 connector |
| 2 external sensor connector | 5 G1/8 or 1/8 NPT pressure connector |
| 3 IEEE 488 | 6 analogue output connector |

Packaging List - DPI 142

- i) DPI 142 Precision, Barometric Pressure Indicator.
- ii) Power supply 191-363.
- iii) User manual (this document).
- iv) Pressure indicator calibration certificate.
- vi) Cable, RS232.

Connections

Note: *Switch off the power supply before connecting or disconnecting the instrument. Isolate the pneumatic pressures and depressurise the pipes before connecting or disconnecting the instrument.*

1. Use an appropriate sealing method for all pressure connections.
2. Before use, make sure the SELV power adaptor supplied with the instrument is correct for the power supply voltage. The Safety Extra Low Voltage (SELV) power adaptor complies with EN61010 (including safety requirements for laboratory instruments).

Note: *The instrument can be powered from other AC or DC power supplies in the range 11 to 26 Volts. It is the user's responsibility to make sure the power supply is safe.*

3. Connect the power adaptor to the instrument and switch the power supply on.

Analogue Output Option

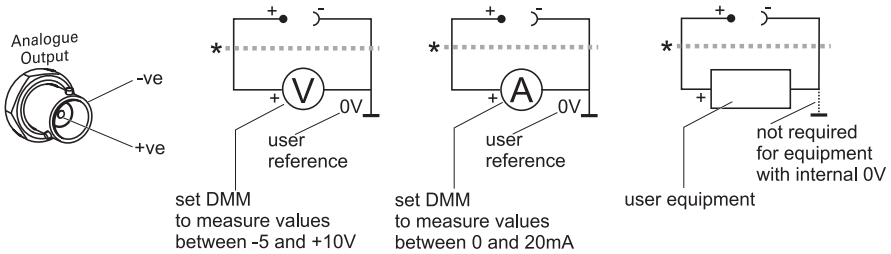

* If necessary, use ferrite ring and twist pair wiring to reduce electrical interference.

Example ferrite ring:

RS Components part numbers

7427114

7427122

74270095

Panel mounting **2** and **2a**

A panel mounted instrument must have the rubber feet removed for the side plates to be secured. The instrument fits into a panel cut-out the side and front plates secure the instrument to the panel. It is important that a panel mount installation provides enough circulation of air to cool the instrument.

Key to **2**

- 1 side plate
- 2 front plate
- 3 screw 3.5mm

Procedure **2**

To fit this option requires a panel cut-out of the dimensions shown in **2a**.

1. Remove the rubber inserts in the feet of the instrument.
2. Unscrew and remove two 45mm screws (2) attaching two feet on one side of the instrument casing. Retain the two 45mm screws for the next step.
3. Fit the side plate (1) to the side of the instrument casing and secure with the two 45mm screws.
4. Repeat steps 2 and 3 for the other side plate.
5. Locate the assembled instrument behind the cut-out panel and align the four 3.5mm holes in the panel and the holes in the flanges of the side plates (1).
6. Locate the front plate (3) over the front of the protruding instrument and secure the front plate with the four screws (4).

Bench stand **2b**

A bench stand lifts the front of the instrument providing a better angle of display and key-pad access for the user.

Key to **2b**

- 1 stand
- 2 screw 45 mm
- 3 foot
- 4 clip (left and right)
- 5 insert, rubber

Operation

Key to **3**



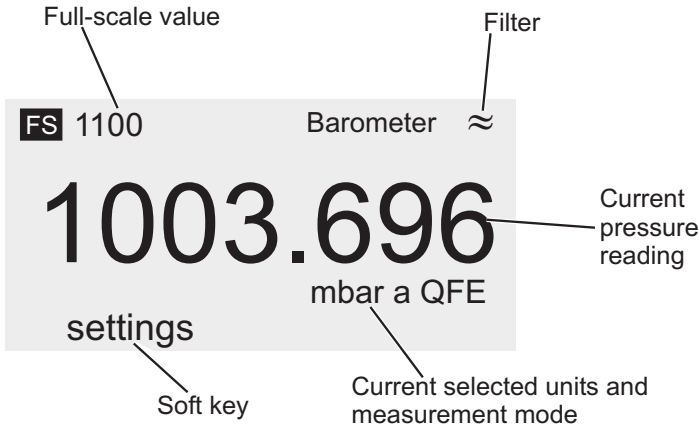

- | | | | |
|---|----------------------|---|--------------------|
| 1 | esc key | 6 | soft key right |
| 2 | menu OK key | 7 | soft key left |
| 3 | zero key | 8 | display |
| 4 | hold key | 9 | up or increase key |
| 5 | down or decrease key | | |



Front panel keys

Key

Function and Comments

-  Steps back one selection without changing setting.
-  Steps back one selection sets and saves value. Selects and enters menu.
-  Moves cursor up and down screen. Increases and decreases value of selected digit.
-  Freezes displayed value, the instrument continues measuring but does not display measured value until key pressed again.
-  Changes displayed value to 0.000 stores difference (offset) in volatile memory.

Barometer

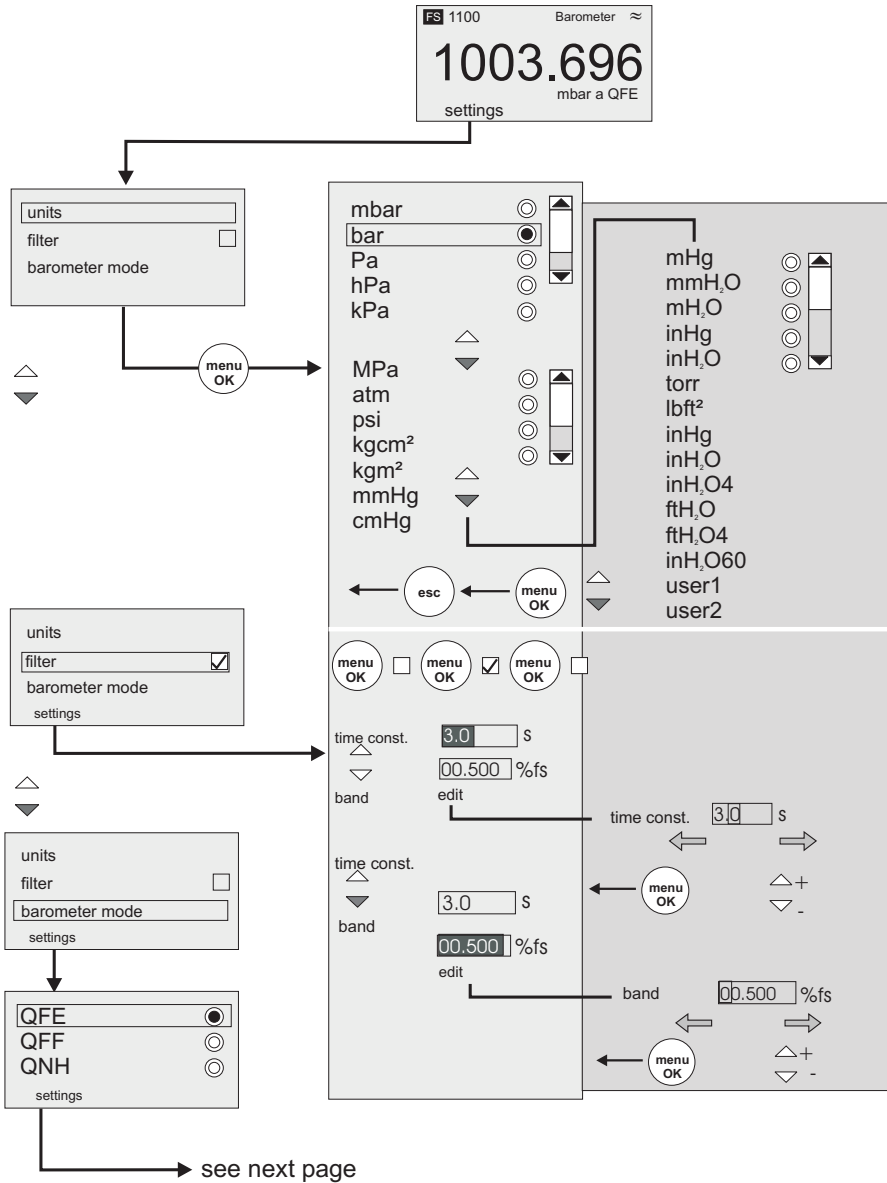

Barometer settings

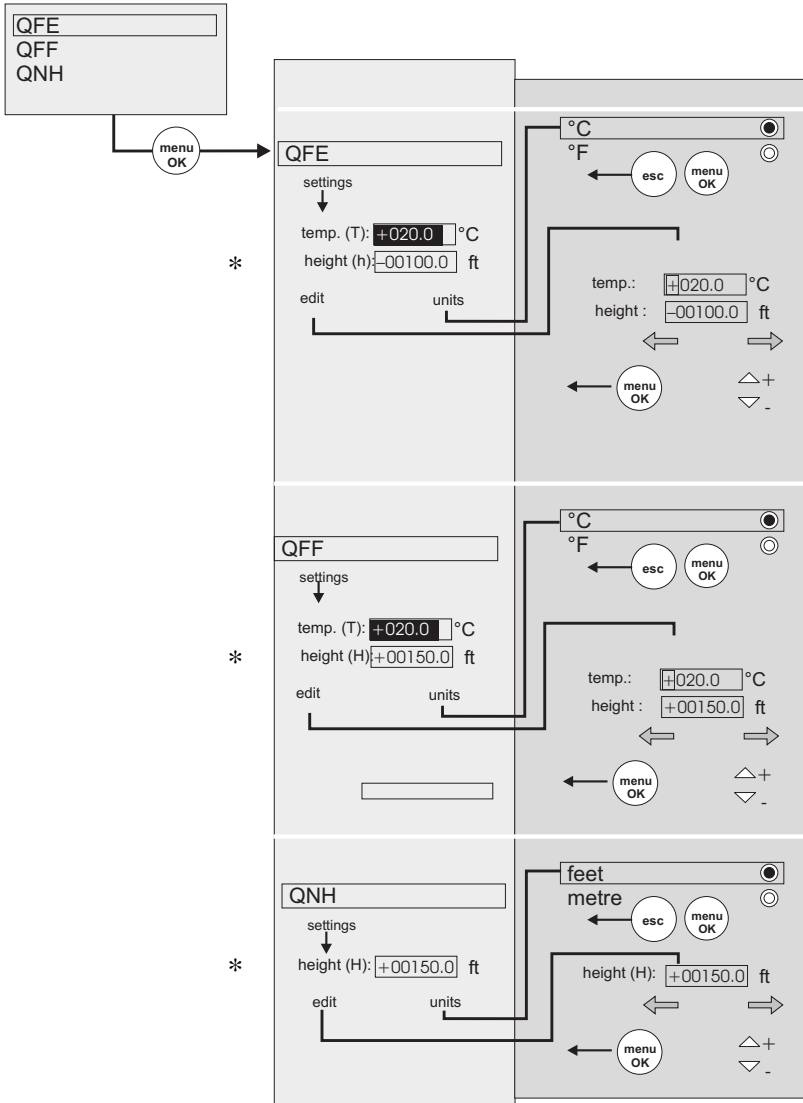

* See next page - "Height reference".

Height reference

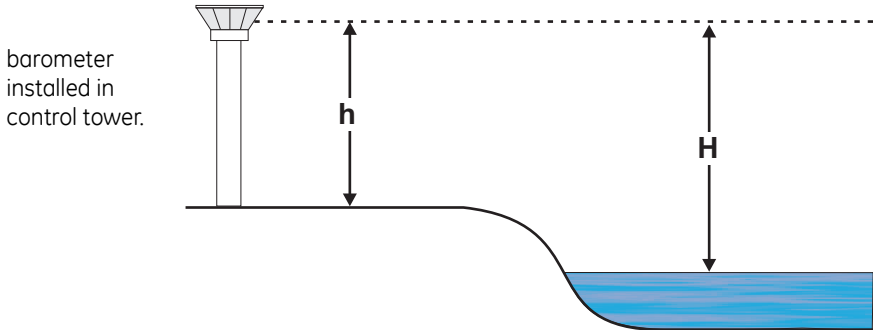

- h** height from the barometer installation to the reference point (for example: the runway).
Note: *h is negative if the reference point is below the barometer installation.*
- H** height of the barometer installation above or below standard sea level datum - mean sea level.
Note: *H is negative if the barometer installation is below the standard sea level datum.*

User Set-up

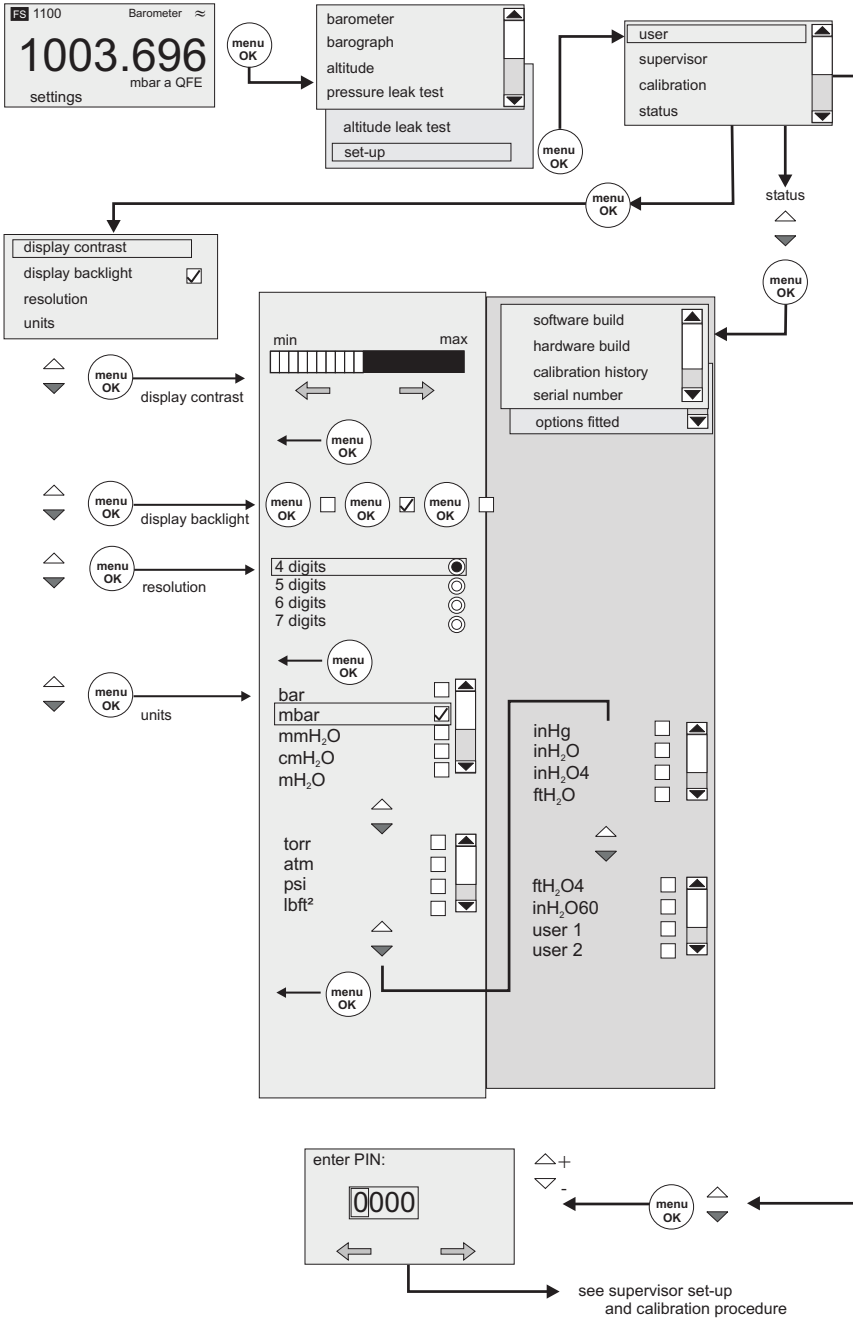

Barograph

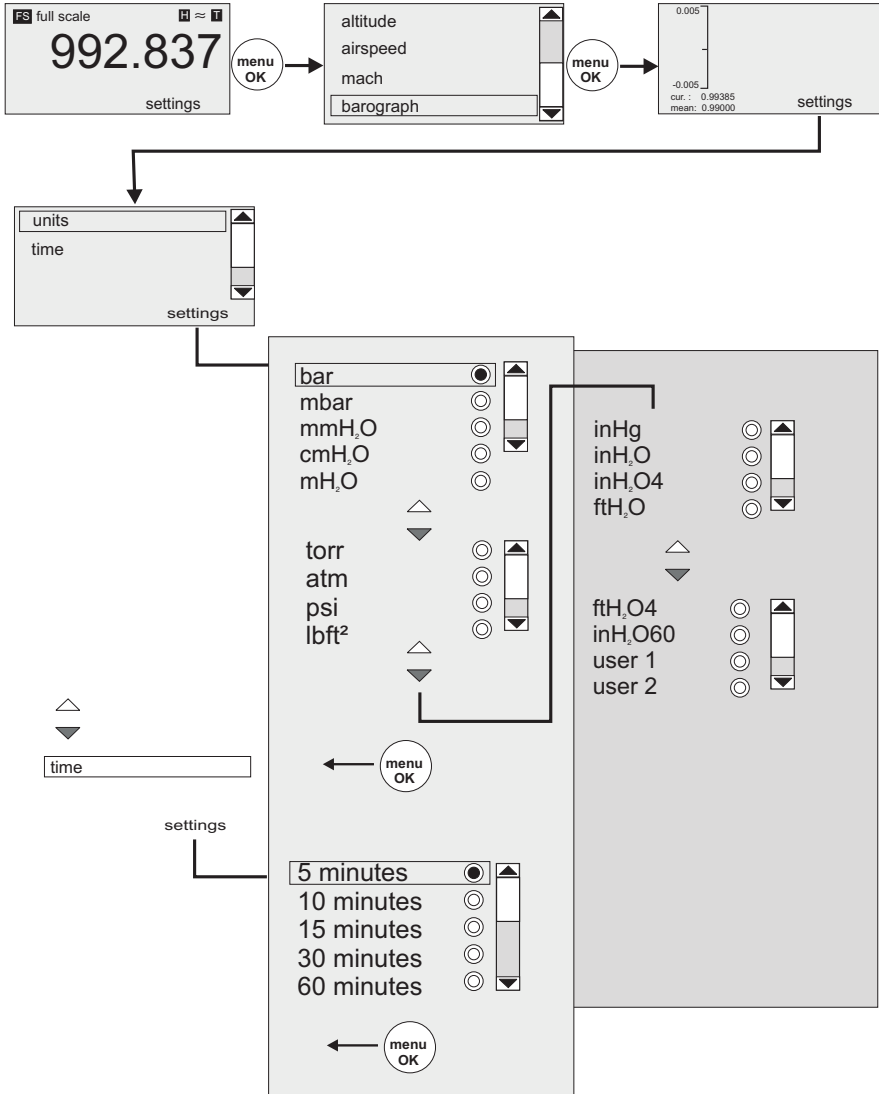

Altitude

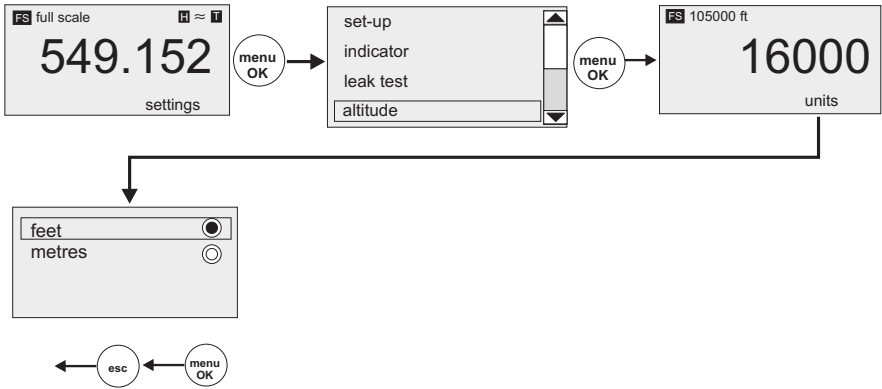

English

Pressure Leak Test

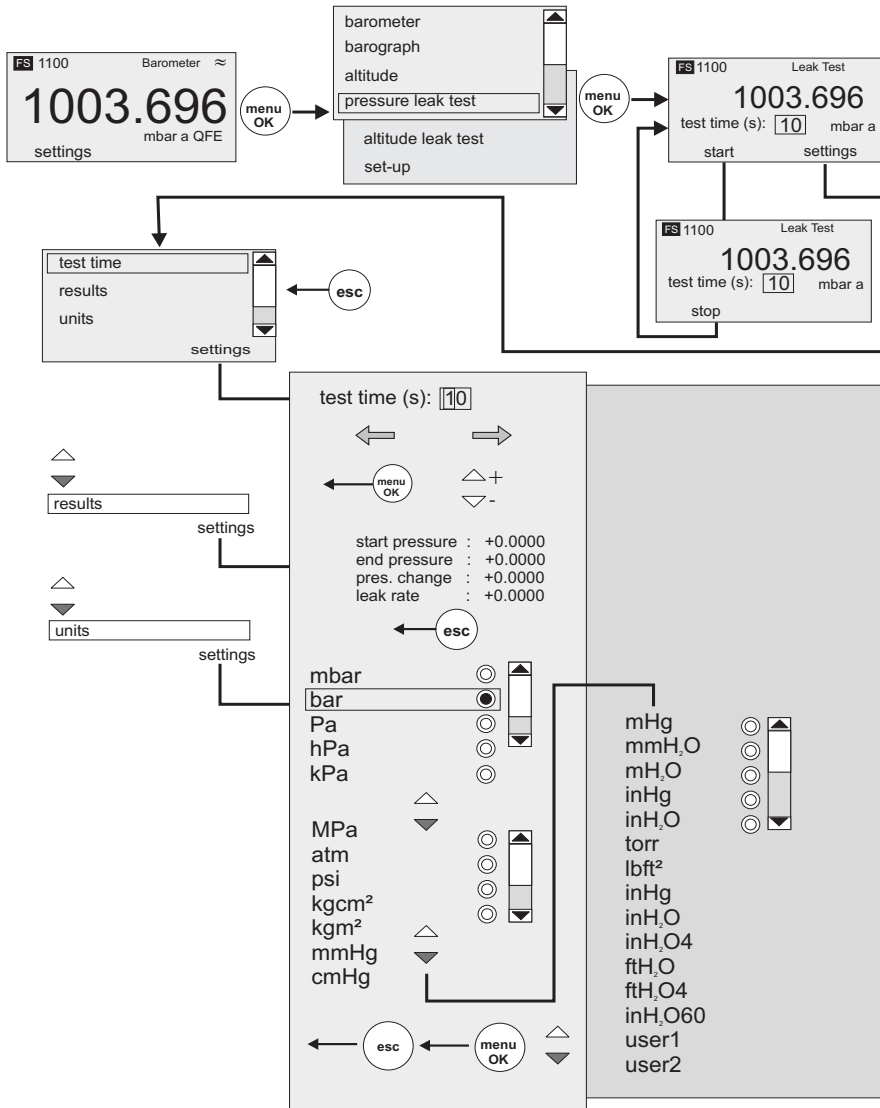

Supervisor Set-up

English

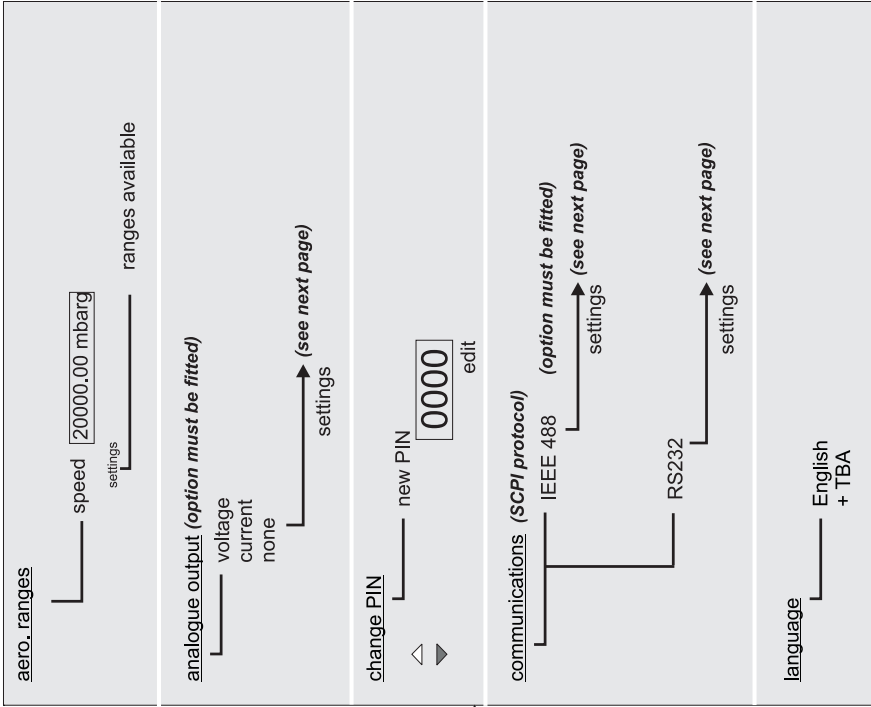

Supervisor Set-up (continued) Communications Option

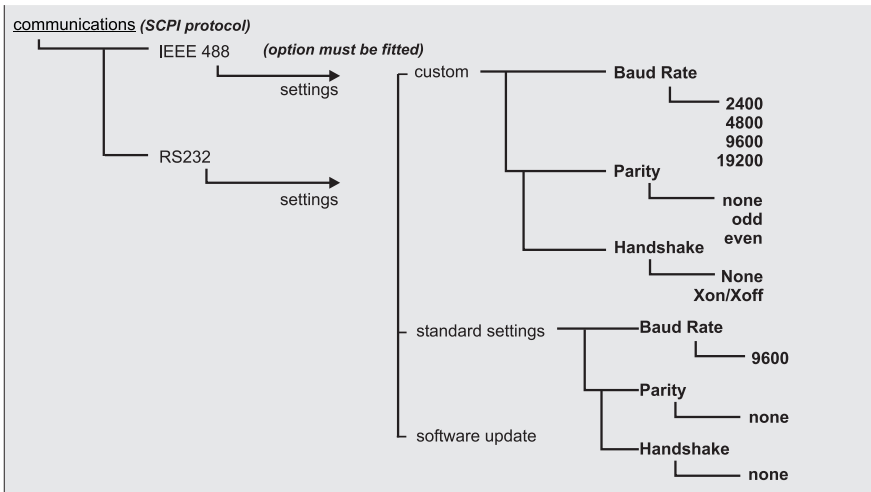

Supervisor Set-up (continued)
Analogue Output Option

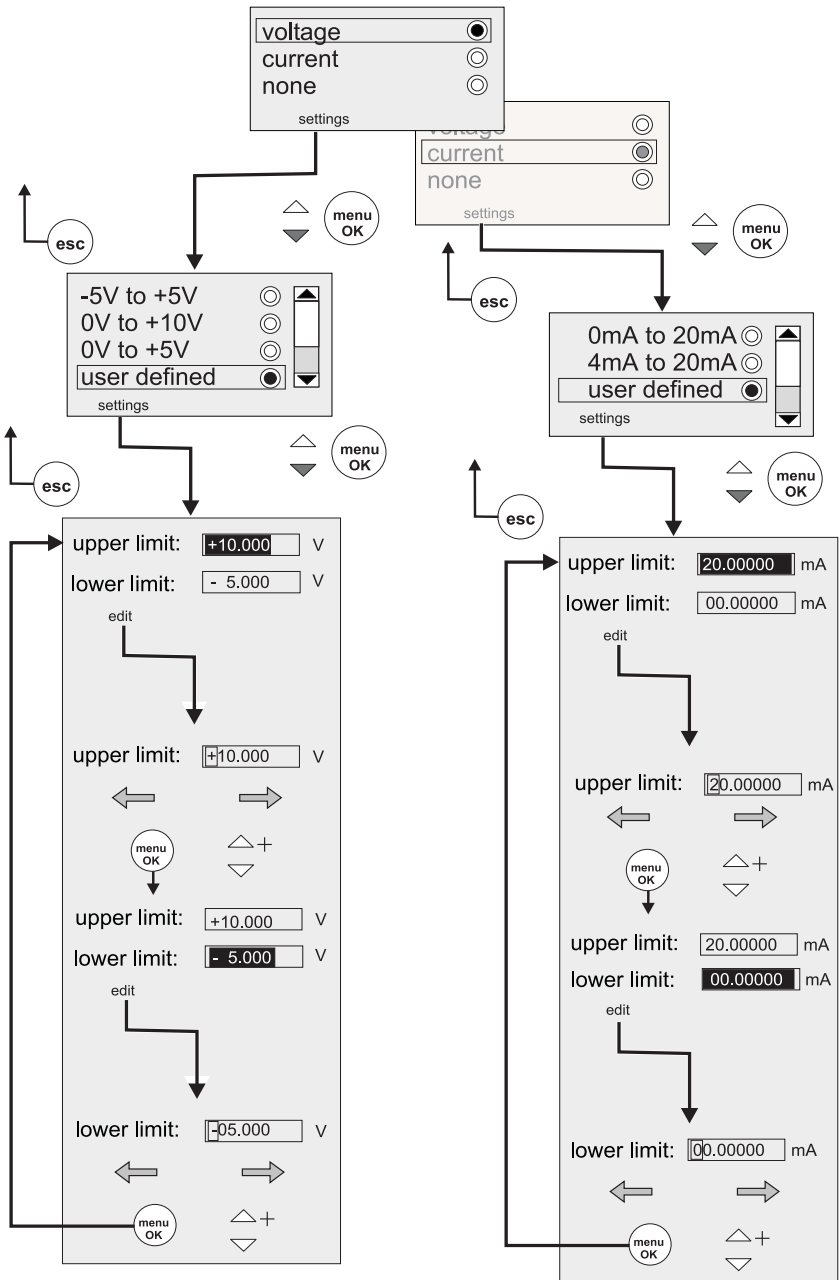

intentionally left blank