



CR-4000

Four Channel Controller

4-20 mA Fixed Gas Monitoring System

Installation and Operating Instructions



"INNOVATORS IN GAS DETECTION"



Table of Contents

Title	Page
Safety Information	ii
Contacting BW Technologies	ii
Introduction	2
Installation	3
Mounting	4
4-20 mA Wiring	7
Power Connection	8
Relay Connection	9
Battery Backup	10
Battery Connections	10
Set-up	11
Channel Select	12
Power Up	13
LCD Display Calibration	13
Alarm Setup	14
Alarm Relay Configurations	15
Operation	16
Maintenance	17
Battery Backup (Field Installation)	18
Notes	19
Specifications	20
Warranty	21

List of Figures

Figure	Title	Page
1.	Elements Drawing	1
2.	Enclosure Outline Drawing	3
3.	System Wiring Diagram	5
4.	Main Board Elements Diagram	6
5.	4-20 mA Wiring Guide	7
6.	Power Select Wiring Guide	8
7.	Battery Backup Connection	10
8.	Battery Backup Kit Assembly Drawing	18

List of Tables

Table	Title	Page
1.	Measuring Range Selection	12
2.	LCD Calibration - Dip Switch Position	13
3.	LCD Symbol/Message	16
4.	Troubleshooting Guide	17
5.	Replacement Parts	18

Safety Information - Read First



Important

FOR SAFETY REASONS, THIS EQUIPMENT MUST BE OPERATED AND SERVICED BY QUALIFIED PERSONNEL ONLY. READ AND UNDERSTAND THE USER MANUAL COMPLETELY BEFORE OPERATING OR SERVICING.





Caution

- ⇒ **Warning: Substitution of components may impair Intrinsic Safety.**
- ⇒ **The controller warranty will be void if the unit is disassembled, adjusted, or serviced by non-BW Technologies personnel.**
- ⇒ **Do not use the controller if it or any system components are damaged. Inspect the system on a regular basis and maintain a log. If the controller is damaged or parts are missing, contact BW Technologies immediately.**
- ⇒ **Do not attempt to disassemble, adjust, or service the controller unless instructions are provided in this manual for that procedure and/or that part is listed as a replacement part. Use only BW parts.**
- ⇒ **Do not expose the controller to electrical shock or severe continuous mechanical shock.**
- ⇒ **Do not change or charge batteries in a hazardous location. Doing so will impair the Intrinsic Safety of the controller and can cause a fire and/or explosion.**
- ⇒ **Warning: Do not disconnect or replace assemblies/equipment unless power has been switched off or the area is known to be non-hazardous.**
- ⇒ **Any rapid up-scaling reading followed by a declining or erratic reading may indicate a gas concentration beyond upper scale limit, which may be hazardous.**
- ⇒ **Electromagnetic Interference (EMI) signals may cause incorrect operation.**

Ratings and Certifications

Symbol	Meaning
	Approved to both U.S. and Canadian Standards by the Canadian Standards Association.
IEC	Certified to IEC (International Electrotechnical Commission)
	Conforms to European Union directives

International Symbols

Symbol	Meaning
	Protective Earth Conductor Terminal (Ground)
	Caution (consult all accompanying documents, product labels and markings)
	Recyclable
	Waste Disposal

Contacting BW Technologies

To contact BW Technologies call:

USA: 1-888-749-8878

Canada: 1-800-663-4164

Europe: +44 (0) 1869 233004

Other countries: +1-403-248-9226

Email us at: info@bwt.net

Visit BW Technologies' website: www.gasmonitors.com

Address correspondence to:

BW Technologies LP
2840 2nd Ave. S.E.
Calgary, AB T2A 7X9
Canada

BW America
3279 West Pioneer Parkway
Arlington, TX 76013
USA

BW Europe
101 Heyford Park
Upper Heyford, Oxfordshire, OX25 5HA
United Kingdom

Installation and Operating Instructions

Figure 1: Elements Drawing

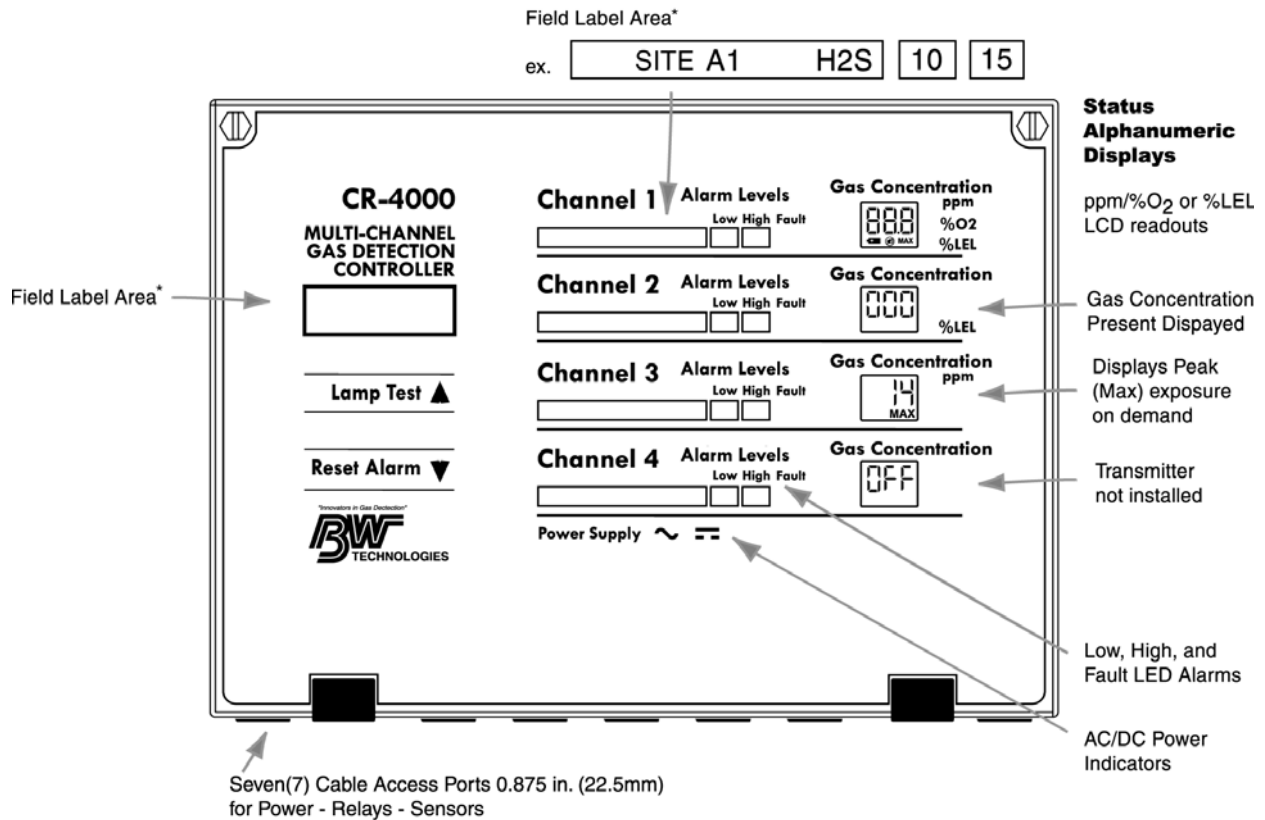

*Field Label Areas: White Blank areas provided for customer to label.

***Field Area Label:** White areas are provided to label the controller with field specific information. The areas are provided for

- the general controller label, and
- general and low/high alarm setpoints (three labels per channel).

Compatibility

The CR-4000 Controller (the controller) has a direct linear isolated output making it compatible with most 4-20 mA gas transmitters, as well as the following BW Technologies transmitters:

- GasPoint
- GasPoint IR
- I.S. Plant Rat
- CD-420 Series
- ToxyPoint
- RRJ-sensor/transmitters

Introduction

The CR-4000 is a microprocessor based four-channel controller with four independent LCDs. Each channel is capable of measuring and controlling gas detectors that use 4-20 mA output with varying measuring ranges (refer to *Channel Select* on page 12). The controller channel field selectable switches are programmed for easy set-up when selecting measurements.

One rotary switch and two dip switches are used to set-up each channel.

Rotary Switch: The rotary channel select switch is used to select the range and type of gas.

Dip Switches: The two dip switches are used to

- set the low alarm setpoints,
- set the high alarm points,
- configure the audible alarm, and
- configure the relays.

LED Indicators: Each LCD displays six LED indicators;

- low alarm
- high alarm,
- fault alarm, and
- gas type (O₂, PPM, %LEL).

Fault Conditions: During fault conditions, the following icons display.

- **-OC** (Open Circuit) displays to indicate that there is no gas detector installed.
- **-SC** (Short Circuit) displays if the detector is causing a short in the power line of the channel.
- **-FC** (Fault Condition) displays if the input signal is below 2 mA.

Common Audible Alarm: The common audible alarm (two 75dB buzzers) activates for all channels when an alarm condition occurs. **Note:** Each channel can be isolated (disabled) from the common audible alarm, using the AUDIBLE dip switch.

Relays: The controller is equipped with three relays.

- Non-latching, de-energized, common low alarm relay
- Latching, de-energized, common high alarm relay
- Energized common fault relay

Low and High Optional Relays: The controller can be ordered with two additional relays (low and high) per channel. Optional relays are function selectable using the dip switches. These relays are field selected to function as energized/de-energized and latching/non-latching.

Control Switches: The two front panel pushbuttons Reset Alarm ▼ and Lamp Test ▲, are used as control switches to

- acknowledge/reset alarms,
- perform general system tests,
- calibrate the LCD (if required), and
- adjust the alarm set points when in calibration mode.

Controller Power: The controller power is field selectable for either

- 110 Vac or 220 Vac 50/60 Hz, or
- 24 Vdc operation.

Select the desired power option on the power select slide switch. The controller can also operate from external power (18-28 Vdc 1.5A). Optional battery backup (2 x 12 V 1.8 amphr. in series) is available.

Note: The power is not field selectable in the Hazardous Location Division 2 version.

Enclosure: The controller is housed in a slim wall mounted, hinged swing-down door enclosure. All wiring terminals are located inside, opposite the applicable port for conduit/compression fitting. The enclosure is enameled steel and RFI/EMI protected.

Installation

Figure 2: Enclosure Outline Drawing

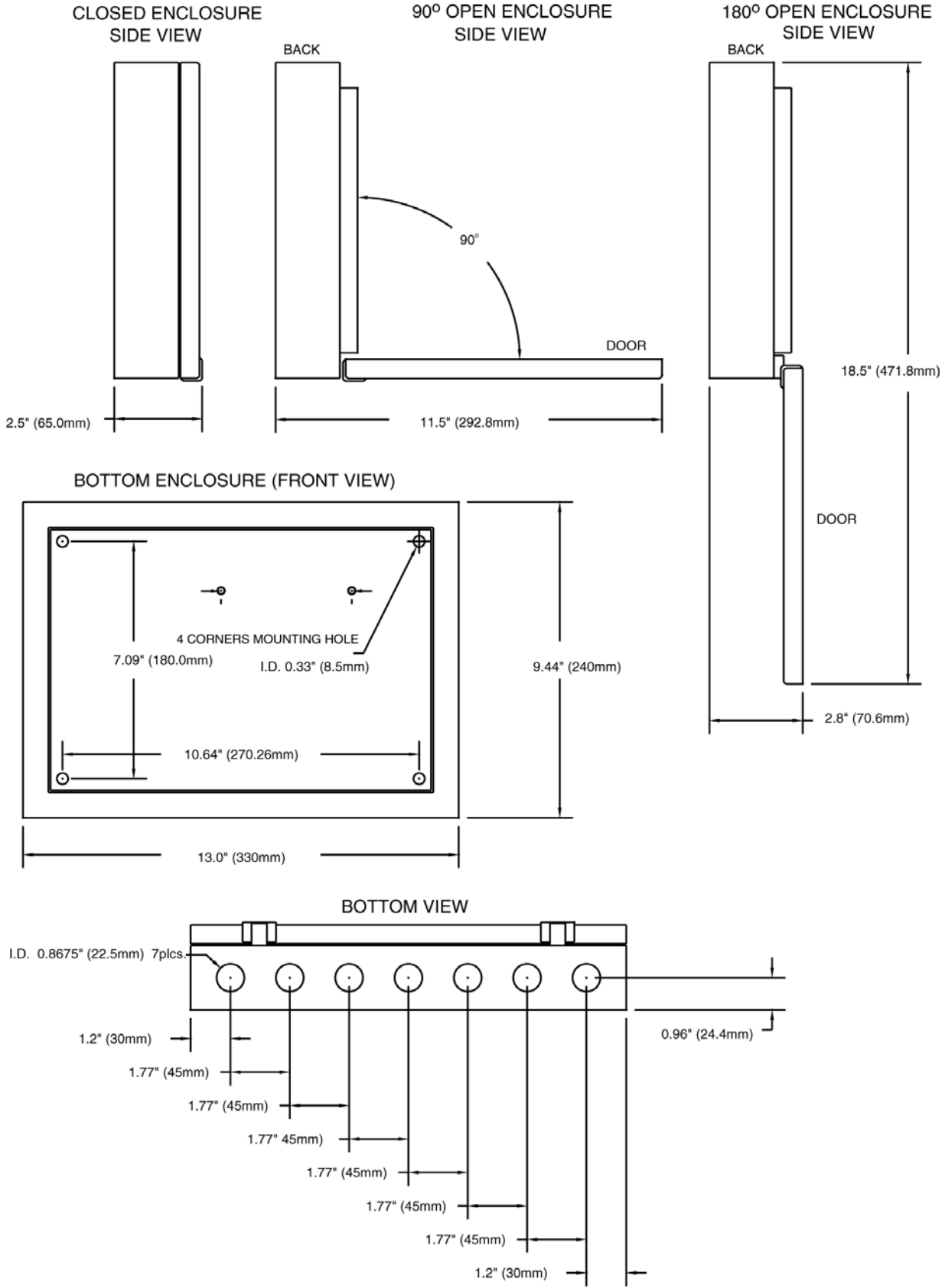

General

The controller is designed for installation in a general-purpose or Class I, Division 2 hazardous area.

Note: For Division 2 versions, Division 2 installation rules must be followed. Installation personnel must be qualified technicians.

Adhere to all required electrical codes and safety standards during the installation. If the controller is to be located in a Division 2 area, refer to section *Class I, Division 2 Installation* on page 4.

Recommended: Use the recommended (supplied) port glands in all unused ports.

⚠ Caution

The circuit has live terminals. Installation and maintenance must be performed by qualified personnel only.

Mounting (Figure 2)

Prior to mounting the controller, ensure the following:

- Locate a mounting wall where there is minimum vibration
- The mounting wall is away from local heat
- There is adequate ventilation
- Provides easy access/reach for operating personnel

The mounting wall must provide support for the 2.2 kg (4.85 lbs.) controller. Ensure that the electrical cable/conduit routing and support are planned. Refer to *Figure 2* for cable/conduit port location and enclosure mounting flanges.

1. Remove the two #10 Phillips top screws and open the swing-down door of the controller. Remove the four small rubber bumpers on the back of the enclosure. Use the four mounting flanges as a template to mark the mounting holes. Drill the required holes.

Note: Front door can be removed. First, remove the grounding wire from the front enclosure (refer to Grounding in step #2). Next, using a small tool depress the lock side of the white hinge pins and pull out. To replace the pins, line up the hinges and reinsert the hinge pins. To reinstall the grounding wire, refer to the following illustration.

2. Replace the four rubber bumpers. Mount the enclosure by inserting the four screws through the rubber bumpers into the wall to ensure the enclosure rating. Secure in place.

Grounding: Ensure the ground (earth) wire remains connected between the lid and the case. Ensure it is installed correctly.

3. Ensure the enclosure is grounded using the 5 mm x 12 mm stud at the bottom left side of the enclosure back.
4. Ensure the enclosure door is grounded using the stud that is located beside the transformer.

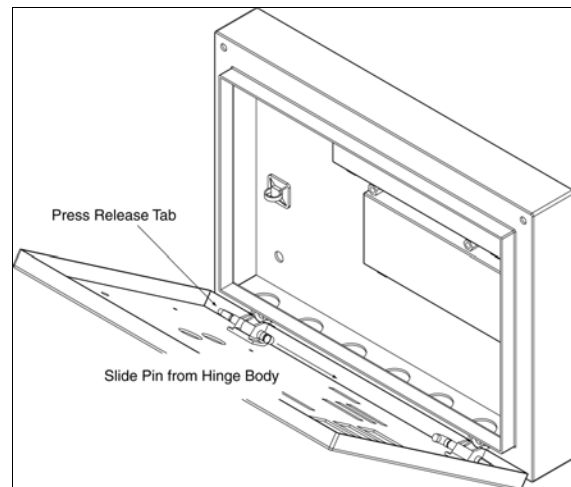

Class I, Division 2 Installation

One version of the CR-4000 Controller has been certified for installation in a Division 2 hazardous location. Adhere to the following when ordering the Division 2 version.

- Conduit or approved hazardous location cables must be used when connecting devices to the controller.
- Approved seal fittings must be installed within 18 in. (45.72 cm) of the controller at each port.
- Hazardous location cable and seal fittings must be approved for Class I, Div. 2 Gr. A, B, C, D hazardous locations.
- Practice approved National Electrical code installation methods.

Installation

Figure 3: System Wiring Diagram

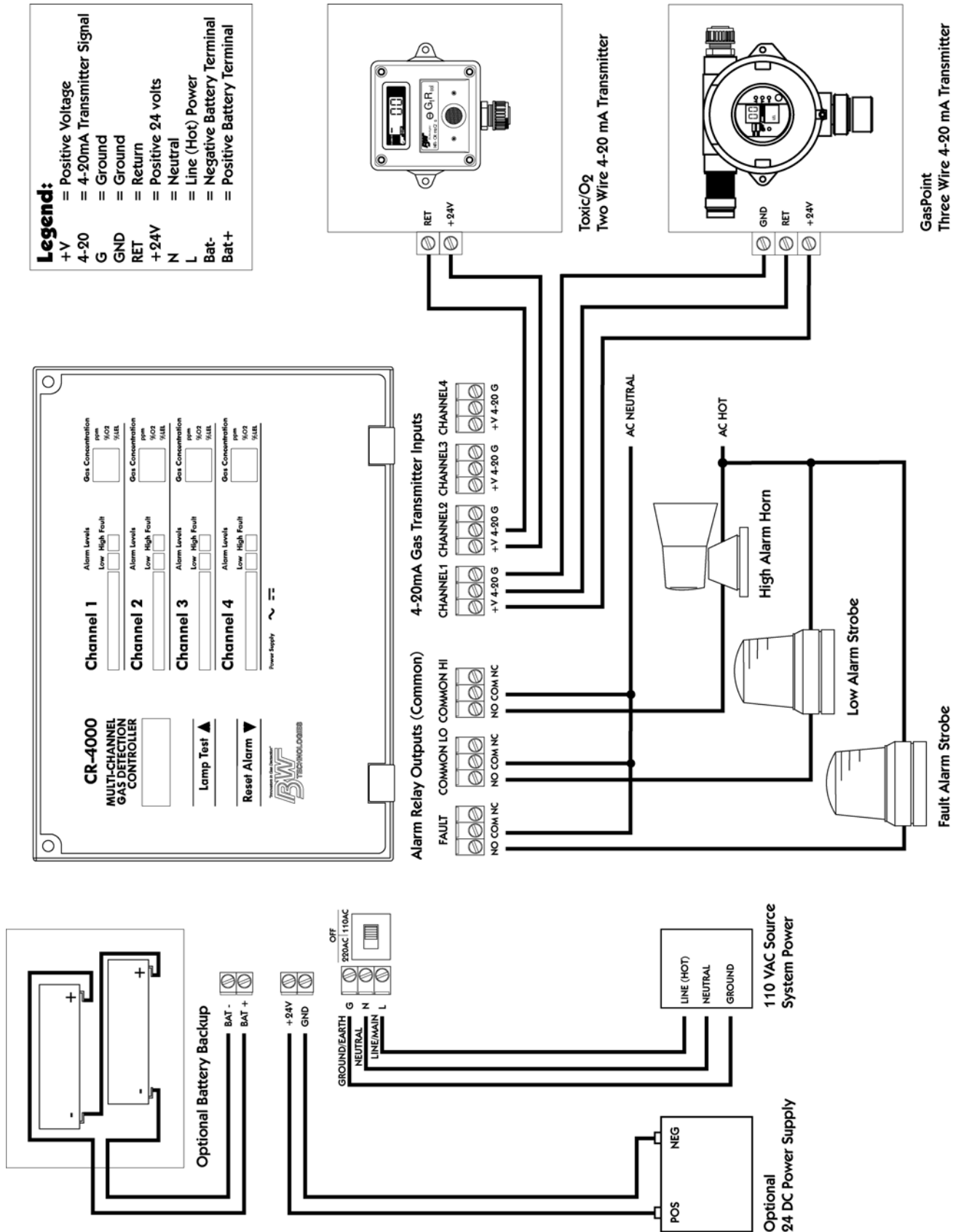
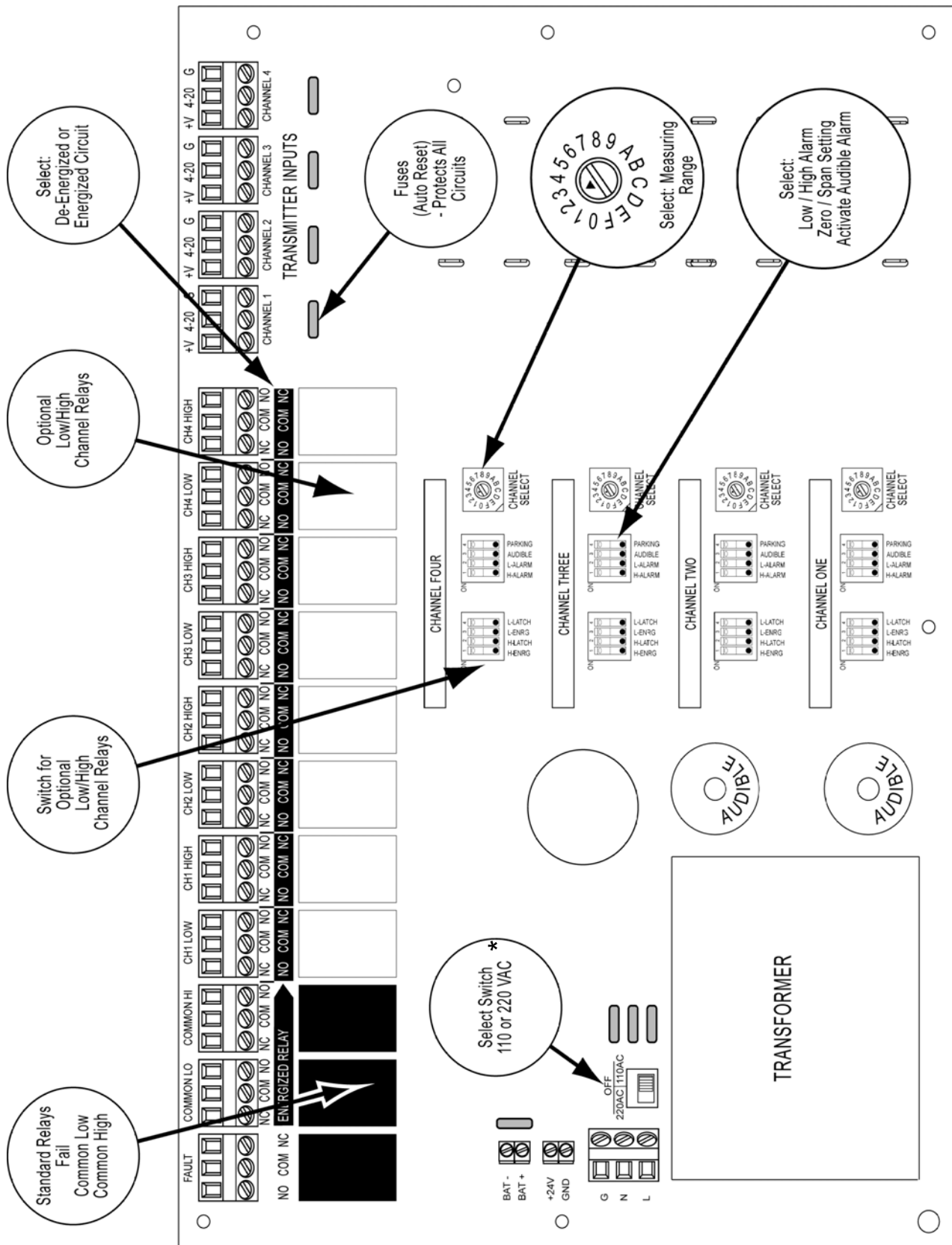

Figure 4: Main Board Elements Diagram



* Available in ordinary location version.

Installation

4-20 mA Transmitter Wiring: Refer to Figure 3 and Figure 4.

Specifications

Cable Power:	16-20 AWG (dependant upon distance)
Relays:	16-22 AWG
Electrical Supply:	115 Vac, 0.18 A; 230 Vac, 0.36 A; 50-60 Hz; 24 Vdc, 1.5 A (field selectable)
Controller Resistance:	121 ohm
Wiring Ports:	3.4 in. (1.77 in.; 44.98 mm)

- Note 1:** Review the layout diagram that is provided inside the case before proceeding.
- Note 2:** Extend wiring leads 5.5 in. (minimum) in length inside the unit (refer to wire cut line in case drawing).
Exception: Power line, extend a minimum of 9 in. inside the case.

General

The 4-20 mA input of the controller receives its loop current from +24 Vdc supply (+V terminal) that is built into the controllers. The dc supply is connected to the transmitter when the transmitter wiring connection is made. The +V terminals are protected by a resettable (auto) fuse and each can manage up to 250 mA of load current.

- Using the port that is closest to the selected channel terminal block, route the signal cable through the signal port. Extend the cable until it reaches the selected channel terminal block. The cable length must be minimum 5.5 in. (14 cm) inside the unit.
- Use a small, flat-head screwdriver to loosen the screw on the channel terminal block.
- Strip approximately 5/16 in. (8 mm) of insulation from one end of each wire and insert the wire at the assigned terminal. Do not over tighten the terminal screws. Refer to the 2-wire and 3-wire 4-20 mA transmitter wiring in Figure 5.

Figure 5: 4-20 mA Wiring Guide

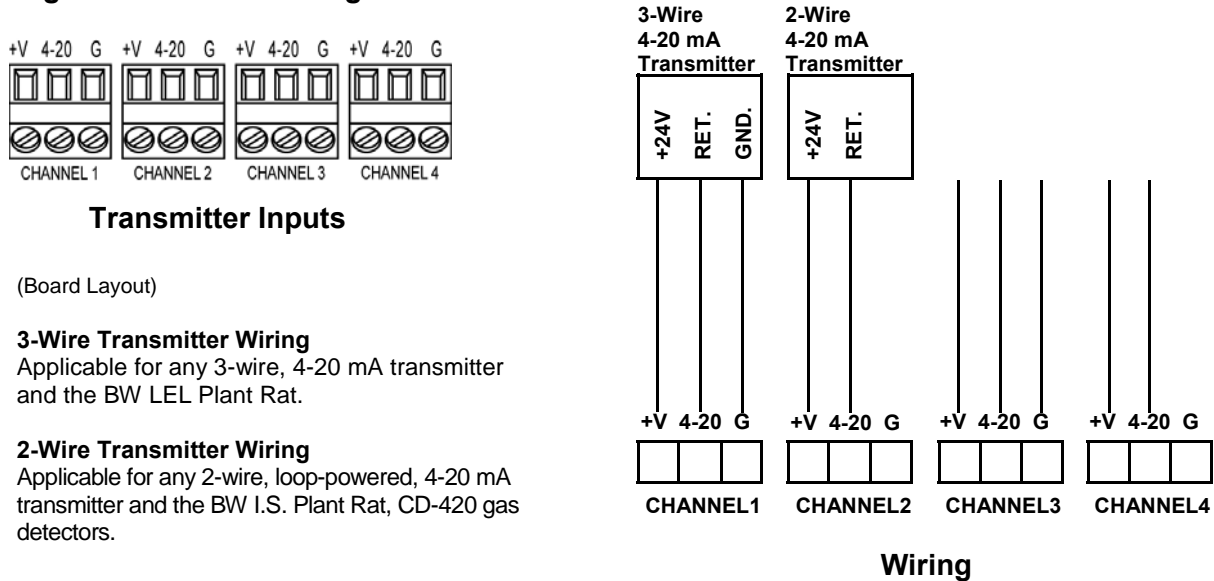

Power Connection

⚠ Warning

To avoid electrical shock, ac power must not be connected to the distribution panel (ac source) until all wiring procedures are completed.

⚠ Caution

- ⇒ Main supply voltage fluctuations are not to exceed 10% of the nominal supply voltage.
- ⇒ A circuit breaker must be included in the building installation as a disconnect device for the equipment. The disconnect device must be installed in close proximity to the equipment, and the device must be marked as a disconnecting means for the equipment.
- ⇒ Before applying power, set-up the channel select switches (refer to page 12).
- ⇒ All power wiring must be in compliance with the requirements of applicable local electrical codes and regulations, as well as industry regulations.

1. Route the power cable through the far left cable/conduit port. Extend the cable until it reaches the ac terminal block.
2. Use a small, flat-head screwdriver to loosen the screw on the ac terminal block.
3. Strip approximately 5/16 in. (8 mm) of insulation from one end of each wire and insert wires at the assigned terminal. Secure terminal screws (do not overtighten). Connect the ac power to the three-pin terminal block. The block is labeled as N (neutral), L (line/hot), and G (ground).
4. Secure the wire in the grey cable tray.
5. Select either 110 Vac or 220 Vac power by switching the power slide switch to 110 V or 220 V.

Note: The power can only be selected from the ordinary location version of the controller.
If external dc power is preferred, the two pin terminal block labeled EXTERNAL +24 Vdc can be used.

Figure 6: Power Select Wiring Guide

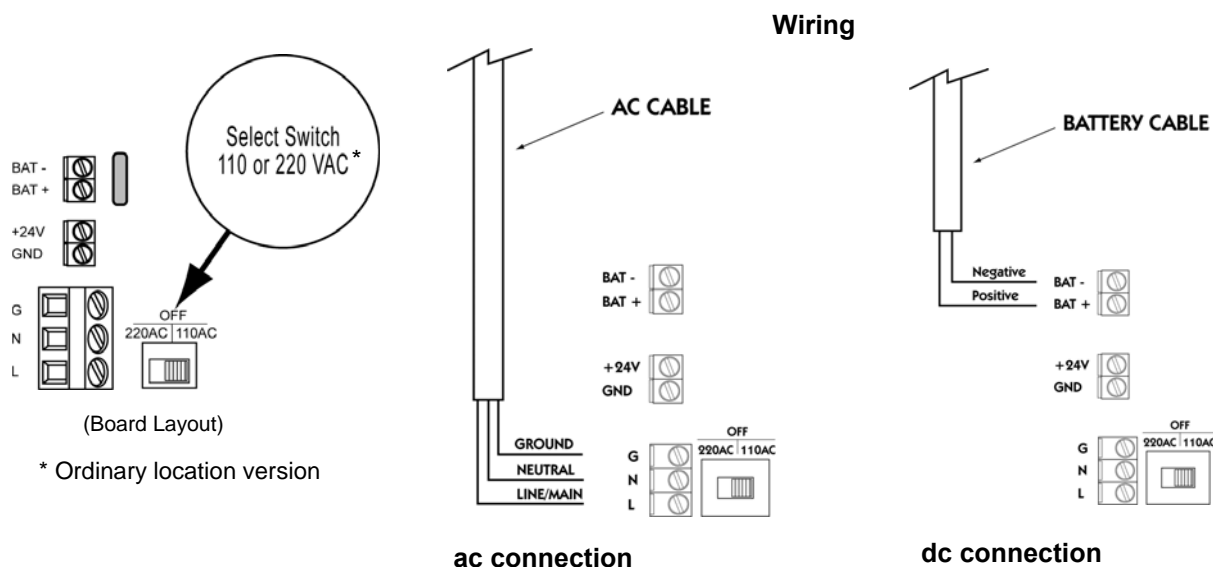

Auto Reset

Fuses reset automatically when the circuit power returns to normal. Fuse replacement is not required.

Installation

Relay Connection

Specifications

Type:	SPDT
Load:	Resistive Load (p.f. = 1)
Rated Load:	10 amps at 120 Vac; 8 amps at 30 Vdc
Carry Current:	10 amps
Max. Operating Voltage:	250 Vac; 125 Vdc
Max. Operating Current:	10A ac; 8A dc
Max. Switching Capacity:	1250VA, 240W

Four relay wiring ports are provided for convenience. All controllers are equipped with three standard relays. The relays are the

- common fault,
- common low alarm, and
- common high alarm.

Individual low and high channel alarms are optional and are factory installed when the controller is ordered.

1. Route the relay cable through each relay cable/conduit port. Extend the cable minimum 5.5 in. Use a small, flat-head screwdriver to loosen the connection on the required relay terminal blocks.
2. Strip approximately 5/16 in. (8 mm) of insulation from one end of each wire and insert the wires at the selected terminal. Secure terminal screws (do not over tighten). The relay connections are made to the 3-pin terminal block and are labeled as
 - NO (normally open),
 - COM (common), and
 - NC (normally closed).
3. Select the required configuration.

⚠ Caution

Refer to *Alarm Relay Configurations* (page 15) prior to wiring the optional channel relays, and before selecting the energized or de-energized relay.

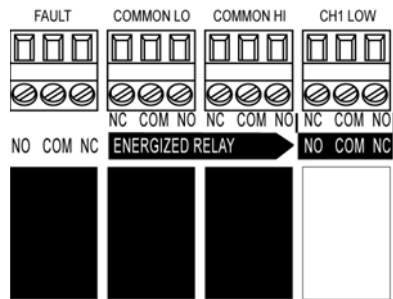

Channel Relay

Common Relays

Battery Backup

The battery backup is an optional accessory to the controller. Two 12 V, 1.8 Ah, rechargeable sealed, lead acid batteries are connected in series to supply the 24 V backup. If the battery backup is installed in the controller, the battery wire harness must be connected to the BAT+ and BAT- terminals during the installation process (refer to *Figure 7: Battery Backup Connection* below). When an ac or dc source is used, battery backup power is charged continuously.

If the dc source is being used and battery backup is required, the dc supply voltage must be 24 V or higher (27.5 V is recommended) to charge the two batteries in series to maximum capacity.

Refer to *Figure 8: Battery Backup Kit Assembly Drawing* for field installation of the optional battery.

Battery Connections

⚠ Caution

Remove the heat shrink tubing from either the red or black wire. The heat shrink tubing must be removed from each wire (red or black) one at a time to avoid shorting the wires.

Figure 7: Battery Backup Connection

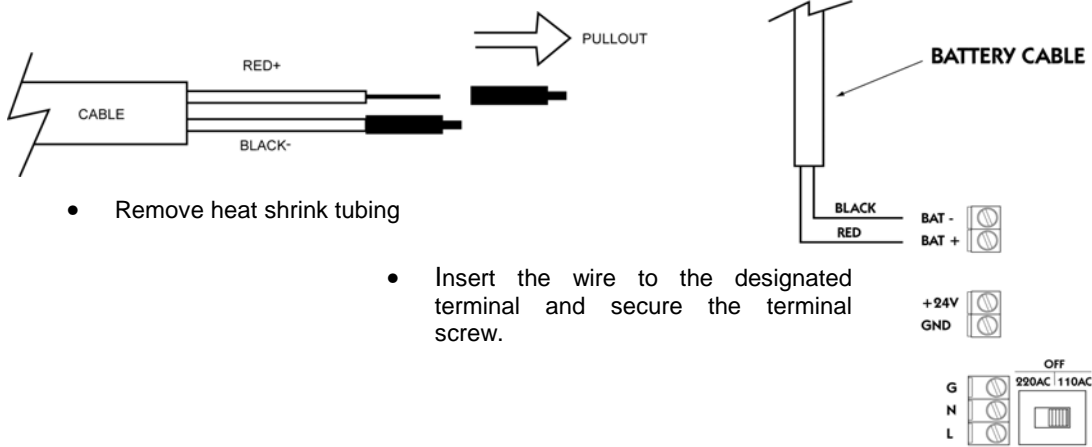

Set-up

Introduction

After installation is complete, the controller must be set-up prior to operation.

The controller set-up requires

- selecting the correct sensor types and measuring ranges for each individual channel,
- setting the low and high alarm setpoints,
- zeroing the LCD / spanning and calibration, and
- setting the alarm relays (optional).

The following steps are required to set-up the controller. Perform the steps in the order they are provided.

- Channel Select* – The channel select switches are factory set to 0 (zero). Set-up the channel select switches before applying power to the controller (refer to Table 1 on page 12).
- Power Up* – Apply power to the controller (page 13).
- LCD Calibration* – The LCD calibration procedures are used to zero and span the LCD of Channel 1. Repeat the LCD calibration for Channel 2, Channel 3, and Channel 4 (page 13).
- Alarm Set-up* – Set the low and high alarm trip-points. Repeat the alarm set-up for Channel 2, Channel 3, and Channel 4 (page 14).
- Alarm Relay Configurations (Optional)* – If the alarm relays are installed, refer to the configuration procedures to set-up the low and high alarm relays (page 15).

A. Channel Select

The channel select switch is used to set the gas measuring range.

1. Identify the measuring range of the 4-20 mA transmitter that is connected to the Channel 1 terminal connection (refer to *Table 1 Measuring Ranges Selection*).
2. Using the screwdriver provided, rotate the pointer to the required measuring range for Channel 1.
3. Repeat steps #1-2 for Channel 2, Channel 3, and Channel 4.
4. If a transmitter is not connected to the channel terminal connection, rotate the channel select switch to 0 (zero).
Note: If the channel select switch is positioned to 0, the power of the terminal connection is disabled and the LCD displays **OFF**.

Sample

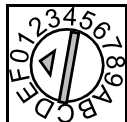

0 - OFF

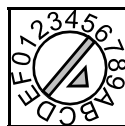

A - 0 to 200 ppm

Table 1: Measuring Ranges Selection

Switch Position (Arrow Point)	LED Gas Indicator	Range	Display/Resolution
0	None	None	OFF
1	O ₂ (% by vol.)	0-25 (% by vol.)	0.1 (% by vol.)
2	%LEL	0-100%	1%
3	PPM	0-1.0	0.1 ppm
4	PPM	0-5.0	0.1 ppm
5	PPM	0-10	1 ppm
6	PPM	0-10.0	0.1 ppm
7	PPM	0-20	1 ppm
8	PPM	0-50	1 ppm
9	PPM	0-100	1 ppm
A	PPM	0-200	1 ppm
B	PPM	0-500	1 ppm
C	PPM	0-1000	2 ppm
D	PPM	(Multi) 0-20mA	On
E	None	(Smoke) 0-20mA	On
F	O ₂	0-30	0.1

Multi-Gas (0-20 mA) Application: For future use.

Smoke Sensing Device (0-20 mA) Application: The smoke sensing device channel is used for devices with high output current in standby or non-alarm condition.

Because the output current is too high to zero adjust, the LCD displays

- **On** when the channel is below the alarm trip-point, and
- **AL** when the current of the device is over the alarm trip-point.

When setting the low and high alarm setpoints, set the LCD to the equivalent mA units. If the desired alarm setpoint is 18.5 mA, adjust the LCD to display **18.5 mA**. All alarm indicators react to the detector the same way it reacts to the 4-20 mA gas transmitter.

Set-up

B. Power Up

During power up, the Channel 1 transmitter is enabled and the LCD begins the start-up countdown (from **5** to **0**). When the countdown is complete, the LCD displays the signal level of the 4-20 mA transmitter that is connected to Channel 1. The start-up process begins for Channel 2 and then continues for the remaining channels.

C. LCD Calibration

Because the measuring ranges of the channel select switches are fixed, the LCD reading is normally the equivalent value of the 4-20 mA transmitter measured by the particular channel.

The LCD zero and span adjustments of the controller are useful to 4-20 mA transmitters that do not have zero and span adjustments. The controller LCD zero and span adjust is also used to fine adjust transmitters with significant tolerance between LCD readings and the measured value of the transmitter.

⚠ Caution

The zero adjust procedures must be performed before the span adjust procedures.

Zero Adjust

1. Set the calibration dip switches as shown in *Table 2*. The LCD then displays **CAL** and the zero value of the transmitter.
2. Apply zero gas to the sensor of the 4-20 mA transmitter (if ambient air is used, ensure there is no gas present).
3. If the 4-20 mA transmitter is equipped with LCD and zero/span adjust, set the transmitter to display zero.
4. On the front panel of the controller, press Lamp Test ▲ or Reset Alarm ▼ to increase/decrease the existing value to display zero for the selected channel.

Span Adjust

1. Set-up the calibration dip switches for span adjust as shown in *Table 2*. The LCD then displays **SPn** and the span value of the transmitter.
2. Apply a known concentration of gas to the sensor of the 4-20 mA transmitter.
3. On the front panel of the controller, press Lamp Test ▲ or Reset Alarm ▼ to increase/decrease the existing value to display the required concentration of test gas being used for the selected channel.

Recommended: Apply a test gas concentration that is at least 25% of the full scale of the measuring range.

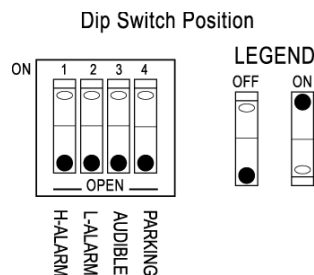

Dip Switch Position				
	Alarm 1 (High)	Alarm 2 (Low)	Audible	Parking
Zero Adjust	ON	ON	ON/OFF	OFF
Span Adjust	ON	ON	ON/OFF	ON

D. Alarm Set-up

Each controller channel has four dip switches that are used to set-up the

- low alarms,
- high alarms,
- audible alarms, and
- parking mode.

The alarm trip-point for the low and high alarms can be adjusted by using the corresponding pushbutton switches and the configuration dip switch.

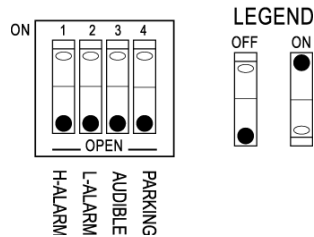

Low Alarm (L-ALARM)

To change the low alarm trip-point of the selected channel, toggle the L-ALARM dip switch to the ON position and the H-ALARM to OFF. The low alarm LED activates to indicate the alarm point is being changed. Press Lamp Test ▲ or Reset Alarm ▼ to increase/decrease the existing value.

High Alarm (H-ALARM)

To change the high alarm trip-point of the selected channel, toggle the H-ALARM dip switch to the ON position and the L-ALARM to OFF. The high alarm LED activates to indicate the alarm point is being changed. Press Lamp Test ▲ or Reset Alarm ▼ to increase/decrease the existing value.

Audible Alarm (AUDIBLE)

The audible alarm is common to all channels on the controller. Any alarm condition (low, high, or fault) will activate the audible alarm for all channels. However, the AUDIBLE switch can be used to isolate (disable) a channel from the common alarm.

To isolate a channel from the common audible alarm, toggle the AUDIBLE dip switch to the OFF position.

ⓘ displays for the selected channel to indicate it is disabled from the common audible alarm.

Parking Mode (PARKING)

The parking dipswitch is used specifically for the low and high alarm relays.

On: Set the dipswitch to ON to define the alarm condition. If the alarm condition is low, the low alarm activates. If the alarm condition changes to high, the high alarm then activates and the low alarm deactivates.

Off: Setting the PARKING mode to OFF activates only the low alarm. To ensure that personnel leave the monitored area even in a low alarm condition, set the dipswitch to OFF.

Set-up

E. Alarm Relay Configurations (Optional)

The alarm relay configuration procedures apply only to controllers with the following optional relay models:

- CR4-R1000
- CR4-R1200
- CR4-R1230
- CR4-R1234

Each controller channel has four dip switches that are designated to individually control the low and high alarm relays. These control switches can be set to configure the desired relay to function as energized or de-energized, and to operate as latching or non-latching (self-clearing).

Optional Low/High Alarm Relay Dip Switches

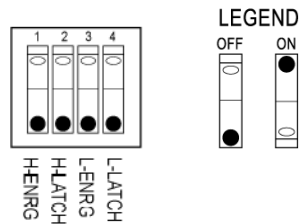

Low Alarm Energized (L-ENRG): Set the switch to ON to energize the low alarm relay of of the selected channel. Two wiring labels for normally open (N/O) and normally closed (N/C) contacts identify the terminal wiring of the relay. Use the label ENERGIZED RELAY if the energized relay is selected.

Low Alarm Latched (L-LATCH): Set the switch to ON to operate the low alarm relay in latching mode for the selected channel. The latch mode activates during a low alarm condition and remains activated, even when the low alarm condition no longer exists.

High Alarm Energized (H-ENRG): Set the switch to ON to energize the high alarm relay of the selected channel. Two wiring labels for normally open (N/O) and normally closed (N/C) contacts identify the terminal wiring of the relay. Use the label ENERGIZED RELAY if the energized relay is selected.

High Alarm Energized (H-LATCH): Set the switch to ON to operate the high alarm relay in latching mode for the selected channel. The latch mode activates during a high alarm condition and remains activated, even when the high alarm condition no longer exists.

Operation

Introduction

Transmitter Status: The LCD displays the status of the transmitter as follows:



- Alarms: Low (red), high (red), and fault (amber)
- Power: On, ac or dc (green)
- Gas: Measuring ppm, %O₂, or % LEL

General System Test: To perform a general system test, press Lamp Test ▲. All of the LEDs (six per channel) and the audible alarm activate.

Maximum Gas Level Detected (MGLD): To view the MGLD, press Reset Alarm ▼. **MAX** and the MGLD value display on the LCD. The maximum gas level displays continuously. If a higher level is detected, the new value automatically displays. To clear the MGLD, press and hold Reset Alarm ▼ for 3 seconds until **CLr** displays.

Acknowledge Alarm and Reset Latched Relay: To acknowledge and reset the relay after an alarm, press Reset Alarm ▼. The relay resets when the gas level drops below the latching alarm setpoint.

Table 3: LCD Display Symbol/Message

Message	Description
OFF	The channel select switch is positioned to 0 (zero) and the channel is off. When the channel is off, power is not available to the channel power terminal (V+).
-OL	Overload: The signal level of the 4-20 mA transmitter is over 20 mA.
-OC	Open Circuit: No gas detector is installed. The common fault relay and the LED fault indicator are activated.
-SC	Short Circuit: The gas detector is causing a short in the power line of a particular channel. The common fault relay and the LED fault indicator are activated.
-AL	Channel is in smoke detection mode and is in alarm.
-FC	Fault Condition: The signal level of the 4-20 mA transmitter is below 2 mA. The common fault relay and the LED fault indicator are activated.
Err	Calibration Error: More than one channel is in calibration mode. Err displays to notify that only one channel can be set for calibration at one time. Switch Alarm 1 and Alarm 2 of the channels not being calibrated to the OFF position to clear the error message.
MAX	Maximum Gas Level Detected (MGLD): ppm / %LEL / %O ₂ (lowest level detected).
CLr	Maximum Gas Levels Detected (MGLD) are cleared.
	Disabled Audible Alarm Icon: The audible alarm is common to all channels and automatically activates for all channels if an alarm condition occurs. To isolate (disable) a selected channel from the common alarm, set the AUDIBLE switch to OFF.  displays to indicate that the channel is isolated from the common alarm.
CAL	In calibration mode (alternates with zero value of the transmitter).
SPn	Is being spanned (alternates with the span value of the transmitter).

Maintenance

Inspect the controller on a regularly scheduled basis to ensure it is operating normally.

Clean only the exterior of the controller, using mild soap and clean water.

Table 4: Troubleshooting Guide

* Applicable in ordinary location version.

Problem	Possible Cause	Solution
The ac power is activated and the LCD is blank. The LCD backlights are deactivated.	The power slide switch is positioned to OFF.	Position the power slide switch to 110 Vac or 220 Vac, depending upon the voltage of the power source.*
The dc power is activated and the LCD is blank. The backlights are deactivated.	The dc power fuse is blown. The dc power supply has a low current rating and cannot sustain the load of the controller.	Replace the fuse. Replace the external power supply. Ensure the external power supply has a minimum 1.5 A rating.
LCD displays -OC . Fault LED indicator is activated.	The 4-20 mA transmitter is not installed. If installed, the wiring is not secured.	Ensure the transmitter wiring is connected correctly to the terminal block. Secure the wiring from the terminal block.
LCD displays -FC . Fault LED indicator is activated.	The signal from the 4-20 mA transmitter is less than 2 mA. The 4-20 mA transmitter is not calibrated correctly.	If the transmitter does not have zero and span adjustment and will not zero and span using the controller, replace the transmitter. Calibrate the zero and span of the 4-20 mA transmitter.
LCD displays Err .	Attempting to calibrate two or more channels at the same time.	Toggle the L-ALARM and H-ALARM dip switches to OFF for all but the required channel.
LCD displays -OL .	The signal from the 4-20 mA transmitter is over 20 mA.	Wait for the sensor to stabilize (common to any biased sensor, e.g. Ammonia).
High LED, common high alarm, and the relay is activated. The LCD displays less than high alarm trip-point.	High alarm is latched.	Press Reset Alarm ▼ to acknowledge the alarm.
No audible alarm when low or high alarm condition exists. 🔊 icon displays.	The AUDIBLE switch is set to OFF.	Toggle the AUDIBLE switch to the ON position. 🔊 icon no longer displays.
The green dc LED is blinking. Note: This indicates the power supply of the controller is low (below 17 V).	The controller is using an external +24 Vdc supply and the supply can not sustain the load. The controller is using the backup battery and the battery is low.	Replace the external power supply. Ensure the external power supply has a minimum 1.5 A rating. Recharge the battery backup.

Figure 8: Battery Backup Kit Assembly Drawing

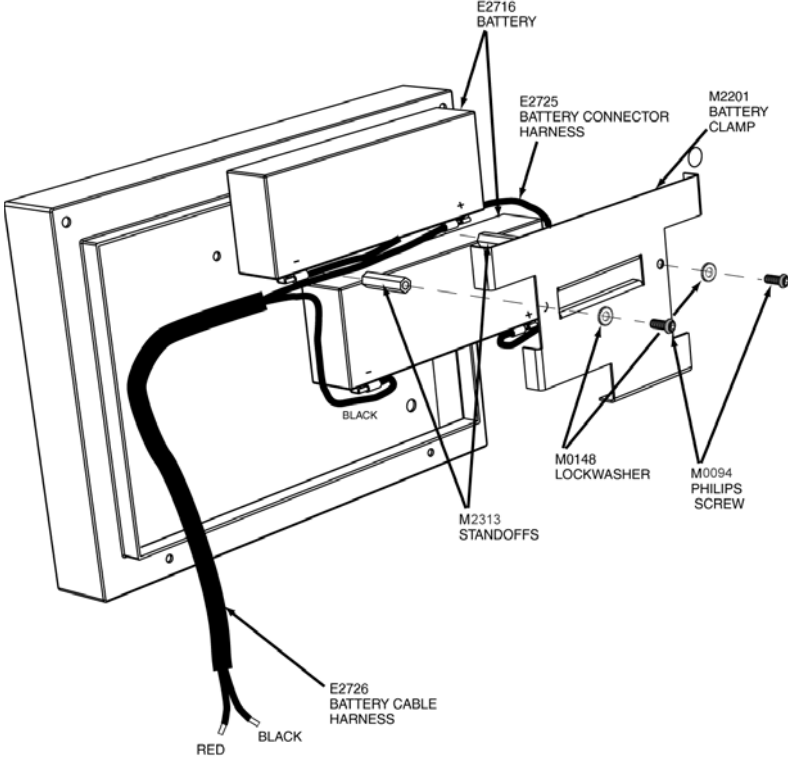

Field Installation

1. Assemble as shown in Figure 8.
2. Refer to page 8 for wiring connections.

Replacing the Batteries

Remove the old batteries as shown in Figure 8. Insert the new batteries and reassemble.

Replacement Batteries: Lead acid 12V, 2.2 Ah only.

Rechargeable Batteries: Panasonic LCR12V2.2P or equivalent. Do not use non-rechargeable batteries.



Note

This instrument contains sealed, lead acid rechargeable batteries. Spent batteries should be disposed of in accordance with local regulations and guidelines.

Table 5. Replacement Parts

Qty.	Description	Part No.
1	Battery Backup Kit <ul style="list-style-type: none"> • 12 V 2.2 Ah rechargeable battery • (2) aluminum hex standoffs • (2) stainless steel lockwashers • (2) Philips screws • Battery cable harness • Battery connector harness 	CR-Bat1

Notes

Specifications

Power:	Field selectable for ac (115V and 230V) or dc (24V)
Electrical Supply:	115 Vac, 0.36 A; 230 Vac 0.18 A; 50/60 Hz; 24 Vdc, 1.5 A
Optional Back-up:	Rechargeable 12 V battery kit supplies approx. 3 hours in normal operation dependant on the draw of each transmitter connected.
Fuse Rating:	250 mA @ 30 watts
Fuse Type:	Resettable (Auto)
Environmental:	
Operating Temperature:	-4 to +122°F (-20 to +50°C)
Relative Humidity:	5 to 99% (non-condensing)
Altitude:	Up to 6,565 ft. (2000m)
Enclosure Rating:	NEMA 12
Physical:	
Dimensions (d x w x h):	2.4 x 13 x 9.5 in. (6 x 33 x 24 cm) approx.
Weight:	4.85 lb. (2.2 kg)
Enclosure:	Enameled Steel RFI/EMI protected
Wire Terminations:	Screw type terminal block
Wiring Ports:	Seven 3/4 in. (22 mm) NPT ports
Mounting:	Wall mounted - equipped with hanging slots and hinged door
Alarms:	Two setpoints - user programmable - with simple rotary switch
Audible:	85 dB buzzer
Relay Outputs:	SPDT Relays
Rated Load:	10 amps at 115 Vac; 8 amps at 230 Vdc amp
Operation Load (Max):	250 Vac; 125 Vdc
Alarm Relays:	Standard: One common low gas alarm, de-energized, non-latching One common high gas alarm, de-energized, latching One common fault, normally energized, non-latching
	Optional: One low gas alarm and one high gas alarm (2) per channel Field selectable energized/de-energized, latching/non-latching; Zoning (Park) function and audible alarm ON/OFF
Display Panel:	Backlit LCDs: Four independent 3-digit alphanumeric status displays %LEL, PPM, or O ₂ % by vol. readouts (field selectable)
	LED Indicators: Alarms: Low (red), high (red), and fault (amber)
	Power: On, ac or dc (green)
	Gas: Concentration icon - ppm, %O ₂ , and %LEL
Controls:	Two large pushbutton controls: Reset Alarm ▼ (acknowledge, peak exposures) Lamp Test ▲ (audible/visual alarm test)
	Alarm Setpoints: Simple up/down buttons
Ratings and Certifications:	
Area Classification:	General Purpose/Class I, Division 2 (under proper installation practices) CE: Declared to electromagnetic compatibility directive and low voltage directive. CAN/CSA C22.2 152 ANSI/ISA –S12.13 Part 1 ANSI/UL 913 C22.2 213 ANSI/ISA S82.01; CAN/CSA C22.2 No. 1010-1
Pollution Degree:	IEC 61010-1
Installation Category:	2
	II
Warranty:	Two years, non-prorated

DUE TO ON-GOING RESEARCH AND PRODUCT IMPROVEMENT, SPECIFICATIONS ARE SUBJECT TO CHANGE WITHOUT NOTICE.

Limited Warranty & Limitation of Liability

BW Technologies LP (BW) warrants this product to be free from defects in material and workmanship under normal use and service for a period of two years, beginning on the date of shipment to the buyer. This warranty extends only to the sale of new and unused products to the original buyer. BW's warranty obligation is limited, at BW's option, to refund of the purchase price, repair, or replacement of a defective product that is returned to a BW authorized service center within the warranty period. In no event shall BW's liability hereunder exceed the purchase price actually paid by the buyer for the Product.

This warranty does not include:

- a) fuses, disposable batteries or the routine replacement of parts due to the normal wear and tear of the product arising from use;
- b) any product which in BW's opinion, has been misused, altered, neglected or damaged by accident or abnormal conditions of operation, handling or use;
- c) any damage or defects attributable to repair of the product by any person other than an authorized dealer, or the installation of unapproved parts on the product; or

The obligations set forth in this warranty are conditional on:

- a) proper storage, installation, calibration, use, maintenance and compliance with the product manual instructions and any other applicable recommendations of BW;
- b) the buyer promptly notifying BW of any defect and, if required, promptly making the product available for correction. No goods shall be returned to BW until receipt by the buyer of shipping instructions from BW; and
- c) the right of BW to require that the buyer provide proof of purchase such as the original invoice, bill of sale or packing slip to establish that the product is within the warranty period.

THE BUYER AGREES THAT THIS WARRANTY IS THE BUYER'S SOLE AND EXCLUSIVE REMEDY AND IS IN LIEU OF ALL OTHER WARRANTIES, EXPRESS OR IMPLIED, INCLUDING BUT NOT LIMITED TO ANY IMPLIED WARRANTY OF MERCHANTABILITY OR FITNESS FOR A PARTICULAR PURPOSE. BW SHALL NOT BE LIABLE FOR ANY SPECIAL, INDIRECT, INCIDENTAL OR CONSEQUENTIAL DAMAGES OR LOSSES, INCLUDING LOSS OF DATA, WHETHER ARISING FROM BREACH OF WARRANTY OR BASED ON CONTRACT, TORT OR RELIANCE OR ANY OTHER THEORY.

Since some countries or states do not allow limitation of the term of an implied warranty, or exclusion or limitation of incidental or consequential damages, the limitations and exclusions of this warranty may not apply to every buyer. If any provision of this warranty is held invalid or unenforceable by a court of competent jurisdiction, such holding will not affect the validity or enforceability of any other provision.



D1355/3 (English)

iERP: 121290

© 2006 BW Technologies, all rights reserved. Printed in Canada.

All product names are trademarks of their respective companies.



Figure 8. Battery Backup Kit Assembly Drawing (p. 18)

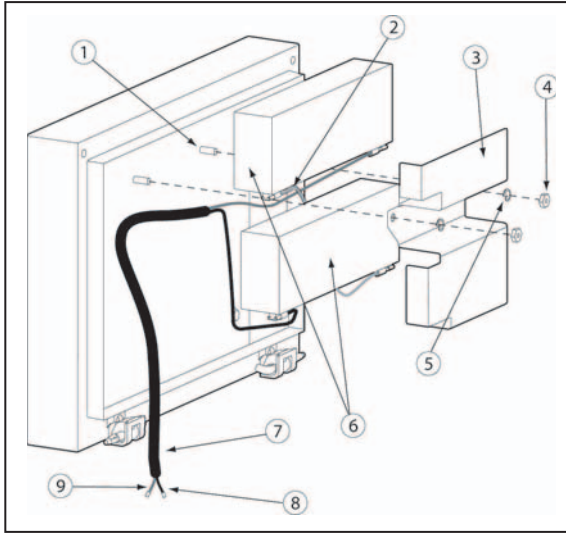
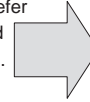

Table 5. Replacement Parts

Item	Description	Model#
1	Studs	N/A
2	Battery connector harness	E2725
3	Battery clamp	M2201
4	Nuts	M0147
5	Lock washer (2)	M0148
6	Battery (2)	E2716
7	Battery cable harness	E2726
8	Black wire	N/A
9	Red wire	N/A

The battery clamp has been modified for the CR-4000. Refer to this revised illustration and table for updated information.



FCC Statement

This equipment has been tested and found to comply with the limits for a Class B digital device, pursuant to Part 15 of the FCC Rules and ICES-003 Canadian EMI requirements. These limits are designed to provide reasonable protection against harmful interference in a residential installation. This equipment generates, uses and can radiate radio frequency energy and, if not installed and used in accordance with the instructions, may cause harmful interference to radio communications. However, there is no guarantee that interference will not occur in a particular installation. If this equipment does cause harmful interference to radio or television reception, which can be determined by turning the equipment off and then on, the user is encouraged to try to correct the interference by one or more of the following measures:

- Reorient or relocate the receiving antenna.
- Increase the separation between the equipment and receiver.
- Connect the equipment into an outlet on a circuit different from that to which the receiver is connected.
- Consult the dealer or an experienced radio/TV technician for help.

Contacting BW Technologies

BW Europe
5 Canada Close
Banbury, Oxfordshire
United Kingdom OX16 2RT
Europe: +44 (0) 1295 700300