

GE
Sensing



HygroPro
Moisture Transmitter

User's Guide



GE
Sensing

HygroPro *Moisture Transmitter*



User's Guide

916-099B
March 2007

The *HygroPro* is a GE Panametrics product. GE Panametrics has joined other GE high-technology sensing businesses under a new name—GE Sensing.



Warranty

Each instrument manufactured by GE Sensing, is warranted to be free from defects in material and workmanship. Liability under this warranty is limited to restoring the instrument to normal operation or replacing the instrument, at the sole discretion of GESensing. Fuses and batteries are specifically excluded from any liability. This warranty is effective from the date of delivery to the original purchaser. If GE Sensing determines that the equipment was defective, the warranty period is:

- one year from delivery for electronic or mechanical failures
- one year from delivery for sensor shelf life

If GE Sensing determines that the equipment was damaged by misuse, improper installation, the use of unauthorized replacement parts, or operating conditions outside the guidelines specified by GE Sensing, the repairs are not covered under this warranty.

The warranties set forth herein are exclusive and are in lieu of all other warranties whether statutory, express or implied (including warranties or merchantability and fitness for a particular purpose, and warranties arising from course of dealing or usage or trade).

Return Policy

If a GE Sensing instrument malfunctions within the warranty period, the following procedure must be completed:

1. Notify GE Sensing, giving full details of the problem, and provide the model number and serial number of the instrument. If the nature of the problem indicates the need for factory service, GE Sensing will issue a RETURN AUTHORIZATION NUMBER (RAN), and shipping instructions for the return of the instrument to a service center will be provided.
2. If GE Sensing instructs you to send your instrument to a service center, it must be shipped prepaid to the authorized repair station indicated in the shipping instructions.
3. Upon receipt, GE Sensing will evaluate the instrument to determine the cause of the malfunction.

Then, one of the following courses of action will then be taken:

- If the damage is covered under the terms of the warranty, the instrument will be repaired at no cost to the owner and returned.
- If GE Sensing determines that the damage is not covered under the terms of the warranty, or if the warranty has expired, an estimate for the cost of the repairs at standard rates will be provided. Upon receipt of the owner's approval to proceed, the instrument will be repaired and returned.

Table of Contents

Introduction	1
Installation	2
Sample System Guidelines.....	2
Insertion into the Sample System/Process.....	4
Standard Wiring Connections.....	5
Digital Communications Wiring Connections	8
Hazardous (Classified) Area Installation	10
Powering Up.....	15
Initial Transmitter Setup.....	16
Accessing the Setup Program	16
Selecting Measurement Formats	17
Setting Up the Display.....	18
Selecting Outputs	19
Preparing for Digital Communications	20
Setting up the RS485.....	21
Additional Setup	21
Setting Up the Pressure/Temperature Readings	21
Entering Sensor Calibration Data	23
Locking/Unlocking the Keypad/Menus	24
Service	26
Troubleshooting	26
Error Handling	27
Maintenance	27
Preparing to Clean the Probe	27
Replacing the RTE.....	28
Removing the Transmitter.....	28
Removing the Probe	28
Soaking the Sensor and Shield.....	30
Installing/Reinstalling the Probe	31
Evaluating the Cleaned Probe	31

Table of Contents (cont.)

Specifications	32
General	32
Electrical	33
Mechanical	33
Moisture Sensor.....	34
Built-In Temperature Sensor.....	35
Built-In Pressure Sensor	35
Certification	36

Introduction

The GE Sensing **HygroPro** Moisture Transmitter is a compact, intrinsically safe, loop-powered, 4-20 mA transmitter that provides accurate dew/frost point measurements covering an overall range of -110° to 20°C (-166° to 68°F). It features an integrated display and a six-button keypad, and is housed in an IP67 / Type 4X enclosure.

The **HygroPro** has an aluminum oxide moisture sensor, a temperature thermistor and a pressure transducer on a single mount for calculation of parameters such as ppm_v in gases, ppm_w in liquids, pounds per million standard cubic feet in natural gas, or process relative humidity.

Installation

Note: *To install the HygroPro in a hazardous (classified) area, see Hazardous (Classified) Area Installation on page 10.*

Sample System Guidelines

The **HygroPro** transmitter can be installed into a sample system or directly into the process. The factory recommends that the unit be installed in a sample system to protect the probe from coming into contact with damaging elements in the process.

Before constructing a sample system, consult a GE Sensing applications engineer and adhere to the guidelines below. See Figure 1 on page 3 for an example of a sample system.

- A sample system should be kept very simple. It should contain as few components as possible and all or most of those components should be located downstream of the measurement location.
- Sample system components should not be made of material that will affect measurement. Most common filters and pressure regulators are not suitable for sample systems because they have wetted parts that may adsorb or release moisture, etc. into the sample system. They may also allow ambient contamination to enter the sample system. If possible, use stainless steel material for all wetted parts.
- The transmitter should be installed perpendicular to the sample inlet. For dimensions and other requirements see *Mechanical Specifications* on page 33.

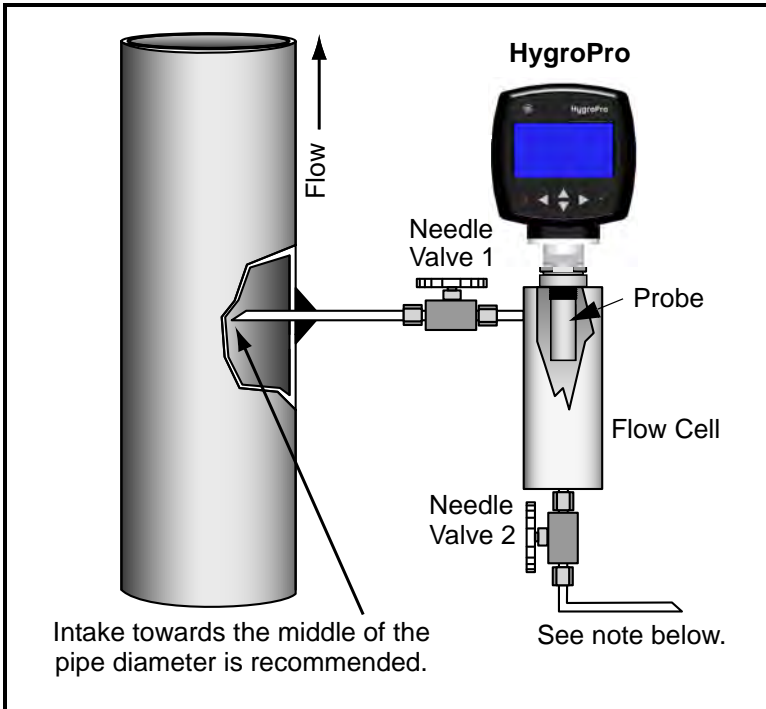

Figure 1: Sample System Example

Note: *At least five feet of 1/4" tubing, if vented to the atmosphere, will ensure the accuracy of the sample in the flow cell and avoid back diffusion of moisture from the ambient air.*

- Sample systems should be leak tested prior to operation, using a Snoop leak detector, to verify the integrity of connections, components and fittings. Tighten any loose fittings.

IMPORTANT: *Caution must be taken when pressurizing or depressurizing the sample system to prevent shock damage to the moisture sensor.*

Note: *If measurement is desired under system pressure, Valve 1 is fully open and the sample flow is regulated by Valve 2.*

If measurement is desired under atmospheric pressure, Valve 2 is fully open and the sample flow is regulated by Valve 1.

Insertion into the Sample System/Process

!CAUTION!

If the HygroPro is being installed directly into the process line, consult the factory for proper installation instructions and precautions before beginning the following procedure.

Use the steps below to install the transmitter:

1. Make sure the sintered or sheet stainless-steel shield is in place. The shield protects the aluminum oxide sensor from damaging elements in the process.
2. The probe is mounted into the process using the 3/4-16 straight male thread located on the probe. Thread the probe end of the transmitter into the process/sample system fitting. Make sure not to cross thread it.

Note: A 3/4-16 to G 1/2 adapter is available from the factory.



Figure 2: HygroPro Installation

Insertion into the Sample System/Process (cont.)

- Using a 1-1/8 in. wrench, tighten the probe securely into the process using the probe hex nut.

!CAUTION!

Do not apply force to the transmitter module to tighten the unit into its fitting.

Note: *If there is insufficient space to rotate the HygroPro during installation, remove the Replaceable Transducer Element (RTE) from the transmitter, install it in the sample system, then install the the transmitter over it.*

Standard Wiring Connections

Note: *To install the HygroPro in a hazardous (classified) area, see Hazardous (Classified) Area Installation on page 10.*

Note: *The HygroPro is a 4-20mA loop powered device, meaning the two-wire supply lines are also the signal lines. The HygroPro is connected either to an external display with power supply and repeater output of 4-20mA, or to a data acquisition system, which provides the loop power and senses the signal representing the selected moisture unit.*

This procedure is for those units not connected to a computer and for those units not requiring hazardous area protection.

The transmitter must be wired using the factory-supplied cable (two meters in length). If an alternate length is required, please contact the factory for assistance.

Note: *If cables need to be lengthened, refer to Table 1 on page 6 to splice an extension onto the existing cable. Connect positive to positive and negative to negative.*

Standard Wiring Connections (cont.)

Use the following steps to wire the transmitter to the system.

1. Push the female connector end on the transmitter cable into the mating male connector on the transmitter module. Make sure the pins are properly aligned. Once inserted, secure the connectors together by sliding the metal sleeve on the cable over the connectors and turning it clockwise until it is tight.
2. Using the flying leads at the other end of the transmitter cable, connect the transmitter to the power supply and data acquisition system (DAS) as shown in Figure 3 on page 7. Refer to Table 1 below for a description of the leads in the factory-supplied cable.

Table 1: Cable Lead Connections for Loop

Lead	Connection Description
Blue	(+) 12 to 28 VDC
Brown	(-) Negative Return
Connecting the shield to earth ground is recommended.	

Note: *The blue and brown leads also draw a current output equivalent to 4 to 20 mA.*

3. Trim any unused leads back to the outer cable jacket in order to remove the bare tinned wire and prevent accidental short circuits.

The **HygroPro** is now ready for operation.

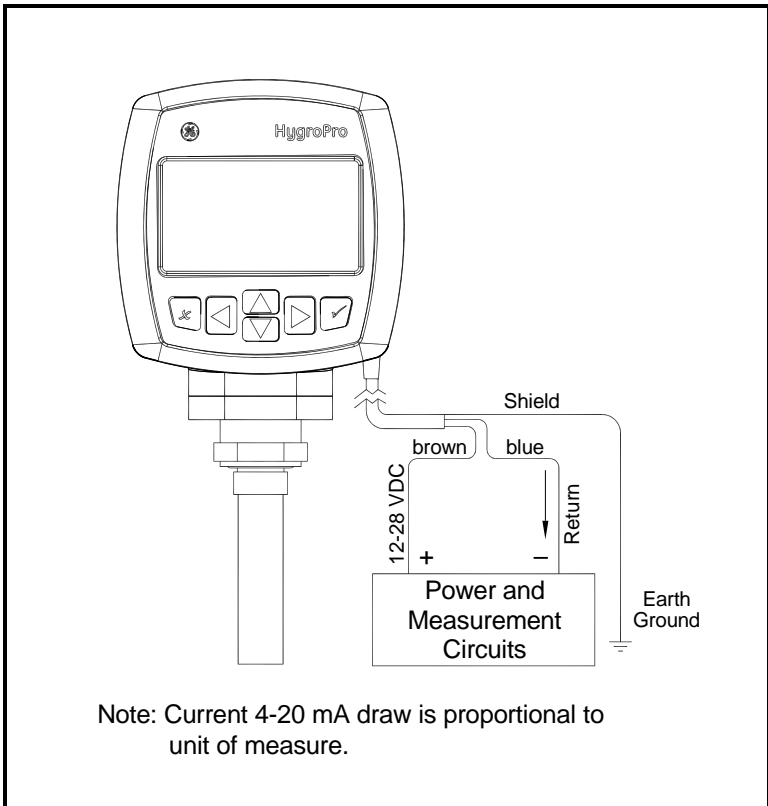

Figure 3: Standard Wiring Connections

Digital Communications Wiring Connections

Note: *To install the HygroPro in a hazardous (classified) area, see Hazardous (Classified) Area Installation on page 10.*

If the unit is to be operated using **PanaView™** instrumentation software installed on a computer, an RS232/RS485 converter must be used and the wiring must be set up as follows.

The transmitter must be wired using the factory-supplied cable (two meters in length).

Note: *If cables need to be lengthened, refer to Table 2 below to splice an extension onto the existing cable. Connect positive to positive, negative to negative, and ground to ground.*

Use the following steps to wire the transmitter to the system.

1. Push the female connector end on the transmitter cable into the mating male connector on the transmitter module. Make sure the pins are properly aligned. Once inserted, secure the connectors together by sliding the metal sleeve on the cable over the connectors and turning it clockwise until it is tight.
2. Using the flying leads at the other end of the transmitter cable, connect the transmitter to the power supply and computer as shown in Figure 4 on page 9. Refer to Table 2 below for a description of the leads in the factory-supplied cable.

Table 2: Cable Lead Connections for RS485

Lead	Connection Description
White	(+) Positive
Black	(-) Negative (return)
Ground	Earth Ground

3. Trim any unused leads back to the outer cable jacket in order to remove the bare tinned wire and prevent accidental short circuits.

The **HygroPro** is now ready for operation.

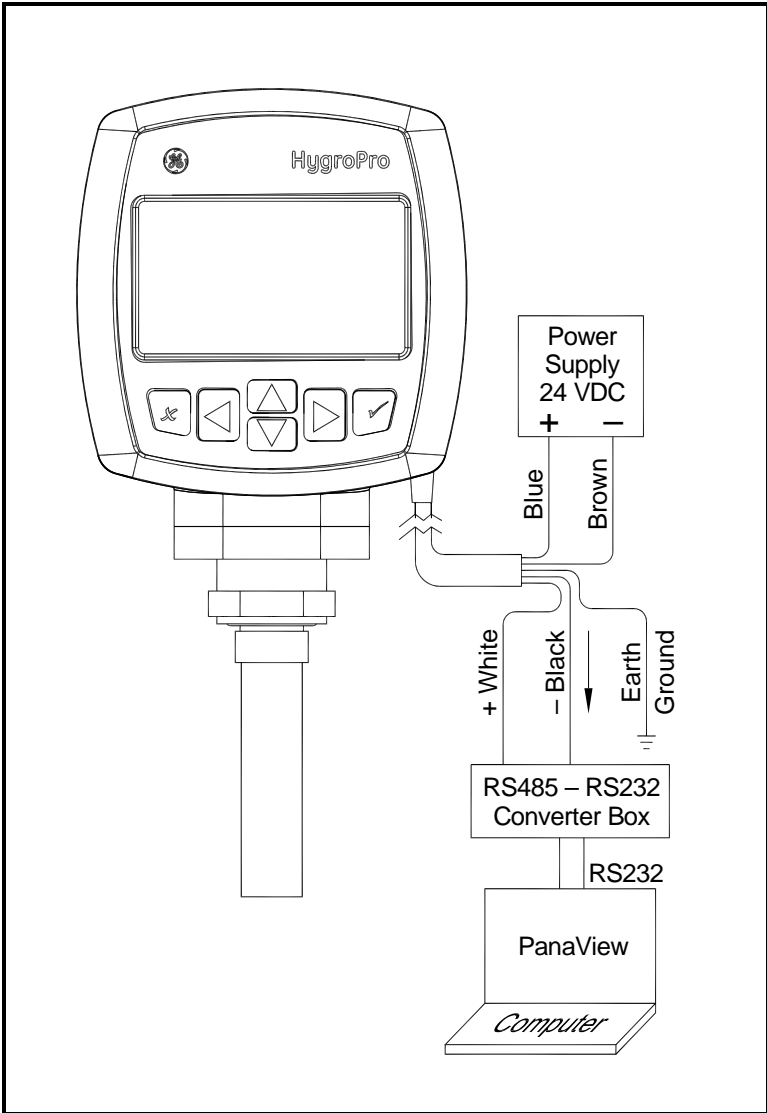

Figure 4: Digital Communications Wiring Connections

Hazardous (Classified) Area Installation

Before installing and using the **HygroPro** in a hazardous (classified) area, be sure to read and understand all the related data. This includes the approval standards and European Norms listed below, all local safety procedures, the FM installation drawing (Figure 5 on page 14), and the first part of this manual.

To install and use the **HygroPro** in potentially explosive atmospheres “hazardous (classified) areas”, use only trained engineers who have the necessary skills and qualifications.

Note: *It is the user's responsibility to apply related standards and methods.*

Installation

The installation must comply with EN 60079-14 in Europe and with the National Electrical Code (ANSI/NFPA 70) or part one of the Canadian Electrical Code (C22.1) as applicable in North America. In other regions local codes may apply in addition.

Parameters and Conditions

HygroPro for use in potentially explosive atmospheres areas complies with the ATEX directive 94/9/EC, North American FM/CSA standards and IEC standards. The applied European standards are:

Table 3: European Standards

Title	Number	Date
General requirements	EN 60079-0	2000
Intrinsic safety “i”	EN 50020	2002
Group II, Category 1G, Zone 0 equipment	EN 60079-26	2004

The North American standards applying are:

Table 4: North American Standards

Title	Number	Date
Electrical Equipment for Use in Hazardous (Classified) Locations General Requirements	Class No. 3600	Nov. 1998
Intrinsically Safe Apparatus and Associated Apparatus for use in Class I, II, & III, Division 1, and Class I, Zone 0 & 1 Hazardous (Classified) Locations	Class No. 3610	Oct. 1999
Electrical Equipment for Measurement, Control and Laboratory Use	Class No. 3810	Jan. 2005
Intrinsically Safe and Non-incendive Electrical for Use in Hazardous Locations	CSA-C22.2 No. 157	1992 Reaffirmed 2002
Safety Requirements for Electrical Equipment for Measurement, Control, and Laboratory Use - Part 1: General Requirements (Adopted IEC 61010-1:2001, MOD) (Tri-National standard, with UL 61010-1 and ISA 82.02.01)	CSA-C22.2 No. 61010-1	July 2004
Degrees of Protection Provided by Enclosures (IP Code)	ANSI/IEC 60529	2004
Degrees of Protection Provided by Enclosures (IP Code)	CSA-C22.2 No. 60529	2005

Electrical Connections

The **HygroPro** is certified intrinsically safe for use in zone 0. An isolated intrinsically safe 24 VDC power supply mounted in the safe area or an isolated zener barrier mounted in the safe area, between a standard 24 VDC power supply and the **HygroPro**, must be used to supply the **HygroPro** loop.

If using the RS485 communication, an isolated RS232/RS485 converter mounted in the safe area between the computer and **HygroPro** must be used. The converter is normally 24 VDC powered from a standard 24 VDC power supply.

!WARNING!

Do not power the converter from the intrinsically safe 24 VDC power supply used for the 4 to 20 mA loop.

Associated Apparatus and Parameters

The total allowable outer capacitance and inductance, when connecting to the associated apparatus, is defined by the manufacturer of the associated apparatus in its data sheet. The output parameters of the associated apparatus i.e. voltage, current and power must be equal or lower than the entity parameters of the HygroPro.

The entity parameters of the **HygroPro** are as follows:

Loop Supply

$U_i = 28V$	$P_i = 0.653W$	$L_i = 62\mu H$
$I_i = 93.3mA$	$C_i = 0$	

RS485

$U_i = 3.72V$	$P_i = 212mW$	$L_i = 62\mu H$
$I_i = 228mA$	$C_i = 67\mu F$ at 5.36V	

Note: *Special conditions for safe use in Europe, will be applicable also to other regions:*

The certificate number Bas06ATEX0019X has an “X” at the end pointing to special conditions. Following these conditions is recommended for other regions outside of Europe.

1. The equipment must be protected against impact or friction with ferrous metals.
2. The bare ends of the connecting cable must be terminated in such a way so as that the terminations are afforded a degree of protection of not less than IP20 ingress protection.

Associated Apparatus and Parameters (cont.)

3. The **HygroPro** is incapable of withstanding the 500 VAC test between all inputs and frame for one minute. Therefore, the **HygroPro** must be earthed connecting the outer grounding screw on the **HygroPro** with the equipotential bonding system. Follow the standards and local electrical codes about the equipotential bonding earthing system.

!WARNING!

Never connect or disconnect the HygroPro in the hazardous area when supply power or the communication circuit is energized. Isolate the supply lines in the non-hazardous area first.

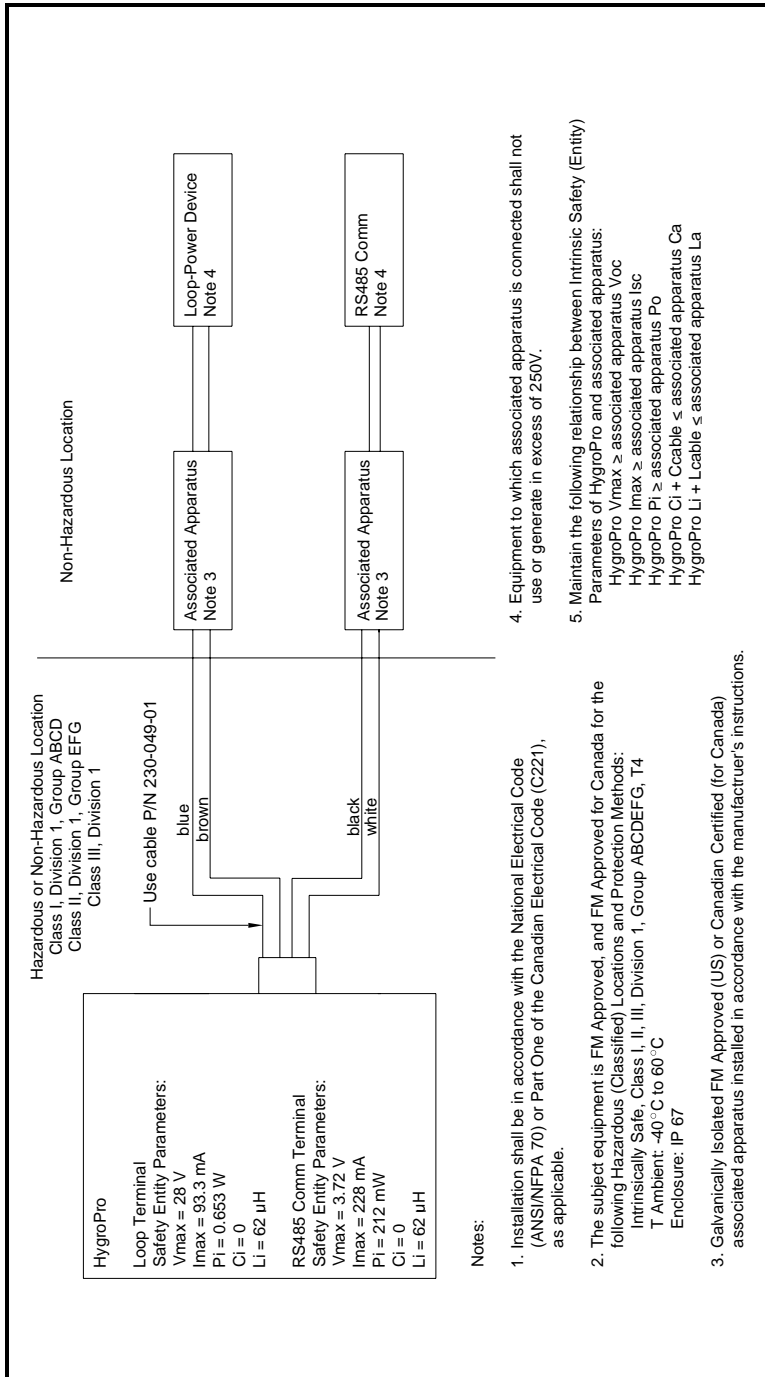

Figure 5: Schematic Diagram (ref. dwg #752-262)

Powering Up

After the **HygroPro** is wired as described in the previous sections, power may be applied to the unit. The transmitter takes up to 60 seconds to initialize and begin normal operation. The unit will meet specified accuracy in 3 minutes.



Figure 6: HygroPro Keypad

Initial Transmitter Setup

After proper installation, the **HygroPro** Transmitter can be set up to accommodate the user's requirements. Refer to the Menu Map, Figure 7 on page 25, and complete the following steps. Upon startup, the following display appears on the screen.

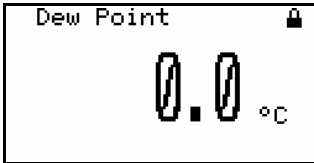

The symbol in the upper right corner indicates that the screen is locked.

To unlock the screen, press



escape, enter, escape.

Note: *In most instances; use the **enter** key to save an entry and/or move ahead to the following screen; use the **escape** key to reject an entry and/or return to the previous screen.*

Accessing the Setup Program

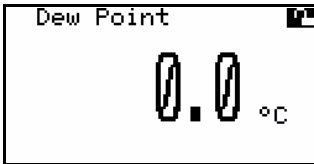

Using the arrow keys, highlight the opened lock and press **enter**. The following screen appears:



Select Passcode and press **enter**. The following screen appears:

Note: *The Operator-Level passcode is 2719.*

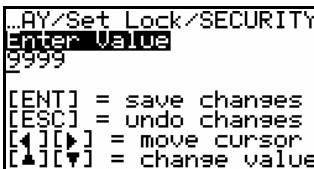

Enter the passcode using the **up** and **down** keys to change the value of each passcode digit, and the **left** and **right** keys to move from one digit to the next.

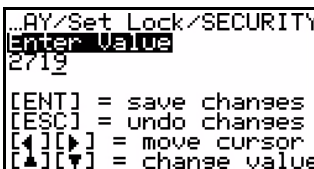

When the passcode is correct, press **enter**, and see the following screen:

Note: *To enter the Service menu, the passcode must be Factory-Level.*

Selecting Measurement Formats

```
[DISPLAY] SENSOR ▶
# of Views...
Display...
```

To program those measurements (hygro, temperature and/or pressure) to be displayed, select # of Views and press **enter**.

```
...ISPLAY/DISPLAY/Views
1 View
2 Views
■ 8 Views
```

Use the **up** and **down** keys to select the number of views desired and press **enter**. Press **enter** again to return to the base menu.

```
Dew Point 0.0 °C M2
Temperature 0.0 °C
Pressure 0.0 PSIa
```

Press **escape** to see the view setup. To change a measurement category, use the arrow keys to highlight that name, press **enter** and a screen similar to the following appears:

```
DISPLAY/Measure
■ Hygro: Dew Point...
Hygro: Rel Humidity
Hygro: H2O...
Hygro: H2O Nat Gas...
Hygro: MMSCF/IG...
Hygro: MMSCF/NG...
▼ Hygro: Vapor Press...
```

Use the **up** and **down** arrow keys to select a measurement category, press **enter** twice. Depending on the category selected, a screen similar to the following appears:

```
DISPLAY/Measure/Unit
■ °F
K...
```

Use the **up** and **down** arrow keys to select a unit of measure and press **enter** twice. Repeat this process to make any other measurement changes.

*If the Service-Level passcode was used, a screen similar to the following appears. If the Operator-Level passcode was used, highlight the lock symbol and press **enter** again to return to the DISPLAY menu.*

```
DISPLAY/Unit/Format
Decimal... 2
```

If the number of decimal points is appropriate, press **escape**. To change the number of decimal points, press **enter** and a screen similar to the following appears:

Selecting Measurement Formats (cont.)

```
DISPLAY/Unit/Format/  
Enter Value  
2  
[ENT] = save changes  
[ESC] = undo changes  
[←][→] = move cursor  
[▲][▼] = change value
```

Use the **up** and **down** keys to change the number of decimal points and press **enter**. The view setup screen reappears.

Setting Up the Display

```
DISPLAY/Set Lock  
Passcode  
Lock Keypad  
Lock Menu
```

The options include: re-entering the Passcode (to access other options), Lock Keypad, and Lock Menu. Use the **up** and **down** keys to select an option and press **enter**.

```
[DISPLAY] SENSOR ▶  
# of Views...  
Display
```

If Passcode was selected, re-enter the passcode and press **enter**. Select Display, press **enter**, and the following screen appears:

```
...PLAY/DISPLAY/Display  
Normal  
Reverse  
Contrast... 38%
```

If the display type is appropriate, press **escape** to return to the base menu. If a Normal or Reverse display is desired, highlight the choice and press **enter**.

Press **enter** again to return to the base menu. To change the display Contrast, highlight the choice and press **enter**.

```
...LAY/DISPLAY/Display/  
Enter Value  
38%  
[ENT] = save changes  
[ESC] = undo changes  
[←][→] = move cursor  
[▲][▼] = change value
```

This screen appears. Use the arrow keys to change the Contrast value and press **enter**. Then press **escape** twice to return to the main screen.

Selecting Outputs

```

[SENSOR] COMMUNICA
Output
CALIBrate...
Const Pressure...
Const Temperature...
    
```

After entering the password, use the **right** arrow key to scroll to Output. Press **enter** and the following screen appears:

```

DISPLAY/SENSOR/OUTPUT
Measure
Type...
Range...
Trim...
    
```

With Measure selected, press the **enter** key and the following screen appears:

```

...SENSOR/OUTPUT/Measure
Hydro %
Hydro °F
Hydro °K
Hydro %
Hydro PPMV
Hydro PPMw
Hydro PPMV
    
```

Use the arrow keys to scroll through options, select the one desired, and press **enter**. Press **enter** again to return to the Output menu. Select Type, press **enter** and the following screen appears:

```

...Y/SENSOR/OUTPUT/Type
4-20mA
NAMUR
Special...
    
```

Select the Type of output and press **enter**. Press **enter** again to return to the Output menu. If Special is chosen, the following screen appears:

```

.../OUTPUT/Type/Special
Zero 0.00mA
Span... 0.00mA
    
```

Select Zero or Span, press **enter** and, using the arrow keys, enter the appropriate value on the next screen. Then press **enter**.

```

...OUTPUT/Type/Special/
Enter Value
0.00mA
[ENT] = save changes
[ESC] = undo changes
[←][→] = move cursor
[↑][↓] = change value
    
```

Once the Zero and Span entries have been made, press escape to return to the Output screen and select Range. Press **enter** and the following screen appears:

Selecting Outputs (cont.)

```
.../SENSOR/OUTPUT/Range
Zero... 0.00°C
Span... 100.00°C
```

Enter range values for Zero and Span, press **escape** to return to the Output screen and select Trim. Press **enter** and the following screen appears:

```
...Y/SENSOR/OUTPUT/Trim
Base Trim... 0.00mA
Span Trim... 0.00mA
%... 100%
Mode...
```

Under the Trim menu, make selections and enter values as above. Under Mode, select Test, to verify outputs, or Normal, for normal operation.

Preparing for Digital Communications

For a description of digital communications wiring, see page 8 and Figure 4 on page 9.

Note: *The Node ID is a unique network identifier that enables the HygroPro to be connected to a multi-drop network when used with PanaView™ instrumentation software.*

```
[COMMUNICATIONS] S▶
Node ID... 16
RS485...
```

After entering the password, use the arrow keys to scroll to Node ID. To change the value, press **enter** and the following screen appears:

```
...PLAY/COMMUNICATIONS/
Enter Value
16
[ENT] = save changes
[ESC] = undo changes
[←][→] = move cursor
[▲][▼] = change value
```

Use the arrow keys to change the Node ID and press **enter**.

Setting up the RS485

```

[COMMUNICATIONS] S
Node ID... 16
RS485...

```

After entering the password, use the arrow keys to scroll to RS485. To change RS485 values, press **enter** and the following screen appears:

```

...COMMUNICATIONS/RS485
Baud Rate...
Parity...
Stop Bits...
Data Bits...

```

To change the Baud Rate, press **enter** and the following screen appears:

```

...IONS/RS485/Baud Rate
2400
4800
• 9600

```

Use the **up** and **down** keys to select the appropriate value and press **enter**. Follow the same procedure to change any of the other categories.

Additional Setup

Setting Up the Pressure/Temperature Readings

The following steps set the status of displayed pressure and temperature readings to Live (changing with the current measurements) or Constant (remaining the same throughout; ignoring the current measurements). If Constant is selected, the desired numerical value must also be set.

```

[SENSOR] COMMUNICA
Output...
CALIBrate...
Const Pressure...
Const Temperature...

```

To set the pressure status, enter the password, then use the arrow keys to scroll to Const Pressure. Press **enter** and the following screen appears:

Setting Up the Pressure/Temperature Readings (cont.)

```
..PLAY/SENSOR/Pressure
Press... 1.23 PSIa
▪ Live Pressure
  Constant Pressure
```

Use the arrow keys to select Live Pressure or Constant Pressure, whichever is desired, and press **enter**. The original screen appears.

```
..PLAY/SENSOR/Pressure
Press... 0.00 PSIa
▪ Live Pressure
  Constant Pressure
```

To enter a pressure constant value, use the arrow keys to select Press... and press **enter**. The following screen appears:

```
..LAY/SENSOR/Pressure/
Enter Value
  0.00 PSIa
[ENT] = save changes
[ESC] = undo changes
[←][→] = move cursor
[↑][↓] = change value
```

Use the arrow keys to enter the desired pressure value. (To enter digits in the tens, hundreds and thousands columns, see the note on page 23.) Press **enter**. A screen appears with the new pressure value.

```
↳[SENSOR] COMMUNICA↳
  Output...
  CALIBrate...
  Const Pressure...
  Const Temperature...
```

To set the temperature value and status, use the arrow keys to scroll to Const Temperature. Press **enter** and the following screen appears:

```
..Y/SENSOR/Temperature
Temp... 0.00 °C
▪ Live Temperature
  Constant Temperatur
```

Use the above procedure to set the temperature status, and (if Constant is selected) to enter the temperature value. Once this is accomplished, the pressure and temperature readings are set for operation.

Entering Sensor Calibration Data

```

┌[SENSOR] COMMUNICA┐
└Output...         ┘
└CALIBrate...     ┘
└Const Pressure...┘
└Const Temperature...┘
    
```

After entering the password, use the arrow keys to scroll to Calibrate. Press **enter** and the following screen appears:

```

...LAY/SENSOR/CALIBrate
└Hygro Curve...     ┘
└Press Curve...    ┘
└CS Table...       ┘
    
```

Select Hygro Curve, Press Curve or CS Table and press **enter**. If Hygro Curve was selected, the following screen appears:

```

...NSOR/CALIBrate/Hygro
└Row1...           ┘
└Row2...           ┘
└Row3...           ┘
└Row4...           ┘
└Row5...           ┘
└Row6...           ┘
└Row7...           ┘
    
```

Make a selection and press **enter**. The following screen appears:

```

...CALIBrate/Hygro/Row1
└DP °C...          ┘
└0.000            ┘
└0                ┘
    
```

Select a unit category and press **enter**. The following screen appears:

```

...ALIBrate/Hygro/Row1
└enter Value      ┘
└0.000           ┘
└[ENT] = save changes
└[ESC] = undo changes
└[←][→] = move cursor
└[↑][↓] = change value
    
```

Use the arrow keys to enter a value. When the value has been entered, press **enter**.

Note: To enter digits in the tens, hundreds and thousands columns, first enter a **9** in the singles column (9.000), then use the left arrow key to move left (_9.000). Repeat the process to move left as required (_99.000). Enter the correct leftmost digit, then use the right arrow key and enter the correct digit in each column to the right.

Continue the process for all Hygro Curve categories until all the required information is entered.

Entering Sensor Calibration Data (cont.)

```
..NSOR/CALIBrate/Hygro
▲ Row13...
  Row14...
  Row15...
  Row16...
SAVE_HYGRO_TABLE?
  Save
  Cancel
```

To save all the information, scroll to the bottom of the Hygro Curve list to SAVE_HYGRO_TABLE?, select Save and press **enter**.

IMPORTANT: *Any changes not saved will be lost!*

Repeat the process for Press Curve and CS Table as desired.

Note: *The CS Table is required only if the user wants to make ppm_w measurements. Consult the factory about which table values to use, based on their application.*

Locking/Unlocking the Keypad/Menus

```
DISPLAY/Set Lock
  Passcode...
  Lock Keypad
  Lock Menus
```

To lock the keypad (prevent it from being used), use the down arrow to select Lock Keypad on the initial screen and press **enter** twice. The keypad is now locked.

To unlock the keypad, simply re-open the program as described on page 16.

```
DISPLAY/Set Lock
  Passcode...
  Lock Keypad
  Lock Menus
```

To lock the menus (prevent them from being changed), use the down arrow to select Lock Menus on the initial screen and press **enter** twice. The menus are now locked.

To unlock the menus, simply re-open the program as described on page 16.

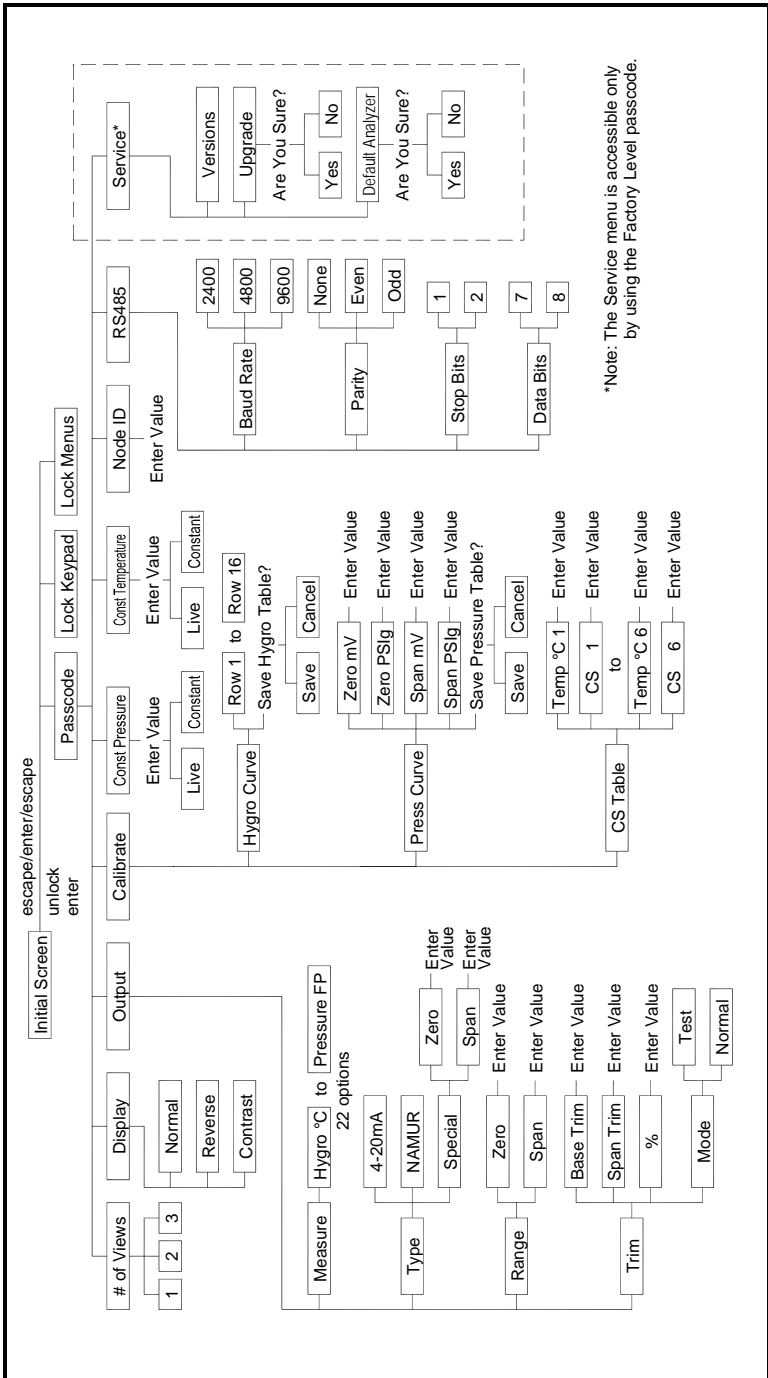

Figure 7: Menu Map

Service

The following information is accessible only by using the Factory-Level passcode.

```
◀ [SERVICE]
  Versions...
  Upgrade...
  Default Analyzer...
```

After entering the Factory Level passcode, use the arrow keys to scroll to Service and press **enter**.

```
© 2005 GE SENSING
S/N: xxxxxxxx
PCI: xxxxxxxx
b: xxx.xxx.x
P: xxx.xxx.x
X: xxx.xxx.x
```

To check the unit version, select Versions and press **enter**. This screen appears with information pertinent to the unit.

```
◀ [SERVICE]
  Versions...
  Upgrade...
  Default Analyzer...
```

To change Service information, select the appropriate category and press **enter**.

```
...PLAY/SERVICE/Confirm
ARE YOU SURE?
  Yes
  No
```

Two of the categories, Upgrade and Default Analyzer ask the question, ARE YOU SURE? To save the entered information, be sure the response selected is Yes.

Upgrade allows a new software upgrade to be loaded into the unit. Default Analyzer will set all programming information to the factory default conditions.

Troubleshooting

Depending on the application, probes may occasionally need to be cleaned. Consult a factory Applications Engineer for required cleaning intervals.

If a problem should arise with the probe, see *Error Handling* below for how the transmitter reacts to error conditions.

Error Handling

In the event of an error condition, the analog output reading is forced to the following values:

- ≥ 22 mA to indicate a shorted probe
- ≤ 3.5 mA to indicate an open probe

Maintenance

If the probe does require cleaning, use the following steps:

Preparing to Clean the Probe

!CAUTION!

Be sure to perform the probe cleaning procedure in a well ventilated area. Observe all necessary safety precautions when handling cleaning solvents

To clean the moisture probe, the following are required:

- Three glass (**NOT** metal) containers containing the following solvents:
 - 2 containers of approximately 300 ml of reagent-grade hexane or toluene each.
 - 1 container of approximately 300 ml of distilled (**NOT** deionized) water.

IMPORTANT: *Make sure the containers are deep enough to submerge the probe. Do not place the transmitter module into the solvents. Insert only the sensor portion of the transmitter into the solvents.*

- Rubber or latex gloves.
- Oven set at $50^{\circ}\text{C} \pm 2^{\circ}\text{C}$ ($122^{\circ}\text{F} \pm 3.6^{\circ}\text{F}$) for drying probe.
- 1-1/8 in. wrench

Use the sections that follow to remove and properly clean the probe.

Note: *Once the probe is clean, dry it in the oven for 24 hours.*

Replacing the RTE

GE Sensing recommends recalibration of the aluminum oxide moisture sensor on the Replaceable Transducer Element (RTE) every 6 to 12 months, depending on the application, to maximize performance. The RTE can be returned to the factory for recalibration and/or a new RTE can be installed. The **HygroPro** electronics will automatically read and store the calibration data when a new or recalibrated RTE is installed.

Note: *Probe calibration data should **not** be changed without consulting the factory.*

Removing the Transmitter

Use the following steps to remove the transmitter from the installation site:

1. Using a 1-1/8 in. wrench, refer to Figure 2 on page 4 and unthread the transmitter from the fitting on the sample system/process using the probe hex nut.
2. Record the dew point of the ambient air.
3. Disconnect the cable from the module.

Removing the Probe

After removing the transmitter from the installation site, remove the probe from the transmitter as follows:

1. Loosen the four captive screws on the bottom of the transmitter.
2. Carefully remove the metal plate without touching the sensor.
3. Carefully pull the probe out of the transmitter.
4. Disconnect the probe cable by turning the locknut at the top of the probe and detach the sensor.

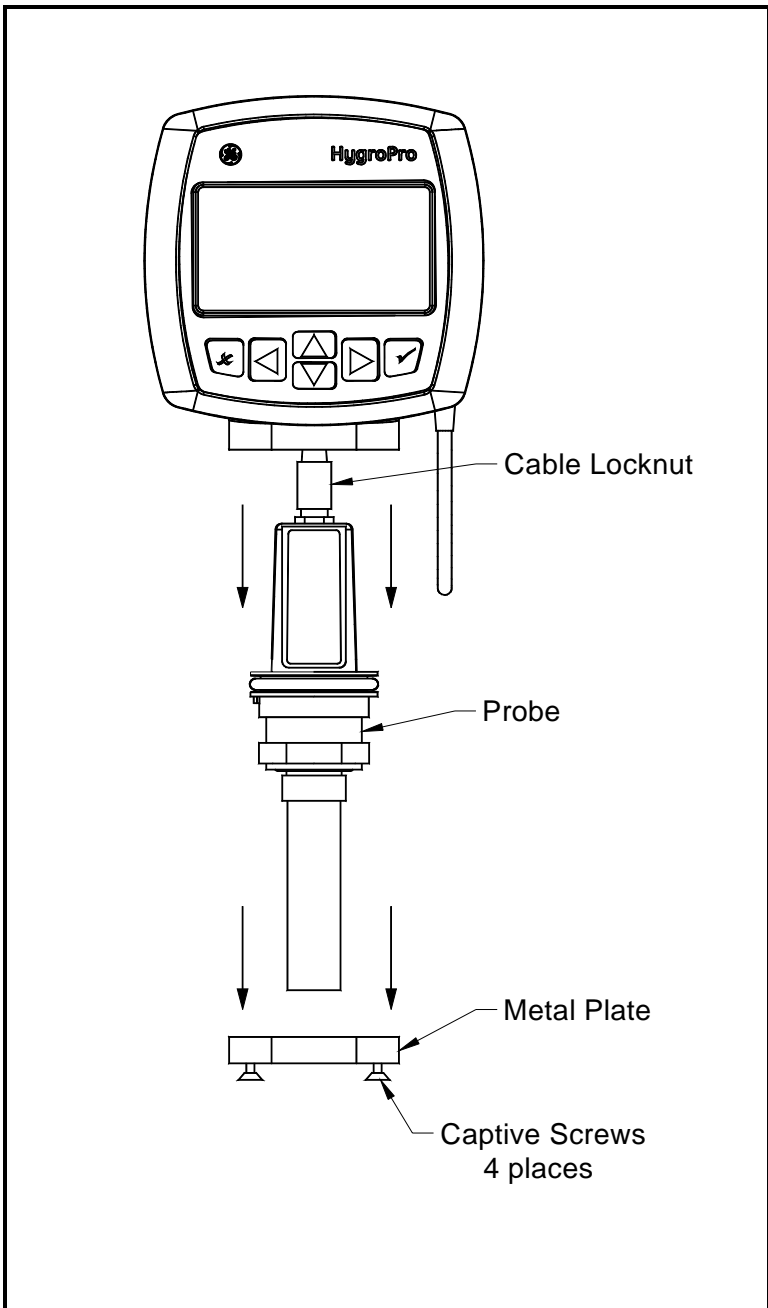

Figure 8: Removing the Probe from the Transmitter

Soaking the Sensor and Shield

!CAUTION!

Do not place the transmitter module into the solvents. Insert only the sensor portion of the instrument. Do not allow the sensor to come into contact with the surfaces of cleaning containers or with any other hard surface.

1. Wearing gloves, place the sensor in the first container of hexane or toluene and allow it to soak for 10 minutes.
2. Remove the sensor from the hexane or toluene and soak it in the container of distilled water for 10 minutes.
3. Remove the sensor from the distilled water and soak it in the second (clean) container of hexane or toluene for 10 minutes.
4. Remove the sensor from the hexane or toluene and set it aside until the shield has completed the cleaning cycle.
5. Repeat steps 1 to 3, above, to clean the shield. To ensure the removal of any contaminants that may have become embedded in the porous walls of the shield, swirl the shield in the solvents during the soaking procedure.
6. Remove the shield from the hexane or toluene.
7. Carefully replace the shield over the exposed sensor without touching it.
8. Place the sensor with the shield in an oven set at $50^{\circ}\text{C} \pm 2^{\circ}\text{C}$ ($122^{\circ}\text{F} \pm 3.6^{\circ}\text{F}$) for 24 hours.

Installing/Reinstalling the Probe

If a new probe is being installed, or after the sensor and shield has been cleaned:

1. Reconnect the probe cable by turning the locknut onto the top of the probe.
2. Carefully push the probe into the transmitter.
3. Replace the metal plate without touching the sensor.
4. Tighten the four captive screws on the metal plate into the bottom of the transmitter.

Evaluating the Cleaned Probe

Note: *A new probe will have been calibrated at the factory, and will adjust the transmitter accordingly.*

1. Re-connect the cable to the transmitter module and measure the dew point. Make sure to measure the same ambient air as measured in step 2 under *Remove the Transmitter* on page 28.
2. Compare the two ambient air readings. If the new ambient air reading is within $\pm 2^{\circ}\text{C}$ ($\pm 3.6^{\circ}\text{F}$) of the first reading, the cleaned probe is properly calibrated. If not, proceed to step 3 below.
3. If the probe is still not reading the ambient air accurately, repeat the cleaning procedure using soaking times that are five times the previous cleaning sequence, until two consecutive ambient air readings are identical.

If the above cleaning procedure does not result in accurate readings, contact the factory for assistance.

Specifications

General

Dew Point/Frost Point Calibration Range

- 68° to -112°F (20° to -80°C)

Operating Temperature:

- -4° to 140°F (-20° to 60°C)

Storage Temperature:

- 158°F (70°C) maximum

Warm-Up Time

- Meets specified accuracy in three minutes

Calibrated Accuracy

- $\pm 3.6^\circ\text{F}$ ($\pm 2^\circ\text{C}$) from -85° to 50°F (-65° to 10°C) dew/frost point
- $\pm 5.4^\circ\text{F}$ ($\pm 3^\circ\text{C}$) from -112° to -86°F (-80° to -66°C) dew/frost point

Repeatability

- $\pm 0.9^\circ\text{F}$ ($\pm 0.5^\circ\text{C}$) from -85° to 104°F (-65° to 40°C) dew/frost point
- $\pm 1.8^\circ\text{F}$ ($\pm 1.0^\circ\text{C}$) from -112° to -86°F (-80° to -66°C) dew/frost point

Response Time

- Less than five seconds for 63% of a step change in moisture content in either wet-up or dry-down cycle

Electrical

Power

- 12 to 28 VDC (loop-powered, customer supplied)
- Output: 4 to 20 mA analog, RS485 digital
- Output Resolution: 0.01 mA/12 bits
- Maximum Load Resistance (Ω) = $(PSV \times 33.\overline{33}) - 300$
where PSV = Power Supply Voltage

Example: Given a 24 VDC Power Supply,

$$\text{Max. Load Resistance} = (24 \times 33.\overline{33}) - 300 = 500 \Omega$$

- Cable: 6 ft (2 m), standard (consult factory for custom lengths)

Input Parameters for Intrinsic Safety

Loop Supply		
$U_i = 28V$	$P_i = 0.653W$	$L_i = 62\mu H$
$I_i = 93.3mA$	$C_i = 0$	
RS485		
$U_i = 3.72V$	$P_i = 212mW$	$L_i = 62\mu H$
$I_i = 228mA$	$C_i = 67\mu F$ at 5.36V	

Mechanical

Sample Connection

- 3/4-16 (19 mm) straight male thread with O-ring
- G ½ with optional adapter

Operating Pressure

- 5 μ m Hg to 5,000 psig (345 bar)

Enclosure

- Type 4x / IP67

Dimensions

- Overall (H x W x D):
7.88 x 3.99 x 2.56 in. (200 x 101 x 65 mm)
- Weight: 1.2 lb (550 g)

Moisture Sensor

Sensor Type

Thin-film aluminum oxide moisture sensor probe

Calibration

Each sensor is individually computer-calibrated against known moisture concentrations, traceable to NIST

Calibration Interval

Sensor recalibration at GE Sensing is recommended every six to twelve months depending on application

Flow Rate

- *Gases*: Static to 100 m/s linear velocity at a pressure of 1 atm.
- *Liquids*: Static to 10 cm/s linear velocity at density of 1 g/cc

Built-In Temperature Sensor

Type:

- Nonlinear NTC thermistor (resultant temperature linearized by microprocessor)

Measurement Range

- -22° to 158°F (-30° to 70°C)

Accuracy

- $\pm 0.9^{\circ}\text{F}$ ($\pm 0.5^{\circ}\text{C}$) overall

Response Time (Maximum)

- One second in well stirred oil, or 10 seconds in still air, for a 63% step change in increasing or decreasing temperature

Built-In Pressure Sensor

Type

- Solid state/piezoresistive

Available Range

- 30 to 300 psig (3 to 21 bar)
- 50 to 500 psig (4 to 35 bar)
- 100 to 1000 psig (7 to 69 bar)
- 300 to 3000 psig (21 to 207 bar)
- 500 to 5000 psig (35 to 345 bar)

Note: *Psig ranges based on constant pressure, provided at time of order placement.*

Accuracy

- $\pm 1\%$ of full scale (FS)

Warm-up Time

- Meets specified accuracy in 3 minutes

Pressure Rating

- Three times the span of the available range to a maximum of 7500 psig (518 bar)

Certification

European Compliance

- Complies with EMC Directive 89/336/EEC and PED 97/23/EC for DN<25



Figure 9: HygroPro Certification Label - Rear View

We,

GE Sensing
1100 Technology Park Drive
Billerica, MA 01821
USA

declare under our sole responsibility that the

HygroPro™ Moisture Transmitter

to which this declaration relates, are in conformity with the following standards:

- EN 61326:1997+A1+A2

following the provisions of the 89/336/EEC EMC Directive.

The units listed above and any sensors and ancillary sample handling systems supplied with them do not bear CE marking for the Pressure Equipment Directive, as they are supplied in accordance with Article 3, Section 3 (sound engineering practices and codes of good workmanship) of the Pressure Equipment Directive 97/23/EC for DN<25.

November 27, 2006
Date of Issue



Mr. Gary Kozinski
Certification & Standards, Lead Engineer





USA

1100 Technology Park Drive
Billerica, MA 01821-4111
Web: www.gesensing.com

Ireland

Sensing House
Shannon Free Zone East
Shannon, Co. Clare

