



*Moisture Monitor
Series 35 IS*



Process Control Instruments

Moisture Monitor Series 35 IS

User's Manual

910-182B1



GE Panametrics

Warranty

Each instrument manufactured by GE Panametrics is warranted to be free from defects in material and workmanship. Liability under this warranty is limited to restoring the instrument to normal operation or replacing the instrument, at the sole discretion of GE Panametrics. Fuses and batteries are specifically excluded from any liability. This warranty is effective from the date of delivery to the original purchaser. If GE Panametrics determines that the equipment was defective, the warranty period is:

- one year from delivery for electronic or mechanical failures
- one year from delivery for sensor shelf life

If GE Panametrics determines that the equipment was damaged by misuse, improper installation, the use of unauthorized replacement parts, or operating conditions outside the guidelines specified by GE Panametrics, the repairs are not covered under this warranty.

The warranties set forth herein are exclusive and are in lieu of all other warranties whether statutory, express or implied (including warranties or merchantability and fitness for a particular purpose, and warranties arising from course of dealing or usage or trade).

March 2003

Table of Contents

Chapter 1: Features & Capabilities

The Electronics Unit	1-2
Moisture Probes	1-3
The Sample System	1-3
The User Program	1-4

Chapter 2: Installing the Series 35 IS

Choosing a Measurement Site	2-2
Moisture Probe Considerations	2-3
Sample System Guidelines	2-5
Mounting an External Sample System	2-6
The Self-Contained Sample System	2-7
Installing a Probe into a Sample System	2-8
External Sample System	2-8
Self-Contained Sample System	2-10
Making External Probe Connections	2-11
Using Modified or Non-GE Panametrics Cables	2-14
Performing a Calibration Adjustment	2-15

Table of Contents (cont.)

Chapter 3: Operating the Series 35 IS

Getting Started	3-2
Starting Up and Shutting Down the Sample System	3-3
Powering Up the Series 35 IS	3-4
Using the Keypad to Enter and Change Data	3-5
How to Use the Programming Keys.	3-5
How to Enter and Exit the User Program.	3-6
How to Move Through the User Program	3-7
How to Enter Numeric Data.	3-8
Verifying and Changing Factory Setup Data	3-9
Entering the Dew Point Range.	3-10
Entering Calibration Data	3-11
Entering the Probe Serial Number	3-12
Entering High and Low Reference Values.	3-13
Changing the Measurement Display.	3-14
Entering an Offset Value for Dew/Frost Point	3-15
Entering a Constant Pressure Value	3-16
Entering a PPMv Constant Multiplier	3-18
Entering an Interval for Automatic Calibration	3-19
Viewing the Battery Status	3-21
Entering a Backlight-On Time Interval	3-22
Setting Up Computer-Enhanced Response.	3-23
Setting Up Range Error Processing	3-25
Selecting AC Line Frequency (60/50 Hz)	3-26
Adjusting the Contrast	3-27
Setting the Clock Values.	3-28
Setting Up the Data Logger	3-30
Setting the Data Logger Time Interval.	3-31
Entering the Parameter(s) to Log.	3-32
Viewing Log Status, Summary and Data.	3-34
Using the Built-In RS232 Interface	3-39
Dumping Logged Data Via the RS232 Interface.	3-41

Table of Contents (cont.)

Chapter 4: Troubleshooting and Maintenance

Common Problems	4-1
Screen Messages	4-5
Calibration Error Processing	4-7
Recharging and Replacing the Battery	4-8
Recharging the Battery	4-9
Replacing the Battery	4-10
Replacing the User Program	4-13
Removing the Circuit Board	4-14
Replacing the EPROM	4-17
Replacing the Circuit Board	4-19
Replacing and Recalibrating the Moisture Probe	4-20

Chapter 5: Specifications

Electrical Specifications	5-2
General Specifications	5-3

Table of Contents (cont.)

Appendix A: Application of the Hygrometer

Moisture Monitor Hints	A-2
Pressure	A-4
Response Time	A-5
Temperature	A-5
Flow Rate	A-6
Contaminants	A-7
Non-Conductive Particulates	A-7
Conductive Particulates	A-8
Corrosive Particulates	A-8
Aluminum Oxide Probe Maintenance	A-9
Corrosive Gases And Liquids	A-11
Materials of Construction	A-12
Calculations and Useful Formulas in Gas Applications .	A-13
Nomenclature	A-13
Parts per Million by Volume	A-14
Parts per Million by Weight	A-15
Relative Humidity	A-15
Weight of Water per Unit Volume of Carrier Gas . .	A-16
Weight of Water per Unit Weight of Carrier Gas . .	A-16
Comparison of PPMV Calculations	A-26
Liquid Applications	A-27
Theory of Operation	A-27
Moisture Content Measurement in Organic Liquids	A-27
Empirical Calibrations	A-34
Solids Applications	A-40

Appendix B: Outline and Installation Drawings

Appendix C: Menu Map

Appendix D: Data Information Sheet

Series 35 IS Data Information Sheet	D-2
---	-----

Appendix E: Series 35 IS Hygrometer Spare Parts List

Chapter 1

Features & Capabilities

The Series 35 IS, a microprocessor-based, single-channel hygrometer, measures moisture content in gases. The Series 35 IS is suitable for use in a wide range of process conditions requiring real-time moisture measurement. It measures dew/frost points over a temperature range of -110 to $+60^{\circ}\text{C}$ (-166 to $+140^{\circ}\text{F}$).

The following topics are discussed in this chapter:

- The Electronics Unit [page 1-2]
- Moisture Probes [page 1-3]
- The Sample System [page 1-3]
- The User Program [page 1-4]

The Electronics Unit

The Series 35 IS portable moisture monitor is available in two configurations:

- with a self-contained sample system
- without a self-contained sample system.

Both Series 35 IS configurations display measurement data on a one-line, 16-character alpha-numeric LCD display screen. All probe information is entered into the unit using the programming keys on the front panel keypad (see Figure 1-1 below). The Series 35 IS operates on an internal 6 VDC battery, and the unit can operate while being charged with a 12 VDC charger.

Caution!

Do not use AC power in hazardous areas. Charge the battery only in a non-hazardous area.

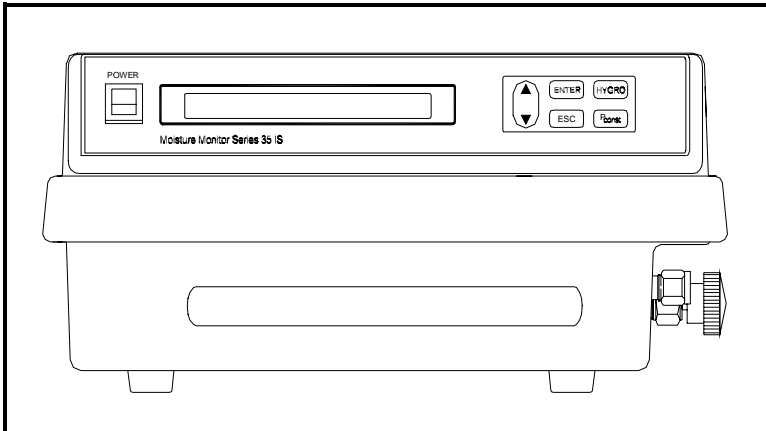

Figure 1-1: Series 35 IS Front Panel

Moisture Probes

The moisture probe is the part of the system that comes in contact with the process, and is usually installed in a sample system. The Series 35 IS uses any M Series probe to measure dew point temperature in °C or °F. A sensor assembly is secured to the probe mount and protected with a sintered stainless steel shield (see Figure 1-2 below). Other types of shields are available.

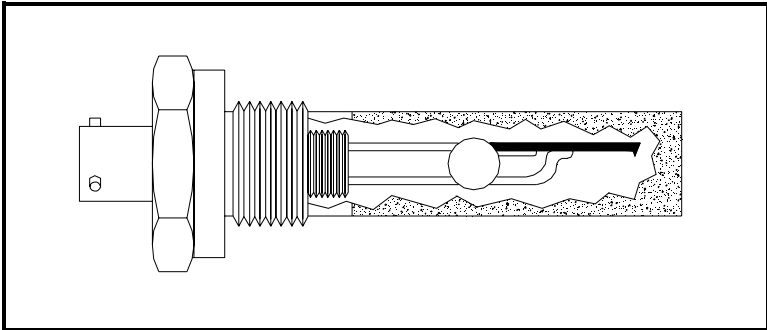

Figure 1-2: The M Series Probe

The Sample System

The sample system conditions or controls a sample stream to the specifications of the measurement probe. Typically, the sample system is kept very simple, with as few components as possible located upstream of the measurement probe. The sample system may include a filter to remove particulates from the sample stream and/or a pressure regulator to reduce or control the pressure of the sample stream. In general, stainless steel is the preferred material for all the sample system's wetted parts.

If it was specified at the time of purchase, your Series 35 IS will include a self-contained sample system.

The User Program

The Series 35 IS contains a user program that enables you to change moisture calibration data and select a number of user-defined program functions.

All functions and features of the Series 35 IS user program are discussed in Chapter 3, *Operating the Series 35 IS*.

Chapter 2

Installing the Series 35 IS

This chapter discusses installing the Series 35 IS in all its configurations. Use the following list of procedures to help you install your unit.

Depending on the type of unit you have, refer to the appropriate section(s) that follow to install your Series 35 IS correctly.

Installing your Series 35 IS consists of the following procedures:

- Choosing a Measurement Site [page 2-2]
- Moisture Probe Considerations [page 2-3]
- Sample System Guidelines [page 2-5]
- Mounting an External Sample System [page 2-6]
- The Self-Contained Sample System [page 2-7]
- Installing a Probe into a Sample System [page 2-8]
- Making External Probe Connections [page 2-11]

Proceed to the appropriate section to install your Series 35 IS.

Choosing a Measurement Site

You should have discussed environmental factors with a GE Panametrics applications engineer or field sales person before you receive your Series 35 IS. The equipment should be suited to both the application and the measurement site.

Read the following guidelines to verify that you have selected the best measurement site.

- Choose a measurement site for the probe and sample system as close to the process line as possible. Avoid long lengths of connecting tubing. If long distances are unavoidable, a fast-sampling bypass loop is recommended.
- Do not install any other components, such as filters, upstream of the probe or sample system unless instructed to do so by GE Panametrics. Many common components, such as filters and pressure regulators, are not suitable for sample systems. These components contain wetted parts that may absorb or release materials (e.g., moisture) into the sample stream or allow ambient contamination to enter the sample stream. In general, use stainless-steel for all parts in contact with the sample.
- Observe all normal safety precautions. Use the probes within their maximum pressure and temperature ratings.
- Do not expose the electronics unit to high temperatures, strong electrical transients, mechanical vibrations, corrosive atmospheres, or any other conditions that could damage or interfere with the Series 35 IS operation. See Chapter 5, *Specifications*, for limits.
- If you are using an external sample system, you should observe the proper cable restrictions for the probes. The M Series probes require specially shielded cable. For units with separate sample systems, you can locate the M Series probes up to 100 meters (330 feet) from the Series 35 IS.
- Protect the probe cables from excessive strain (bending, pulling, twisting, etc.). In addition, do not subject the cables to temperatures above 65°C (149°F) or below -50°C (-58°F).

Moisture Probe Considerations

The M Series probes consist of an aluminum oxide sensor located on a connector and covered by a protective stainless-steel shield.

The probe sensor materials and housing maximize durability and minimize water absorbing surfaces in the vicinity of the aluminum oxide surface. A sintered stainless-steel shield protects the sensor from high flow rates and particulate matter (other shields are available). Do not remove the shield except upon advice from GE Panametrics.

The sensor design permits the device to withstand normal shock and vibration. Be sure to avoid touching the active sensor surface or allowing it to come into direct contact with foreign objects. Such contact may adversely affect performance.

Observing these precautions should ensure a long and useful probe life. GE Panametrics recommends that you check probe calibration routinely, at one-year intervals, or as recommended by the applications engineers for your particular application.

Because the probe measures water vapor pressure in its immediate vicinity, proximity to the system walls, materials of construction, and other environmental factors can influence readings. You can operate the sensor under vacuum or pressure and under dynamic or static conditions. Observe the following environmental precautions.

- 1. Temperature Range:** the standard probe is operable from -110°C to $+70^{\circ}\text{C}$ (-166°F to $+158^{\circ}\text{F}$).
- 2. Moisture Condensation:** be sure the temperature is at least 10°C higher than the dew/frost point temperature. If this condition is not maintained, moisture condensation could occur on the sensor or in the sample system and cause reading errors. If reading errors occur, refer to “Aluminum Oxide Probe Maintenance” in Appendix A.

Moisture Probe Considerations (cont.)

3. **Static or Dynamic Use:** the sensor performs equally well in still air or where considerable flow occurs. Its small size makes it ideal for measuring moisture conditions within completely sealed containers or dry boxes. It also performs well under gas flow linear velocities as high as 10,000 cm/sec, and liquid flow linear velocities to 10 cm/sec. Refer to Tables A-2 and A-3 in Appendix A for maximum gas and liquid flow rates.
4. **Pressure:** the moisture probe always senses the existing water vapor pressure regardless of the total ambient pressure. The moisture sensor measures water vapor under vacuum or high pressure conditions from as little as a few microns Hg to as high as 5000 psi total pressure.
5. **Long-Term Storage & Operational Stability:** continuous abrupt humidity changes do not affect the sensor, and exposure to saturation conditions does not damage the sensor, even when stored.
6. **Freedom from Interference:** the presence of a wide variety of gases or organic liquids does not affect the sensor. Also, large concentrations of hydrocarbon gases, Freon®, carbon dioxide, carbon monoxide, and hydrogen do not affect sensor water vapor indications. The sensor functions properly in a multitude of gaseous or non-conductive liquid environments.
7. **Corrosive Materials:** avoid all materials that are corrosive or otherwise damaging to aluminum or aluminum oxide. These include strongly acidic or basic materials and primary amines.

Sample System Guidelines

A sample system, although not mandatory, is highly recommended for moisture measurement. The purpose of a sample system is to condition or control a sample stream to within the specifications of the probe. The application requirements determine the design of the sample system. GE Panametrics applications engineers can make recommendations based on the following general guidelines:

- Typically, keep the sample system simple. Include as few components as possible and locate all or most of the components downstream of the measurement probe. A simple sample system consists of an explosion-proof housing with a sample cell, a filter, and inlet and outlet needle valves.
- Do not use any material for sample system components that can affect measurements. A sample system may include a filter to remove particulates from the sample stream and/or a pressure regulator to reduce or control the pressure of the stream. However, most common filters and pressure regulators are not suitable for sample systems because their wetted parts may absorb or release components (such as moisture) into the sample stream. They may also allow ambient contamination to enter the sample stream. In general, use stainless-steel for all wetted parts.

Note: *The actual sample system design depends on the application requirements.*

Mounting an External Sample System

Note: *If you have a Series 35 IS with a self-contained sample system, disregard this section and proceed to The Self-Contained Sample System on page 2-7.*

The sample system is usually fastened to a metal plate that has four mounting holes. GE Panametrics can provide the sample system in an enclosure, if requested. Sample system outline and dimension drawings are included in your shipment, if you ordered them.

Use the following steps to mount the external sample system and connect it to the process:

1. Fasten the sample system plate or enclosure to a solid stable surface with bolts and washers in each of its four corners.
2. Connect the process supply and return lines to the sample system inlet and outlet using the required stainless-steel fittings and tubing.

Caution!

Do not start a flow through the system until the probe has been properly installed.

Note: *For common applications, GE Panametrics can provide a standard sample system. If applicable, additional instructions on how to start up and shut down the sample system may be included.*

The Self-Contained Sample System

The Portable Series 35 IS can include a self-contained sample system as shown in Appendix B. This sample system is constructed with 1/4" Swagelok® inlet and outlet compression fittings and 1/4" stainless-steel tubing.

The sample system also includes inlet and outlet needle valves and a 7-micron sintered stainless-steel filter with a replaceable element. All wetted parts are Series 300 stainless steel, Viton®, or Teflon®. The maximum allowable pressure for the sample system is 4500 psig. See Figure 2-1 below.

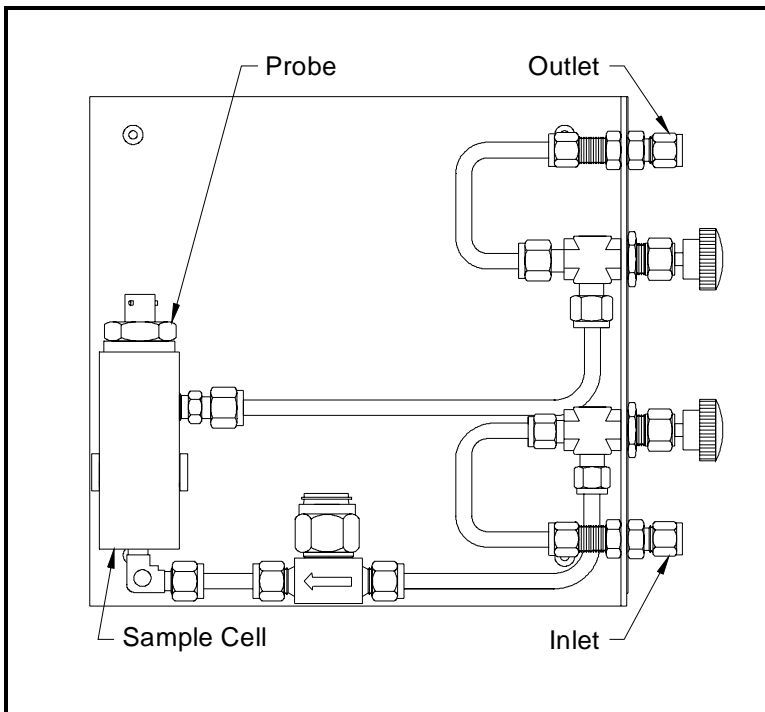

Figure 2-1: Self-Contained Sample System with Probe

Swagelok is a registered trademark of Crawford Fitting Company.
Teflon is a registered trademark of E.I. du Pont de Nemours and Company, Inc.
Viton is a registered trademark of DuPont Dow Elastomers, L.L.C.

Installing a Probe into a Sample System

The sample system design protects the aluminum oxide moisture probe from particulates and is recommended for process gases such as dry instrument/plant air or other similar process gas. Other sample handling equipment (pressure regulators, cooling coils, additional filters, pressure gauges, rota-meters, etc.) may be required for some applications. Contact GE Panametrics or see Appendix A for general information about using GE Panametrics' Aluminum Oxide Moisture Probe. Proceed to the appropriate probe installation section for your system.

Caution!

If you mount the probe directly into the process line, consult GE Panametrics for proper installation instructions and precautions.

External Sample System

Use the following steps to install the probe into the external sample cell. Refer to Figure 2-2 below.

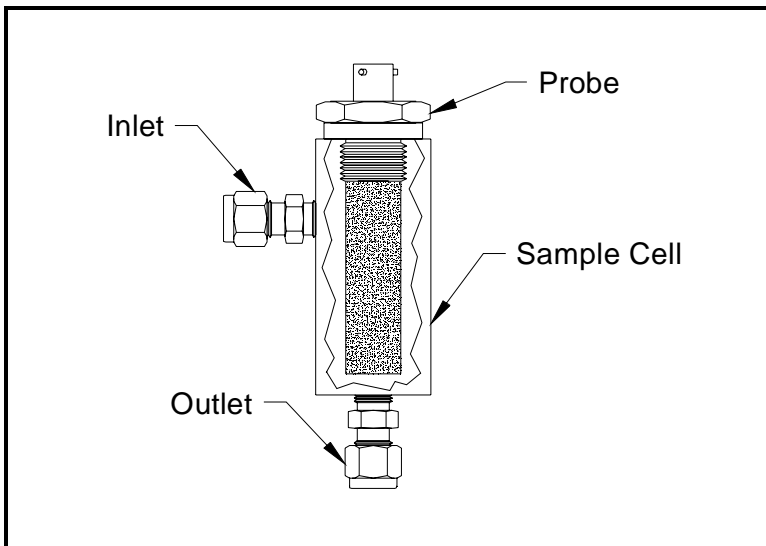

Figure 2-2: A Typical Probe Installation

External Sample System (cont.)

1. Insert the probe into the sample cell so that it is perpendicular to the sample inlet.

IMPORTANT: *For maximum protection of the aluminum oxide sensor, always leave the shield in place.*

2. Screw the probe into the receptacle fitting, making sure not to cross the threads.

Note: *M2 probes have 3/4-16 straight threads with an o-ring seal for installation either into the sample system or directly into the process line. Other mounts are available for special applications.*

3. Hand-tighten the probe in a clockwise direction, then tighten it an additional 1/8 turn with a wrench.

Figure 2-2 on page 2-8 shows a typical probe installation with the probe mounted into a sample cell.

Self-Contained Sample System

Use the following steps to install the probe into the sample cell of a self-contained sample system:

1. Loosen the two quarter-turn screws on the back of the Series 35 IS cover.
2. Remove the cover by gently lifting it off the unit from back to front. Be careful not to pull on the cables that connect to the cover.
3. Insert the probe into the sample cell.
4. Screw the probe into the receptacle fitting, making sure not to cross the threads.

Note: *Insert the probe into the cylindrical shaped container called the sample cell, which is included as part of your sample system. M2 probes have 3/4-16 straight threads and an o-ring seal for installation of the probe into the standard sample cell (see Figure 2-1 on page 2-7).*

5. Hand-tighten the probe in a clockwise direction, then tighten it an additional 1/8 turn with a wrench.
6. Connect the blue probe cable to the probe by inserting the bayonet-type connector onto the probe and twisting the shell clockwise until it snaps into a locked position.

Note: *The connector on the probe cable must be rotated until it aligns with the pins in the probe connector, before the cable may be properly inserted into the probe and secured.*

7. Close the Series 35 IS cover and tighten the two quarter-turn screws on the back of the cover.

Making External Probe Connections

Probe connections may differ, depending on the type of sample system you are using. Connect the moisture probe using a continuous run of GE Panametrics two-wire shielded cable (see Figure 2-3 below).

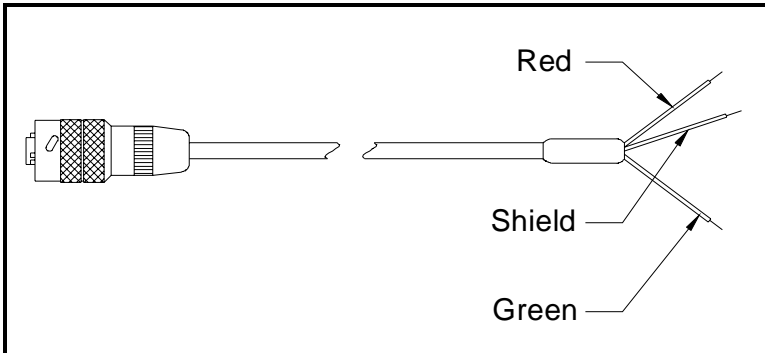

Figure 2-3: Two-Wire Shielded Cable

Protect all cables from excessive strain (bending, pulling, etc.). Do not subject cables to temperatures above +65°C (149°F) or below -50°C (-58°F). You can order standard cable assemblies (including connectors) from GE Panametrics in any length up to 100 meters (330 feet).

Use the following steps to make probe connections:

Note: *Probe connections for an internal sample system have been described in the previous section. The following instructions are for an external sample system only.*

1. Turn off the Series 35 IS.
2. Connect the cable to the probe by inserting the bayonet-type connector onto the probe and twisting the shell clockwise until it snaps into a locked position.

Making External Probe Connections (cont.)

Note: *The connector on the probe cable must be rotated until it aligns with the pins in the probe connector, before the cable may be properly inserted into the probe and secured.*

3. Connect the other end of the probe cable to the terminal block on the Series 35 IS side panel (see Table 2-1 below and Figure 2-4 on page 2-13).

IMPORTANT: *To maintain good contact at each terminal block and to avoid damaging the pins on the connector, pull the connector straight off (not at an angle), make cable connections while the connector is away from the unit, and push the connector straight on (not at an angle) when the wiring is complete.*

NOTICE FOR BASEEFA CERTIFICATION

The M Series probe may not be capable of withstanding the 500 V insulation test required by clause 5.7 of EN50 020 when installed in the process media. This must be taken into account in any installation in which it is used.
(See Cert. #Ex95C2002X in its entirety.)

Table 2-1: Probe Connections

Connect:	To PROBE Terminal Block
Red (H2) wire	pin 1
Shield	pin 2
Green (H1) wire	pin 3

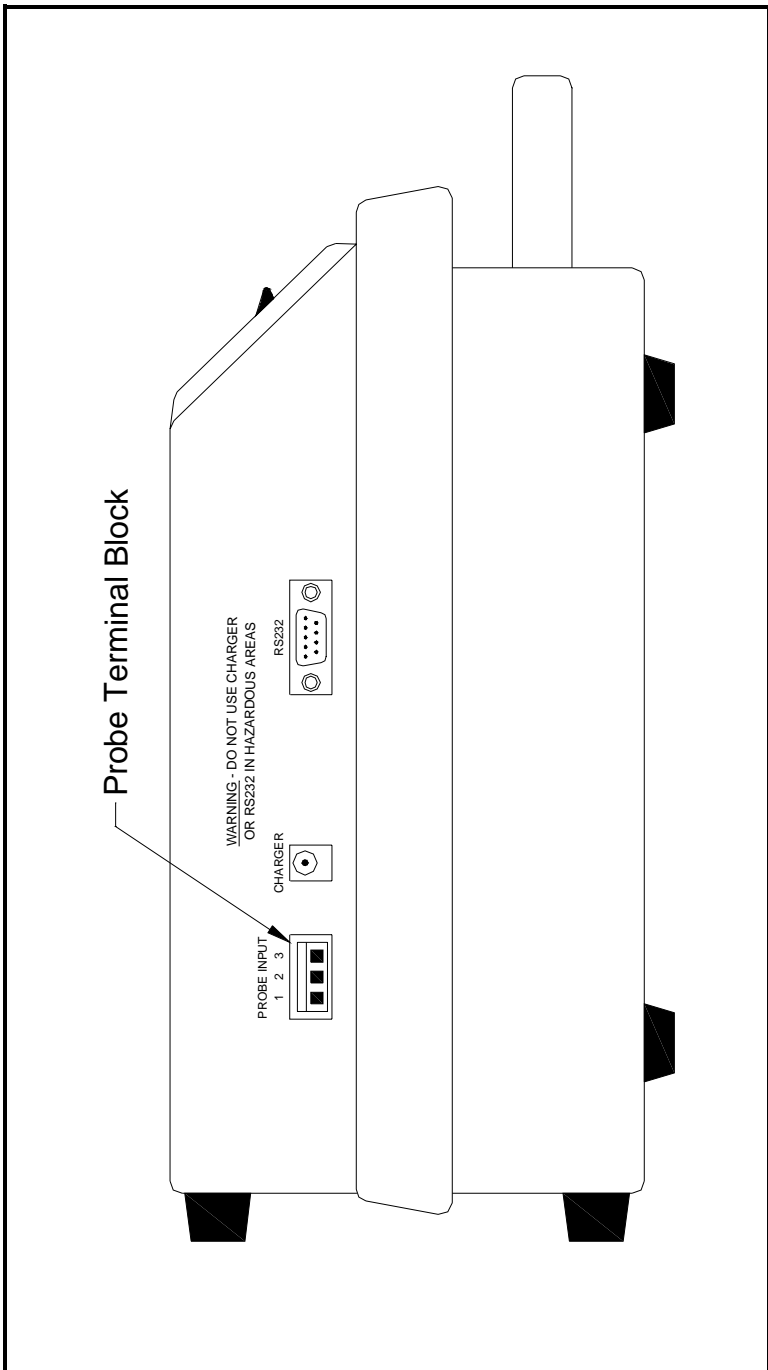

Figure 2-4: Probe Terminal Block Location

Using Modified or Non-GE Panametrics Cables

In some installations, it may be desirable to use a pre-existing moisture cable or to modify the standard GE Panametrics moisture cable. If this approach is taken, it is essential that the following precautions be observed. Furthermore, after connecting the moisture probe, a calibration adjustment must be performed to compensate for any electrical offsets introduced by the non-standard cable.

Caution!

GE Panametrics cannot guarantee operation of the Series 35 IS to the specified accuracy unless a standard GE Panametrics hygrometer cable is used.

1. Use cable that matches the electrical characteristics of GE Panametrics cable (contact the factory for specific information on cable characteristics).
2. If possible, avoid all splices. Splices will impair the performance of the instrument. When possible, instead of splicing, coil the excess cable.
3. If you must splice cables, be sure the splice introduces minimum resistive leakage or capacitive coupling between conductors.
4. Carry the shield through any splice. A common mistake is to not connect the shields over the splice. If you are modifying a GE Panametrics cable, the shield will not be accessible without cutting back the cable insulation. Also, do not ground the shield at both ends. The shield should be grounded only at the hygrometer end, as described in Table 2-1 on page 2-12.

Performing a Calibration Adjustment

After completing the installation of a modified or non-standard moisture cable, it is necessary to perform a calibration adjustment on the Series 35 IS. This procedure will adjust the electronics to compensate for any error or offset introduced by splices or long cable lengths. It is also recommended that a calibration be performed after the installation of a new GE Panametrics cable, to verify the accuracy of the unit.

Use the following steps to perform a calibration adjustment:

1. Power up the Series 35 IS.
2. To check the new cable, set up the screen to display “MH”. See Chapter 3, *Operating the Series 35 IS*, for instructions on how to navigate through the user program.
3. Note the high, low and zero reference values that are recorded on the sticker located on the inside of the Series 35 IS chassis.
4. Disconnect the cable from the probe only (leave the cable connected to the Series 35 IS), and verify that the displayed MH value equals the zero reference value within ± 0.0003 MH. If this reading is within specifications, no further testing is necessary.
5. If the zero reference value reading above was out of range, the low reference value must be adjusted. For readings more than 0.0003 below the previously recorded zero reference value, add the difference to the low reference value. For readings more than 0.0003 above the previously recorded zero reference value, subtract the difference from the low reference value. Record the final corrected low reference value.
6. Reprogram the Series 35 Is with the new, corrected low reference value. See *Entering High and Low Reference Values* in Chapter 3.
7. Make sure the cable is still disconnected from the probe but is connected to the Series 35 IS.

Performing a Calibration Adjustment (cont.)

8. Recheck the zero reference reading and verify that it is now within ± 0.0003 MH of the previously recorded value.
9. Fill out a new reference sticker with the final low reference value and/or record the information on the *Data Information Sheet* in Appendix D. Make sure the following information is included:
 - HIGH REF = Original Value
 - LOW REF = New Corrected Value
 - ZERO REF = Original Recorded Value

10. Reconnect the cable to the probe.

Note: *If the cable is changed in any way, repeat the above procedure for maximum accuracy of the unit.*

The Series 35 IS is now ready for operation. Proceed to Chapter 3, *Operating the Series 35 IS*.

Chapter 3

Operating the Series 35 IS

Your factory-programmed Series 35 IS can begin taking measurements as soon as you turn the power on. The user program enables you to enter and change setup information.

Note: *The Series 35 IS suspends taking measurements when you enter the user program listed below. Refer to the menu map in Appendix C to navigate the user program.*

This section explains the following procedures:

- Getting Started [page 3-2]
- Using the Keypad to Enter and Change Data [page 3-5]
- Verifying and Changing Factory Setup Data [page 3-9]
- Changing the Measurement Display [page 3-14]
- Entering an Offset Value for Dew/Frost Point [page 3-15]
- Entering a Constant Pressure Value [page 3-16]
- Entering a PPMv Constant Multiplier [page 3-18]
- Entering an Interval for Automatic Calibration [page 3-19]
- Viewing the Battery Status [page 3-21]
- Entering a Backlight-On Time Interval [page 3-22]
- Setting Up Computer-Enhanced Response [page 3-23]
- Setting Up Range Error Processing [page 3-25]
- Selecting AC Line Frequency (60/50 Hz) [page 3-26]
- Adjusting the Contrast [page 3-27]
- Setting the Clock Values [page 3-28]
- Setting Up the Data Logger [page 3-30]

Getting Started

Your unit is completely set up at the factory. To begin taking measurements, you only need to apply power to the unit and start up the sample system. Complete the instructions in the following sections to get your unit up and running:

- Starting Up and Shutting Down the Sample System
- Powering up the Series 35 IS

Starting Up and Shutting Down the Sample System

If your Series 35 IS has a self-contained sample system, use this section to properly *start up* the sample system before you begin taking measurements, and to *shut down* the sample system when you have finished taking measurements.

Note: *If you are using an external sample system, refer to the separate manual supplied with your order.*

Starting Up the Sample System

In order to operate the self-contained sample system correctly, first determine if you need to make measurements at atmospheric pressure or at process pressure. After determining the pressure, use the appropriate section that follows to start up and shut down the sample system.

Note: *The maximum allowable pressure for the self-contained sample system for the Series 35 IS is 4500 psig.*

At Atmospheric Pressure:

1. Begin with the Series 35 IS inlet and outlet valves in the closed position, then open the outlet valve completely.
2. Open the inlet valve slightly to allow only a small amount of flow from the process.

At Process Pressure:

1. Begin with the Series 35 IS inlet and outlet valves in the closed position, then slowly open the inlet valve fully.
2. Open the outlet valve slightly to allow only a small amount of flow.

Shutting Down the Sample System

At *Atmospheric or Process* Pressure:

1. Close the inlet valve completely.
2. Wait for the flow from the outlet valve to stop.
3. Close the outlet valve to keep the probe sensor from being affected by ambient moisture.

Powering Up the Series 35 IS

To turn on the Series 35 IS, press the POWER switch (located on the left side of the front panel) to the ON position. (If the battery is depleted, see Chapter 4, *Troubleshooting*, to recharge the battery.)

The Series 35 IS displays “Loading. . . .”, followed by a series of additional screens. This indicates that the system is loading calibration and reference data. After this data is loaded, the Series 35 IS automatically calibrates (Autocal) the moisture circuitry, and then begins taking measurements.

Using the Keypad to Enter and Change Data

The Series 35 IS user program enables you to change factory set-up data and user-defined program functions.

Use the appropriate sections that follow to learn how to:

- Use the programming keys
- Enter and exit the user program
- Move through the user program
- Enter numeric data

How to Use the Programming Keys

The membrane keypad to the right of the display window on the front panel of the Series 35 IS contains six (6) keys:

- **ENTER** - Use this key to: enter a menu option; switch from viewing to editing data; move to the next digit position during numeric entry; confirm an entry.
- **ESC** - Use this key to: cancel an entry; move back up one level in the menu sequence.
- **Δ** - This key scrolls upward through the menu options and increases the value during numeric entry.
- **∇** - This key scrolls downward through the menu options and decreases the value during numeric entry.
- **HYGRO** - Press this key in measurement mode to display the dew/frost point temperature in the selected units.
- **P_{const}** - Press this key in measurement mode to display the pressure in the selected units.

How to Enter and Exit the User Program

To enter programming mode, perform the following sequence within five (5) seconds, or the Series 35 IS will time out and return to measurement mode.

P: +0.00 Kcmg	While in measurement mode, press the [ESC] key.
----------------------------------	---

ESC	Within 5 seconds of the appearance of this display, press the [ENTER] key followed by the [ESC] key.
-----	--

PROGRAM MENU	This will display for 1 second.
--------------	---------------------------------

DP RANGE	You are now in the user program menu.
----------	---------------------------------------

From the main menu, use the arrow keys to scroll through the options to your selection. Use the [ENTER] key to confirm your selection or the [ESC] key to cancel your selection.

To exit the user program, press the [ESC] key until RUN ? displays, then press the [ENTER] key to return to displaying measurements.

DP RANGE	Press the [ESC] key.
----------	----------------------

RUN?	Press the [ENTER] key.
------	------------------------

Exiting.....	This will display for 1 second.
--------------	---------------------------------

P: +0.00 Kcmg	You have now returned to measurement mode.
----------------------------------	--

How to Move Through the User Program

Use the arrow keys to scroll through the following menu options. Refer to the Menu Map (Figure C-1) in Appendix C as a guide, while moving through the user program.

Note: *While in the programming mode, the Series 35 IS suspends taking measurements.*

- **DP RANGE** - Use to enter high and low dew points for the calibration curve. This input determines the number of points in the Moisture Probe Calibration Data entry, and shows the maximum/minimum dew point values in degrees celsius (°C), as shown on the Moisture Probe Calibration Data Sheet.
- **MH CURVE** - Use to enter a value for each point in the calibration curve. This Moisture Probe Calibration Data Entry accepts only MH values. The dew point automatically increases at 10°C intervals.
- **SERIAL #** - Input the moisture probe serial number.
- **HYGRO REFERENCE** - Use to enter high and low reference values for moisture measurement.
- **USER** - Use to set up user-defined program functions, such as offset value, constant pressure, PPMv multiplier, Autocal interval, battery, backlight interval, computer enhanced response (optional), range error handling, selecting 60/50 Hz, contrast, and clock.
- **FACTORY SETUP** - Used for GE Panametrics field service and factory use only. A passcode is required to access this function.
- **LOGGER** - This optional section lets you program the unit to log data at pre-selected time intervals and access the logged data for viewing or for sending to a dump terminal. It includes log interval, log setup, log display, and log dump settings.

How to Enter Numeric Data

To enter numbers one digit at a time, use the arrow keys to scroll to the desired number, then press the [ENTER] key to move to the next digit position. Repeat this procedure until all numbers have been entered.

Note: *In the programming mode, pressing an arrow key lets you enter the edit mode. Pressing [ESC] terminates the edit mode without changing any data. In edit mode, check all characters before pressing the [ENTER] key and moving to the next digit position.*

Verifying and Changing Factory Setup Data

Use this section to confirm, or make any necessary changes to, the factory setup data. The setup data includes information regarding the moisture probe as listed below:

- Dew point range
- Calibration data
- Probe serial number
- High and low reference values

Note: *Remember to record all setup data in Appendix D, Data Information Sheet, in the back of this manual.*

The factory enters all the necessary data into your Series 35 IS. Therefore, you should not need to re-enter this data unless you

- Purchase a new probe
- Recalibrate an existing probe
- Have reason to believe the data is corrupted.

Use the appropriate sections that follow to verify and/or change the setup data.

Entering the Dew Point Range

Use the DP RANGE to enter high and low dew point values. The Series 35 IS uses this range to determine the number of points in the calibration curve.

Note: *Enter the user program as described on page 3-6.*

DP RANGE

Use the arrow keys to scroll to DP RANGE and press the [ENTER] key.

Hi DP

Scroll to this screen with the arrow keys and press the [ENTER] key.

Hi DP +20°C

Use the arrow keys to scroll to the desired dew point value, then press the [ENTER] key.

Note: *The high and low dew points are listed on the Moisture Probe Calibration Data Sheet located in the probe box. The default values are: Low = -110°C, High = +20°C.*

Hi DP

Press the down arrow key.

Low DP

Press the [ENTER] key.

Low DP -110°C

Use the arrow keys to scroll to the desired value. Then, press the [ENTER] key.

Low DP

Press [ESC] to return to the main menu, and proceed to the next section.

IMPORTANT: *If you change the dew point settings, you must change the calibration curve also.*

Entering Calibration Data

After entering the high and low dew point values, use the MH CURVE option to enter calibration data for the moisture probe in accordance with the following procedure.

Note: *Remember to record all set-up data in Appendix D, Data Information Sheet, in the back of this manual.*

Moisture probe calibration data is taken at fixed dew point values in 10°C intervals. After the high and low dew point values have been entered, the appropriate number of data points for the moisture probe is automatically determined. Starting with the minimum dew point value, the MH values must be entered in 10°C increments until the maximum dew point is reached.

Note: *Changing the dew point setting affects the MH curve.*

MH CURVE

Use the arrow keys to scroll to MH CURVE and press the [ENTER] key.

-110°C MH 0.1890

Press the arrow keys to scroll through the MH values. Press [ENTER] then the arrow keys to edit a value. (ED displays in edit mode and MH displays in view mode.) Using the arrow keys and the [ENTER] key, edit the value one digit at a time, and then press [ENTER].

Note: *To abort the editing function at any time without changing the value, press the [ESC] key.*

Repeat the above procedure for each point in the MH Curve. Then, press [ESC] until you return to main menu and proceed to the next section.

Entering the Probe Serial Number

The probe serial number is listed on the Calibration Data Sheet and is inscribed on the hex nut of the moisture probe.

Note: *Remember to record all set up data in Appendix D, Data Information Sheet, in the back of this manual.*

USER

From the main menu, use the arrow keys to scroll to the USER prompt, then press the [ENTER] key to view the options.

SERIAL #

Use the arrow keys to scroll to SERIAL # and press the [ENTER] key.

xxxxxx S/N

The unit displays the current serial number.

123456 S/N

To edit the serial number, press an arrow key and a blinking cursor appears at the left-most digit. Use the arrow keys to scroll to the desired value and press [ENTER] to move the cursor to the next digit. Repeat until you have entered all six serial number digits. Press the [ENTER] key to confirm the change or the [ESC] key to cancel the change.

SERIAL #

Press the [ESC] key to return to the main menu.

To enter more setup data, proceed to the appropriate section of this manual. To return to measurement mode, press [ESC] until the RUN ? prompt appears and then press the [ENTER] key.

Entering High and Low Reference Values

The Series 35 IS requires high and low reference values for its moisture measurement circuitry. These factory calibration values, specific to each unit, are listed on a label inside the unit.

IMPORTANT: *Do not change the high and/or low reference values unless instructed to do so by GE Panametrics.*

Note: *Remember to record all setup data in Appendix D, Data Information Sheet, in the back of this manual.*

HYGRO REFERENCE

Use the arrow keys to scroll to HYGRO REFERENCE and press the [ENTER] key.

High REF

Press either arrow key to scroll to the High REF option, then press the [ENTER] key.

HX.XXXX

Use the arrow and [ENTER] keys to change the value one digit at a time, then press [ENTER].

Note: *To abort the editing function at any time without changing the value, press the [ESC] key.*

Low REF

Press either arrow key to scroll to the Low REF option, then press the [ENTER] key.

LX.XXXX

Use the arrow and [ENTER] keys to change the value one digit at a time, then press [ENTER].

To enter more setup data, proceed to the appropriate section of this manual. To return to measurement mode, press [ESC] until the RUN ? prompt appears and then press the [ENTER] key.

Changing the Measurement Display

The front panel of the Series 35 IS contains two keys that let you quickly change the L.C.D. display mode during operation of the unit. These display keys are labeled HYGRO and P_{const}.

- **HYGRO** - Press this key to display and scroll through all the available moisture measurement units (DP/°C, DP/°F, PMv, MH).
- **P_{const}** - Press this key to display and scroll through all available constant pressure units (PSG, Bar, KPAG, Kcmg).

After you select a specific display mode, that display remains on the screen until you choose another display mode or until you enter the programming mode. Upon exiting the programming mode and returning to measurement mode, the screen automatically returns to the previously selected display mode.

Entering an Offset Value for Dew/Frost Point

Use this option to adjust the displayed dew/frost point reading. A positive number increases the reading and a negative number decreases the reading. The offset value always displays in dew/frost point degrees C.

Note: Enter the user program as described on page 3-6.

USER

From the main menu, use the arrow keys to scroll to the USER prompt, then press the [ENTER] key to view the options.

OFFSET

Use the arrow keys to scroll to OFFSET and press the [ENTER] key.

OFFSET +5.0 °C

The current offset value is displayed.

OFFSET +10.0 °C

Press either arrow key to delete the current value and enter the edit mode. Use the arrow and [ENTER] keys to change the value one digit at a time, then press the [ENTER] key.

Note: To abort the editing function at any time without changing the value, press the [ESC] key.

OFFSET

Press the [ESC] key to return to the main menu.

To enter more setup data, proceed to the appropriate section of this manual. To return to measurement mode, press [ESC] until the RUN ? prompt appears and then press the [ENTER] key.

Entering a Constant Pressure Value

This option lets you enter a fixed value for the pressure of the sample gas at the moisture probe location. The value is used to calculate the moisture content in PPM_v.

Note: Enter the user program as described on page 3-6.

USER	From the main menu, use the arrow keys to scroll to the USER prompt, then press the [ENTER] key to view the options.
------	--

CONSTANT PRESSUR	Use the arrow keys to scroll to CONSTANT PRESSUR and press the [ENTER] key.
------------------	---

KP PSlg	The current units choice is displayed. Use the arrow keys to scroll to the desired pressure units, then press the [ENTER] key. See Table 3-1 below for the available choices.
---------	---

Table 3-1: Constant Pressure Units

Available Units	Description of Units
KP psig	pounds per square inch gauge
KP bar	bars absolute
KP KPag	kilopascals gauge
KP Kcmg	kilograms per square centimeter gauge

KP: +XXX.XX PSG	The current constant pressure value is displayed.
---------------------------	---

Note: To abort the editing function at any time without changing the value, press the [ESC] key.

Entering a Constant Pressure Value (cont.)

KP: +500.00 PSG

Press either arrow key to delete the current value and enter edit mode. Use the arrow and [ENTER] keys to change the value one digit at a time, then press [ENTER].

KP: +XXX.XX PSG

The new constant pressure value is displayed. Press [ESC].

KP PSlg

The current units choice is displayed. Press [ESC] to return to the options menu.

CONSTANT PRESSUR

Press the [ESC] key to return to the main menu.

To enter more setup data, proceed to the appropriate section of this manual. To return to measurement mode, press [ESC] until the RUN ? prompt appears and then press the [ENTER] key.

Entering a PPMv Constant Multiplier

Use this option to apply a user-defined constant multiplier to the PPMv value.

Note: *Enter the user program as described on page 3-6.*

USER

From the main menu, use the arrow keys to scroll to the USER prompt, then press the [ENTER] key to view the options.

PPMv MULTIPLIER

Use the arrow keys to scroll to PPMv MULTIPLIER and press the [ENTER] key.

KPPMv 1.0000

The current value is displayed. Press either arrow key to delete the current value and enter the edit mode.

KPPMv X.XXXX

Use the arrow and [ENTER] keys to enter the new multiplier, one digit at a time. Then, press [ENTER] twice to return to the options menu.

PPMv MULTIPLIER

Press the [ESC] key to return to the main menu.

Note: *PPMv constant multiplier values up to 999.9999 may be entered, but the value should be set at 1.0000 unless otherwise advised by GE Panametrics. Be sure to record all entered data in Appendix D, Data Information Sheet, in the back of this manual.*

To enter more setup data, proceed to the appropriate section of this manual. To return to measurement mode, press [ESC] until the RUN ? prompt appears and then press the [ENTER] key.

Entering an Interval for Automatic Calibration

The Series 35 IS automatically calibrates itself (Autocal) at user-programmable time intervals, in order to compensate for any drift in the electronics. An Autocal interval value between 0 and 1440 minutes (24 hours) may be entered. GE Panametrics recommends setting the Autocal interval to eight hours (480 minutes). If the Series 35 IS is exposed to extreme temperatures or weather conditions, a shorter Autocal interval may be more appropriate.

Note: *Enter the user program as described on page 3-6.*

USER

From the main menu, use the arrow keys to scroll to the USER prompt, then press the [ENTER] key to view the options.

AUTOCAL INTERVAL

Use the arrow keys to scroll to AUTOCAL INTERVAL and press the [ENTER] key.

ACAL (Mins) 30

The current Autocal interval value is displayed.

ACAL (Mins) XX

Press either arrow key to delete the current value and enter the edit mode. Use the arrow and [ENTER] keys to change the value one digit at a time, then press [ENTER] to return to the options menu.

AUTOCAL INTERVAL

Press the [ESC] key to return to the main menu.

To enter more setup data, proceed to the appropriate section of this manual. To return to measurement mode, press [ESC] until the RUN ? prompt appears and then press the [ENTER] key.

Entering an Interval for Automatic Calibration (cont.)

After you confirm the Autocal interval and return to the main menu, the Series 35 IS immediately performs an Autocal. The next time Autocal occurs depends on the length of the time interval setting.

The Series 35 IS determines the times of subsequent Autocal by establishing a fixed schedule, beginning at midnight, using the specified interval. For example, if you enter a 90-minute time interval, Autocal occurs 16 times per day

$$(1 \text{ day} = 1440 \text{ minutes} \div 90 \text{ minutes} = 16).$$

The following fixed schedule applies:

- | | |
|----------------------------|---------------------------------|
| 1. 1:30 a.m. | 9. 1:30 p.m. |
| 2. 3:00 a.m. | 10. 3:00 p.m. |
| 3. 4:30 a.m. | 11. 4:30 p.m. |
| 4. 6:00 a.m. | 12. 6:00 p.m. |
| 5. 7:30 a.m. | 13. 7:30 p.m. |
| 6. 9:00 a.m. | 14. 9:00 p.m. |
| 7. 10:30 a.m. | 15. 10:30 p.m. |
| 8. 12:00 p.m.(noon) | 16. 12:00 a.m.(midnight) |

If you enter a time interval not evenly divisible into 1440 minutes, the Series 35 IS rounds up to the next acceptable interval. For example, if you set the 90-minute Autocal interval at 6:10 p.m., the next Autocal occurs at 7:30 p.m. (excluding the Autocal performed when you exit the Autocal menu).

Viewing the Battery Status

Make sure that the battery charger is disconnected before viewing the battery status.

Note: *Enter the user program as described on page 3-6.*

USER

From the main menu, use the arrow keys to scroll to the USER prompt, then press the [ENTER] key to view the options.

BATTERY

Use the arrow keys to scroll to the BATTERY option and press the [ENTER] key.

DISCONNECT A.C.

Press ENTER

The display alternates between the two messages shown. Press the [ENTER] key when the AC power has been disconnected.

BAT: +6.89 V

BAT: 100%

The display alternates between the two messages shown. Press the [ESC] key to return to the options menu.

BATTERY

Press the [ESC] key to return to the main menu.

To enter more setup data, proceed to the appropriate section of this manual. To return to measurement mode, press [ESC] until the RUN ? prompt appears and then press the [ENTER] key.

Entering a Backlight-On Time Interval

Your Series 35 IS is equipped with a backlight, which can be programmed to turn off automatically after a pre-determined time. Values between 0 and 1440 minutes (24 hours) may be entered.

Note: *Enter the user program as described on page 3-6.*

USER	From the main menu, use the arrow keys to scroll to the USER prompt, then press the [ENTER] key to view the options.
BACKLIGHT	Use the arrow keys to scroll to BACKLIGHT and press the [ENTER] key.
BLITE (Mins) 30	The current backlight interval value is displayed.
BLITE (Mins) XX	Press either arrow key to delete the current value and enter the edit mode. Use the arrow and [ENTER] keys to change the value one digit at a time, then press [ENTER] to return to the options menu.
BACKLIGHT	Press the [ESC] key to return to the main menu.

Note: *Constant use of the backlight shortens the battery life. All units are shipped with a default backlight-on time interval of 5 minutes.*

To enter more setup data, proceed to the appropriate section of this manual. To return to measurement mode, press [ESC] until the RUN ? prompt appears and then press the [ENTER] key.

Setting Up Computer-Enhanced Response

Note: *This option may not be installed on your Series 35 IS.*

Using a dynamic moisture calibration technique, Computer-Enhanced Response extrapolates the moisture level to the end point, when making measurements in abrupt “dry down” conditions. Response time depends on the relative change in dew point. For example, the Series 35 IS can respond in three to five minutes to reflect a change from ambient moisture to trace levels.

The accuracy of Computer-Enhanced Response equals $\pm 2^{\circ}\text{C}$ of the sensor reading, assuming an equilibrium with the gas. To ensure accuracy, your application should:

- Have a reasonably constant flow rate and final dew point.
- Maintain a minimum flow rate of one standard cubic foot per hour (SCFH).
- Operate at atmospheric pressure (0 psig)
- The actual moisture content must be above -85°C frost point and must be stable.

You can enable or disable the Computer-Enhanced Response feature. If the feature is not available, the display reads Option Not Avail. Otherwise, the Enhance Response display appears.

Note: *Enter the user program as described on page 3-6.*

USER

From the main menu, use the arrow keys to scroll to the USER prompt, then press the [ENTER] key to view the options.

ENHANCE RESPONSE

Use the arrow keys to scroll to the ENHANCE RESPONSE option and press the [ENTER] key.

Setting Up Computer-Enhanced Response (cont.)

ENHANCE OFF

Use the arrow keys to scroll to one of the option screens shown and press the [ENTER] key.

ENHANCE ON

ENHANCE RESPONSE

Press the [ESC] key to return to the main menu.

Note: *An activated Computer Enhanced Response displays a reverse video “E” on the left side of the display. After determining the final value, the reverse video “E” changes to a regular “E”.*

To enter more setup data, proceed to the appropriate section of this manual. To return to measurement mode, press [ESC] until the RUN ? prompt appears and then press the [ENTER] key.

Setting Up Range Error Processing

Range errors occur when an input signal within the capacity of the analyzer is outside the range of the probe calibration data. The Series 35 IS displays Range Errors with an OVER RANGE or UNDER RANGE message. The error condition extends to all displayed measurements of that mode. For example, if dew point displays OVER RANGE, then moisture in PPMv also displays OVER RANGE.

There are two available Range Error processing options:

- No Action - the range error is not displayed.
- Display - the range error is displayed.

Note: Enter the user program as described on page 3-6.

USER

From the main menu, use the arrow keys to scroll to the USER prompt, then press the [ENTER] key to view the options.

RANGE ERROR

Use the arrow keys to scroll to the RANGE ERROR option and press the [ENTER] key.

R_ERR = Display

Use the arrow keys to scroll to one of the options shown and press the [ENTER] key.

R_ERR = No Action

RANGE ERROR

Press the [ESC] key to return to the main menu.

To enter more setup data, proceed to the appropriate section of this manual. To return to measurement mode, press [ESC] until the RUN ? prompt appears and then press the [ENTER] key.

Selecting AC Line Frequency (60/50 Hz)

Select this setting according to the AC line frequency in the country where the Series 35 IS is installed.

Note: *Enter the user program as described on page 3-6.*

USER

From the main menu, use the arrow keys to scroll to the USER prompt, then press the [ENTER] key to view the options.

SELECT 60/50 HZ

Use the arrow keys to scroll to the SELECT 60/50 HZ option and press the [ENTER] key.

60HZ

Use the arrow keys to scroll to one of the options shown and press the [ENTER] key.

50HZ

SELECT 60/50 HZ

Press the [ESC] key to return to the main menu.

Note: *For reference, record all entered data in Appendix D, Data Information Sheet, in the back of this manual.*

To enter more setup data, proceed to the appropriate section of this manual. To return to measurement mode, press [ESC] until the RUN ? prompt appears and then press the [ENTER] key.

Adjusting the Contrast

Use this option to adapt to the lighting conditions of the Series 35 IS installation.

Note: *Enter the user program as described on page 3-6.*

USER

From the main menu, use the arrow keys to scroll to the USER prompt, then press the [ENTER] key to view the options.

CONTRAST

Use the arrow keys to scroll to the CONTRAST option and press the [ENTER] key.

Adj. Contrast

Press the up-arrow key to increase contrast or the down-arrow key to decrease, contrast. Hold the key down for large changes or press repeatedly for small changes. Press the [ENTER] key to confirm the new setting.

CONTRAST

Press the [ESC] key to return to the main menu.

To enter more setup data, proceed to the appropriate section of this manual. To return to measurement mode, press [ESC] until the RUN ? prompt appears and then press the [ENTER] key.

Setting the Clock Values

The Series 35 IS has no backup power source, and the time/date must be reset whenever the battery has been totally depleted.

Note: *Enter the user program as described on page 3-6.*

USER

From the main menu, use the arrow keys to scroll to the USER prompt, then press the [ENTER] key to view the options.

CLOCK

Use the arrow keys to scroll to the CLOCK option and press the [ENTER] key.

Read Time

Use the arrow keys to scroll to READ TIME then press the [ENTER] key.

hh:mm mm/dd/yy

The current time and date are displayed for 2 seconds, before the CLOCK prompt returns.

To edit the time, use the following steps:

CLOCK

Press the [ENTER] key.

Set Time

Use the arrow keys to scroll to SET TIME. Then, press the [ENTER] key.

hh:mm

Use the arrow and [ENTER] keys to scroll to the correct hour and minutes values. Then, press the [ENTER] key.

Set Time

Press [ESC] to return to the CLOCK prompt.

Setting the Clock Values (cont.)

To edit the date, use the following steps:

CLOCK

Press the [ENTER] key.

Set Date

Use the arrow keys to scroll to SET DATE. Then, press the [ENTER] key.

MM/DD/YY

Use the arrow and [ENTER] keys to scroll to the correct month, day and year values. Then, press the [ENTER] key.

Note: *The Series 35 IS clock is year 2000 compliant.*

Set Date

Press [ESC] to return to the CLOCK prompt.

CLOCK

Press the [ESC] key to return to the main menu.

To enter more setup data, proceed to the appropriate section of this manual. To return to measurement mode, press [ESC] until the RUN ? prompt appears and then press the [ENTER] key.

Setting Up the Data Logger

The Series 35 IS optional data logging feature enables you to internally view and store measurement data. The main menu displays the **LOGGER** prompt only if this option is available on your unit.

Data is logged at user-selected time intervals and stored in the unit's FRAM. Up to three different parameters may be logged at any one time.

Note: *Because the Series 35 IS contains a fixed amount of memory, the more parameters you select and the more frequently you log data, the shorter the total available logging time.*

The Series 35 IS assigns a *record* and a *header* to all logged data. The *record* consists of logged measurement values. The *header* includes the time the log started, the constant pressure value, the log time intervals, and the selected measurement modes. By assigning each log a header, the Series 35 IS distinguishes one log from another.

The Series 35 IS can store more than one log. Each time the log setting is changed, the Series 35 IS queries if you want to overwrite or append to the existing log(s). If overwrite mode is chosen, the Series 35 IS writes over the logs currently stored in memory. If append mode is chosen, the Series 35 IS adds new log data to the end of the previously stored log data. In either case, the Series 35 IS continues logging measurement data until it runs out of memory.

Note: *Before beginning setup of the data logger, check to make sure that the clock is set to the correct time and date. See "Setting the Clock Values" on page 3-28 for the procedure to follow.*

Setting the Data Logger Time Interval

The Series 35 IS logs measurement data at a time interval that is specified by the user.

Note: *Enter the user program as described on page 3-6.*

LOGGER

From the main menu, use the arrow keys to scroll to the LOGGER prompt, then press the [ENTER] key.

LOG INTERVAL

Use the arrow keys to scroll to the LOG INTERVAL option and press the [ENTER] key.

LINTV (Mins)	15
--------------	----

The current log interval is displayed. Press either arrow key to delete the current value and enter the edit mode.

LINTV (Mins)	XX
--------------	----

Use the arrow and [ENTER] keys to change the value one digit at a time, then press [ENTER] to confirm the new value.

LINTV (Mins)	30
--------------	----

The new log interval is displayed. Press [ENTER] to return to the options menu.

LOG INTERVAL

Press the [ESC] key to return to the main menu.

Note: *Data logging is suspended when you enter the programming mode. If you remain in the programming mode longer than the log intervals, the System 35 IS appends a new log when you exit in order to track the log time properly. Also, a new log is appended to the current log on power up.*

Entering the Parameter(s) to Log

Use this option to enter the parameters to be logged. You may log up to three different parameters at the same time.

Note: *Enter the user program as described on page 3-6.*

LOGGER

From the main menu, use the arrow keys to scroll to the **LOGGER** prompt, then press the [ENTER] key.

LOG SETUP

Use the arrow keys to scroll to the **LOG SETUP** option and press the [ENTER] key.

Note: *Before beginning setup of the data logger, check to make sure that the clock is set to the correct time and date. See “Setting the Clock Values” on page 3-28 for the procedure to follow.*

L/MODE# X

Select the desired parameter number (1, 2, or 3) with the arrow keys and then press the [ENTER] key.

LM=HYG

Use the arrow keys to select the desired mode (HYG, NONE, or BAT). Press the [ENTER] key.

LM=HYG DP/°C

Use the arrow keys to select the desired units setting (MH, PMv, DP/°F, DP/°C, or DVM). Then, press the [ENTER] key.

Note: *If the NONE or BAT mode is chosen, the units setting screen will not appear. Simply press [ENTER] to return to the parameter number screen.*

Entering the Parameter(s) to Log (cont.)

L/MODE# X

If desired, repeat the above procedure to set up the other two parameters. When finished, press the [ESC] key.

Note: *Because the Series 35 IS contains a fixed amount of memory, the more parameters you select and the more frequently you log data, the shorter the total available logging time.*

LOG SETUP

Press the [ESC] key to return to the main menu.

To enter more setup data, proceed to the appropriate section of this manual. To return to measurement mode, press [ESC] until the RUN ? prompt appears and then press the [ENTER] key.

Viewing Log Status, Summary and Data

Use this option to view the log status, log summary and log data. Be aware that the nature of the 16-character L.C.D. display will limit the ability to view the log data.

Note: *Enter the user program as described on page 3-6.*

LOGGER

From the main menu, use the arrow keys to scroll to the LOGGER prompt, then press the [ENTER] key.

LOG DISPLAY

Use the arrow keys to scroll to the LOG DISPLAY option and press the [ENTER] key.

Viewing Log Status

Note: *The log status applies only to the current log.*

VIEW LOG STATUS

Use the arrow keys to scroll to VIEW LOG STATUS and press the [ENTER] key.

Records: 109

Rem: 10h 10m

The number of data points logged and the remaining logging time screens will be displayed for about 2 seconds each.

VIEW LOG STATUS

Press the [ESC] key to return to the options menu.

To enter more setup data, proceed to the appropriate section of this manual. To return to measurement mode, press [ESC] until the RUN ? prompt appears and then press the [ENTER] key.

Viewing the Log Summary

Follow these instructions to view the log summary.

VIEW LOG SUMMARY	Use the arrow keys to scroll to VIEW LOG SUMMARY and press the [ENTER] key.
Total #Log: xx	The total number of logs in memory will be displayed for about 2 seconds.
LOG# x	For each log, the five screens shown will be displayed for about 2 seconds each.
Log Started at:	
hh:mm mm/dd/yy	
P: +x.xx PSG	
LINTV (Mins) x	

Note: *The Series 35 IS does not log time against each data point, but logs the log time interval at the start of a log. Use the log start time and log interval to determine the data log time.*

The above sequence of five screens will repeat automatically until all of the log summaries have been displayed.

Note: *The summary display may be terminated at any time by pressing the [ESC] key between any pair of the five-screen sequences. This will immediately return you to the options menu.*

Viewing the Log Summary (cont.)

VIEW LOG #: xx

After the log summary has been completed, the display shown will appear. Press the [ESC] key or proceed to the next section for instructions.

VIEW LOG SUMMARY

Press [ESC] to return to the options menu.

To enter more setup data, proceed to the appropriate section of this manual. To return to measurement mode, press [ESC] until the RUN ? prompt appears and then press the [ENTER] key.

Viewing Log Data

Follow these instructions to view the log data.

VIEW LOG DATA

Use the arrow keys to scroll to VIEW LOG DATA and press the [ENTER] key.

VIEW LOG #:	xx
-------------	----

After the log summary has been completed, the display shown will appear. Press the [ESC] key or proceed to the next section for instructions

Log Started at:

For the chosen log, the four screens shown will be displayed for about 2 seconds each.

hh:mm	mm/dd/yy
-------	----------

P:	+x.xx PSG
----	-----------

LINTV (Mins)	x
--------------	---

#x	+x.xx PMV
----	-----------

The list of items in the log may now be viewed. Use the arrow keys to scroll through the list.

Note: *If more than one parameter is being logged, use the [HYGRO] and [P_{const}] keys to scroll through the parameters for each item number.*

Table 3-2 on page 3-38 shows an example of a log containing three items and three parameters per item. Scroll through the table as follows:

- [↑]: scroll up a column of items
- [↓]: scroll down a column of items
- [HYGRO]: scroll right across a row of parameters
- [P_{const}]: scroll left across a row of parameters

Viewing Log Data (cont.)

Table 3-2: Log Layout Example

Item #	Parameter		
	PMV	DP/°F	MH
1	#1 0.00PMV	#1 -166.0DP/°F	#1 -0.0019MH
2	#2 0.00PMV	#2 -166.0DP/°F	#2 -0.0019MH
3	#3 0.00PMV	#3 -166.0DP/°F	#3 -0.0019MH

Note: *You can press [ESC] to stop viewing the log and return to the VIEW LOG DATA menu at any time.*

If you scroll all the way to either side of the table, you will not be able to scroll any further in that direction. However, you may scroll back in the opposite direction. Vertical scrolling to either the top or bottom edge of the table, respectively, will lead to one of the following screens:

Skip to next ?

Press [ENTER] to view the next or previous log. Press [ESC] to stop viewing the log data.

Skip to prev ?

<END>

Press [ESC] to exit.

VIEW LOG DATA

Press [ESC] to return to the options menu.

To enter more setup data, proceed to the appropriate section of this manual. To return to measurement mode, press [ESC] until the RUN ? prompt appears and then press the [ENTER] key.

Using the Built-In RS232 Interface

The Series 35 IS data log can be transferred to a dump terminal via the built-in RS232 interface. Use the following interface settings for the transfer:

- 8 data bits
- 1 stop bit
- no parity
- 9600 baud

IMPORTANT: *The RS232 interface setup and data transfer must be done in a non-hazardous area.*

One of the GE Panametrics RS232 cables listed in Table 3-3 below must be used to connect the RS232 connector on the Series 35IS to the serial port of the computer.

Table 3-3: RS232 Cable Assemblies

Part Number	# Pins on PC End	Length (ft)
704-693-02	9	5
704-693-03	9	10
704-693-04	9	15
704-693-05	9	20
704-693-12	25	5
704-693-13	25	10
704-693-14	25	15
704-693-15	25	20

IMPORTANT: *The end of the above cables with the “MMS 35 IS” label must be connected to the hygrometer and not to the PC. Also, standard RS232 cables will not work with the Series 35 IS. Refer to Figure B-4 in Appendix B for details of the RS232 cable construction.*

Dumping Logged Data Via the RS232 Interface

Use the following procedure to transfer logged data to a dump terminal via the built-in RS232 interface.

IMPORTANT: *Refer to “Using the Built-In RS232 Interface” on page 3-39 to make sure the Series 35 IS is set up properly for the transfer.*

LOGGER

In the main menu, use the arrow keys to scroll to **LOGGER** and press the [ENTER] key.

LOG DUMP

Use the arrow keys to scroll to **LOG DUMP** and press the [ENTER] key.

LOG DUMP ON

Use the arrow keys to scroll to **LOG DUMP ON** and press the [ENTER] key.

Dumping Log

Dump Completed

The entire log memory is transferred to the PC. The screens shown will display the status of the data dump.

Note: *The log dump may be terminated at any time by pressing the [ESC] key.*

LOG DUMP

Press the [ESC] key to return to the main menu.

Dumping Logged Data Via the RS232 Interface (cont.)

The format of the dump consists of a header, modes with the TAB delineator between titles, and data with the TAB delimiter between values. The information contained in a typical dump screen is shown in Figure 3-1 on page 3-42.

To enter more setup data, proceed to the appropriate section of this manual. To return to measurement mode, press [ESC] until the RUN ? prompt appears and then press the [ENTER] key.

Log Started at: 01/09/1999 10:13			
Constant Pressure = +0.00 PSG			
Logging Interval = 1 minutes			
LOG#=1			
Mode being Logged			
Time	H:DP/C	H:DP/F	H:PMv
10:13	-110	-166	0
10:14	-110	-166	0
10:15	-110	-166	0
10:16	-110	-166	0
10:17	-110	-166	0
10:18	-110	-166	0
10:19	-110	-166	0
10:20	-110	-166	0
10:21	-110	-166	0
Log Started at: 01/09/1999 10:26			
Constant Pressure = +0.00 PSG			
Logging Interval = 1 minutes			
LOG#=2			
Mode being Logged			
Time	H:DP/C	H:DP/F	H:PMv
10:26	-110	-166	0
Log Started at: 01/09/1999 10:29			
Constant Pressure = +0.00 PSG			
Logging Interval = 1 minutes			
LOG#=3			
Mode being Logged			
Time	H:DP/C	H:DP/F	H:PMv
10:29	-110	-166	0
10:30	-110	-166	0
Log Started at: 01/09/1999 10:31			
Constant Pressure = +0.00 PSG			
Logging Interval = 1 minutes			
LOG#=4			
Mode being Logged			
Time	H:PMv	H:DP/F	H:MH
10:31	0	-166	-0.0019
10:32	0	-166	-0.0019
10:33	0	-166	-0.0019
10:34	0	-166	-0.0019
10:35	0	-166	-0.0019
Dump Completed			

Figure 3-1: Example of a Dump Screen

Chapter 4

Troubleshooting and Maintenance

The Moisture Monitor Series 35 IS is designed to be maintenance and trouble free. Due to process conditions and other factors, however, minor problems may occur. This chapter discusses some of the most commonly encountered problems and the procedures for correcting them. If you cannot find the information you need in this chapter, contact GE Panametrics.

Caution!

Do not attempt to troubleshoot the Series 35 IS beyond the instructions in this chapter. If you do, you may damage the unit and void the warranty.

This section includes the following information:

- Common Problems [page 4-1]
- Screen Messages [page 4-5]
- Calibration Error Processing [page 4-7]
- Recharging and Replacing the Battery [page 4-8]
- Replacing the User Program [page 4-13]
- Replacing and Recalibrating the Moisture Probe [page 4-20]

Common Problems

Incorrect Series 35 IS measurement readings may indicate a problem with the probe or a component of the system. Table 4-1 on page 4-2 lists the most common problems that affect measurement and ways that you can rectify the problems.

Table 4-1: Troubleshooting Guide

Symptom	Possible Cause	System Response	Action
Accuracy of moisture sensor is questioned	Insufficient time for system to equilibrate	Probe reads too wet during dry down conditions, or too dry in wet up conditions	Change the flow rate. A change in dew point indicates the sample system is not at equilibrium, or there is a leak. Allow sufficient time for sample system to equilibrate and moisture reading to become steady. Check for leaks.
	Dew point at sampling point is different than the dew point of the main stream	Probe reads too wet or too dry	Readings may be correct if the sampling point and main stream do not run under the same process conditions. The different process conditions cause the readings to vary. Refer to Appendix A for more information. If sampling point and main stream conditions are the same, check sample system pipes and any pipe between the sample system and main stream for leaks. Also, check sample system for adsorbing water surfaces, such as rubber or plastic tubing, paper-type filters, or condensed water traps. Remove or replace contaminating parts with stainless steel parts.
	Sensor or sensor shield affected by process contaminant (refer to Appendix A)	Probe reads too wet or too dry	Clean the sensor and the sensor shield as described in Appendix A. Then reinstall the sensor.
	Sensor is contaminated with conductive particles (refer to Appendix A)	Probe reads high dew point	Clean the sensor and the sensor shield as described in Appendix A. Then reinstall the sensor. Also, install a proper filter (i.e. sintered or coalescing element).
	Sensor is corroded (refer to Appendix A)	Probe reads too wet or too dry	Return the probe to factory for evaluation.

Table 4-1: Troubleshooting Guide (cont.)

Symptom	Possible Cause	System Response	Action
Accuracy of moisture sensor is questioned	Sensor temperature is greater than 70°C (158°F)	Probe reads too dry	Return the probe to factory for evaluation.
	Stream particles causing abrasion	Probe reads too wet or too dry	Return the probe to factory for evaluation.
Slow response	Slow outgassing of system	N.A.	Replace the system components with stainless steel or electro-polished stainless steel
	Sensor is contaminated with non-conductive particles (refer to Appx. A)	N.A.	Clean the sensor and the sensor shield as described in Appendix A. Then, reinstall the sensor.
Accuracy of moisture sensor is questioned	Insufficient time for system to equilibrate	Probe reads too wet during dry down conditions, or too dry in wet up conditions	Change the flow rate. A change in dew point indicates the sample system is not at equilibrium, or there is a leak. Allow sufficient time for sample system to equilibrate and moisture reading to become steady. Check for leaks.
	Shorted circuit on sensor	N.A.	Run "dry gas" over sensor surface. If high reading persists, then probe is probably shorted and should be returned to the factory for evaluation.
	Sensor is contaminated with conductive particles (refer to Appendix A)	N.A.	Clean the sensor and the sensor shield as described in Appendix A. Then, reinstall the sensor.
	Improper cable connection	N.A.	Check the cable connections to both the probe and the Series 35 IS.

Table 4-1: Troubleshooting Guide (cont.)

Symptom	Possible Cause	System Response	Action
Screen always reads the driest (lowest) programmed moisture calibration value while displaying dew/frost point	Open circuit on sensor	N.A.	Return the probe to the factory for evaluation.
	Non-conductive material is trapped under contact arm of sensor	N.A.	Clean the sensor and the sensor shield as described in Appendix A. Then reinstall the sensor. If the low reading persists, return the probe to the factory for evaluation.
	Improper cable connection	N.A.	Check the cable connections to both the probe and the Series 35 IS.

Screen Messages

Several Series 35 IS screen messages may display during operation of the unit. Table 4-2 lists these messages, possible causes of them and recommended solutions to them.

Table 4-2: Screen Messages

Display	Possible Cause	System Response	Action
Blank	Loss of Power	System shutdown	Turn off unit and recharge or replace the battery. (See <i>Recharging and Replacing the Battery</i> , page 4-8.)
“Loading...” (reinitializes) “Autocal...” (displays measurement)	Watchdog reset	System resets because watchdog signal is not generated within 1.6 seconds. Fault alarm is on for approximately 20 seconds.	Call GE Panametrics if this happens more than 5 times within ten minutes.
“CAL ERROR”	Internal reference components may be out of specifications. (Only occurs when unit is set to measure DP/°C, DP/°F, or PPM _v .)	Measurement stops for affected modes.	Check wiring. Call GE Panametrics.
Reads over or under range	Signal received is lower or higher than calibration data supplied with probe	System defaults to lowest or highest dew point found in calibration data	Check probe for open circuit or shorts if probe is not subjected to extreme dry or wet conditions. Contact GE Panametrics regarding a higher calibrated probe.
“Supply Low” displays for 1 hour, then “Shutdown Please”	Battery power is low	Loss of power	Turn unit off and recharge or replace battery (See <i>Recharging & Replacing the Battery</i> , page 4-8.)

Calibration Error Processing

A Calibration Error indicates a failure during the measurement of the internal moisture references. During Autocal, internal references are read repeatedly and the Series 35 IS compares measured values to a table of acceptable factory calibration values. The system calculates and corrects any deviation from the factory values. If a reference falls outside the acceptable range, a CAL ERROR message appears.

If you attempt to display data after the system experiences a calibration error, the display reads “CAL ERROR DP/°C.”

Note: *The units displayed, (e.g., °C) depends on the previously selected measurement units.*

Recharging and Replacing the Battery

Portable battery-powered units, with and without internal sample systems, require a battery charger that accepts either 110 VAC or 220 VAC input, and outputs 12 volts DC at a maximum current of 500 mA.

A fully charged Series 35 IS battery pack provides continuous operation for between 12 hours (with the backlight on) and 120 hours (with the backlight off). When the battery charge is low (usually below 5.85 volts), the screen blinks and displays the “Supply Low” prompt. This display remains on the screen for approximately one (1) hour before the Series 35 IS shuts down the electronics.

Recharging the Battery

GE Panametrics supplies a suitable charger with each Series 35 IS battery-powered unit.

Caution!

Make all AC connections to charge the battery in a non-hazardous, general-purpose area.

If the battery is low, move the Series 35 IS to a non-hazardous area and connect the charger to the unit. While the battery is being charged, the unit may be turned back on. The Series 35 IS displays “Loading...” while it initializes, then returns to whatever it displayed when it was turned off.

The Series 35 IS begins charging when you plug it into AC power. A full charge takes 16 hours. Use the following steps to recharge the battery.

1. Turn the unit off.
2. Plug the charger into the line power.
3. Plug the other end of the charger into the connector on the left side of the electronics unit.
4. Charge the unit for 16 hours.

Note: *The unit can continue to operate while its batteries are being charged.*

!WARNING!

Do not connect the Series 35 IS to a charger in a hazardous environment.

Replacing the Battery

If the battery of your Series 35 IS does not hold a charge for a full 12 hours after 16 hours of recharging, the battery needs replacement. Contact the factory for a new one.

Always store the Series 35 IS lead acid battery at room temperature ($\approx 25^{\circ}\text{C}$). Table 4-3 below illustrates how periods of storage deplete battery capacity.

Table 4-3: Battery Capacity in Storage

Storage Time at Room Temperature	Capacity
3 months	91%
6 months	82%
12 months	64%

Refer to Figure 4-1 on page 4-11 and complete the following steps to remove the old battery:

Note: *The only tools needed to change the Series 35 IS battery are a standard screwdriver to open the case and a 1/8" Allen wrench to remove the battery cover.*

1. Loosen the two quarter-turn screws on the back of the Series 35 IS cover. Remove the cover by lifting it off the unit from back to front.
2. Disconnect the ribbon cable that connects the encapsulated charger board to connector J3 on the back of the main printed circuit board, which is mounted in the cover of the Series 35 IS. Refer to Figure 4-1 on page 4-11 and Figure 4-2 on page 4-15.

Note: *Pin 1 of connector J3 is clearly labeled on the circuit board, and the side of the ribbon cable that must align with pin 1 has been marked as such at the factory.*

Replacing the Battery (cont.)

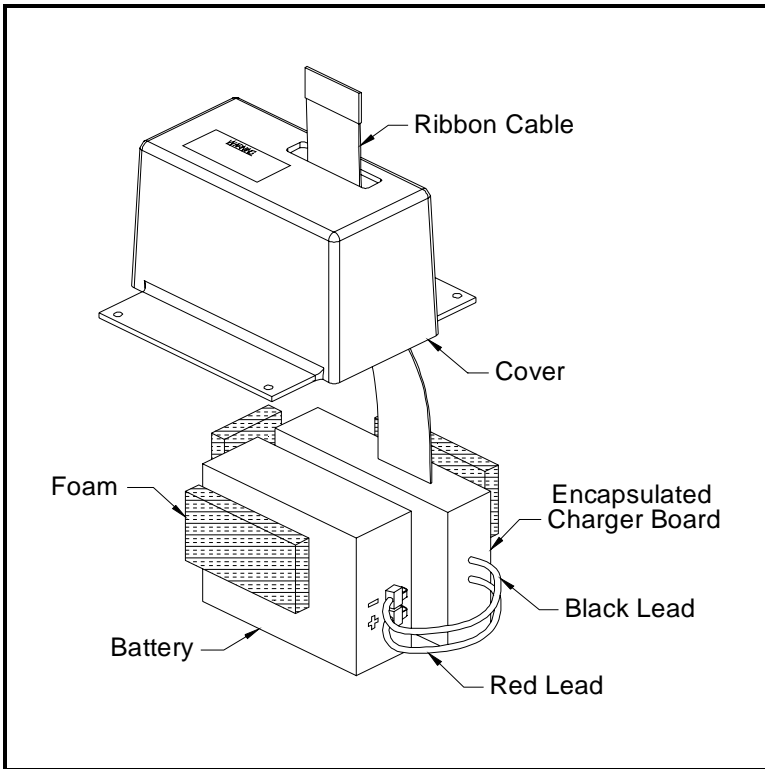

Figure 4-1: Battery Pack with Charger Board

3. Use the Allen wrench to remove the four socket head cap screws that secure the battery cover to the base plate.
4. Lift the battery cover out of the electronics unit and slide the battery and the encapsulated charger board out of the battery cover.
5. Disconnect the leads from the encapsulated charger board by removing the two crimp pins from the battery terminals (take care not to damage the wires).

Replacing the Battery (cont.)

Refer to Figure 4-1 on page 4-11 and Figure 4-2 on page 4-15 and use the following steps to install the new battery:

1. Connect the two (2) leads from the encapsulated charger board to the new battery by pressing the crimp pins on the ends of the leads onto the terminals of the new battery.

IMPORTANT: *Make sure the red lead is connected to the “+” battery terminal and the black lead is connected to the “-” battery terminal.*

2. Insert the new battery and the encapsulated charger board into the battery cover. Make sure the ribbon cable is threaded through the slot in the battery cover.
3. Place the battery pack assembly into position in the electronics unit, and secure the battery cover to the base plate with the four (4) screws previously removed.
4. Reconnect the ribbon cable from the encapsulated charger board to connector J3 on the back of the main printed circuit board. Make sure that the side of the ribbon cable with the factory marking is aligned with the end of connector J3 that is labeled as pin 1.
5. Replace the Series 35 IS cover by attaching it to the unit from front to back. Tighten the two quarter-turn screws on the back of the cover.

Replacing the User Program

The user program is stored on an EPROM (Erasable Programmable Read Only Memory) chip. The EPROM is located on the main printed circuit board (No. 703-1262), which is mounted in the cover of the Series 35 IS electronics unit.

You must do the following to replace the user program:

- Remove the main printed circuit board.
- Replace the EPROM.
- Reinstall the main printed circuit board.

Refer to the following sections to replace the user program. Contact GE Panametrics if your unit contains a main circuit board with a registration number other than 703-1262.

Removing the Circuit Board

See Figure 4-2 on page 4-15 to locate the cable connections on the back (non-component side) of the main printed circuit board.

Note: *The main printed circuit board is mounted on the inside of the electronics cover.*

Caution!

Remove the circuit board to a non-hazardous area.

1. Turn the power off and, if applicable, unplug the unit.

!WARNING!

You must turn off and unplug the Series 35 IS before continuing with the following steps.

2. Discharge static electricity from your body before touching the Series 35 IS enclosure.
3. Open the Series 35 IS enclosure by loosening the two quarter-turn screws on the back of the unit and gently lifting the cover off from back to front.

There are five (5) detachable cables plugged into the back (non-component side) of the printed circuit board. Refer to Table 4-4 below for a description of these cables.

Table 4-4: Printed Circuit Board Cables

Cable Type	Connector	Source
2-Wire	J2	ON/OFF Switch
16-conductor Ribbon	J3	Battery Pack
14-conductor Ribbon	J4	Display Board
2-Wire	J5	Display Backlight
9-conductor Ribbon	J6	Keypad

Removing the Circuit Board (cont.)

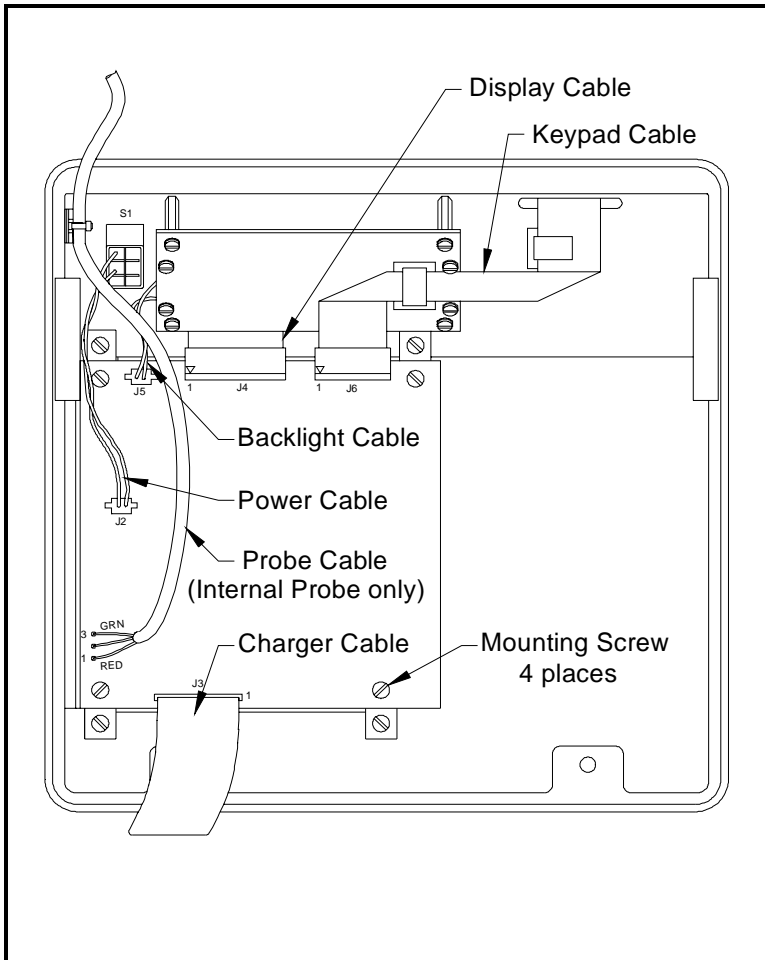

Figure 4-2: Rear of PC Board - Cable Connections

Note: Be careful not to pull on the cables while removing the cover.

IMPORTANT: Before disconnecting the ribbon cables, mark the side of each cable that is near pin 1 of its circuit board connector. Pin 1 is clearly labeled on the circuit board for J3, J4 and J6. See Figure 4-2 (above).

Removing the Circuit Board (cont.)

4. Disconnect the five (5) cables from the J2, J3, J4, J5, and J6 connectors on the back (non-component side) of the main printed circuit board.

IMPORTANT: *To maintain good contact at each terminal block and to avoid damaging the pins on a connector, pull the connector straight off (not at an angle).*

5. If your Series 35 IS includes a self-contained sample system, you must disconnect the moisture probe cable from the probe at this time (refer to *Installing a Probe into a Sample System* in Chapter 2).
6. Remove any external connections to the Series 35 IS. These may include: the battery charger, an RS232 interface cable and/or a moisture probe cable from an external sample system.
7. Remove the main printed circuit board from inside the cover by unscrewing the four screws that fasten the circuit board to its mounting bracket.
8. Turn the circuit board over to access the EPROM on the component side of the circuit board.

Note: *To replace the circuit board, refer to Replacing the Circuit Board on page 4-19.*

Replacing the EPROM

Caution!

EPROMs can be damaged by static electricity. Be sure to discharge any static electricity from your body before handling the EPROM.

Replace the EPROM by carefully completing the following steps in the order presented.

1. Refer to Figure 4-3 on page 4-18 to locate the EPROM (labeled U18) on the component side of the main printed circuit board.
2. Use a chip puller to remove the EPROM. If you do not have a chip puller, use a small screwdriver to carefully wedge the chip out of its mounting. Be sure none of the EPROM legs breaks off in the socket.
3. Insert the new EPROM into the socket labeled U18, making sure the notch on the EPROM aligns with the notch on the socket. See Figure 4-3 on page 4-18.
4. If all the EPROM legs do not align with the corresponding holes in the socket, gently remove the EPROM and place it on its side (where the legs are located) on a flat surface. Then, gently roll the EPROM toward the legs to bend the row of legs slightly inward.

Caution!

The EPROM legs are very delicate and may snap off if they are bent too far or too many times.

5. Repeat step 4 for the legs on the opposite side of the EPROM. Then, insert the EPROM back into its socket, making sure that the notch on the EPROM aligns with the notch on the socket.

Replacing the EPROM (cont.)

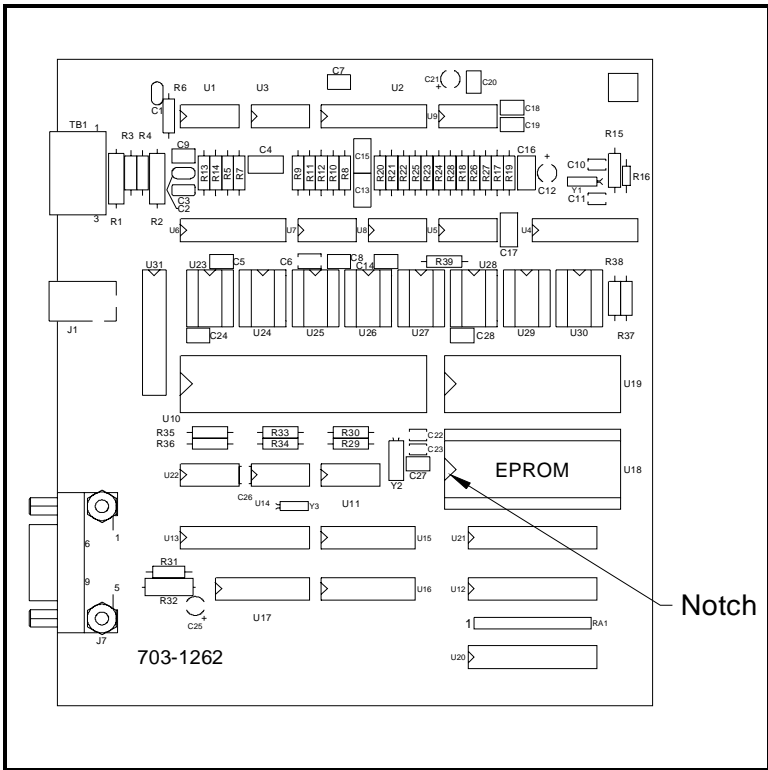

Figure 4-3: EPROM (U18) Notch Location

6. Gently press the EPROM into place until it is fully seated in the socket, making sure not to bend or break any of the legs. Repeat steps 4 and 5 if necessary.

Caution!

Do not force the EPROM into the socket. If the EPROM does not seat easily, check for bent legs or legs that do not properly align with the corresponding holes in the socket.

Replacing the Circuit Board

1. Turn the circuit board over so that the component side (the side with the EPROM) of the board faces the inside of the Series 35 IS cover, and position the circuit board on the mounting bracket in the cover.

Note: *When orienting the circuit board within the electronics unit cover, make certain that the RS232 connector, battery charger jack and external probe cable connector are properly inserted into the cutouts in the side panel of the cover.*

2. Install and tighten the four (4) previously removed bracket screws and washers in the corners of the circuit board.
3. If your unit includes a self-contained sample system, reconnect the moisture probe cable to the probe at this time (see Chapter 2, *Installing a Probe into a Sample System*).
4. Reconnect the five (5) cables to the J2, J3, J4, J5, and J6 connectors on the back (non-component side) of the circuit board. The cables that connect to J2 and J5 are polarized and can only be inserted in the correct orientation. However, the three (3) ribbon cables could be rotated 180° from the proper alignment. Therefore, make sure that the previously applied pin 1 marking on each ribbon cable aligns with the pin 1 label on the circuit board at the J3, J4 and J6 connectors.

IMPORTANT: *To maintain good contact at each terminal block and to avoid damaging the pins on a connector, push the connector straight on (not at an angle).*

5. Replace the Series 35 IS cover by attaching it to the unit from front to back. Tighten the two quarter-turn screws on the back of the unit.
6. Reconnect any external cables such as the battery charger, an RS232 interface cable and/or the moisture probe cable from an external sample system.

Replacing and Recalibrating the Moisture Probe

For maximum accuracy you should send probes back to the factory for recalibration every six months to one year, depending on the application. Under severe conditions you should send the probes back for recalibration more frequently. Contact a GE Panametrics applications engineer for the recommended calibration frequency for your application.

When you receive a new or recalibrated probe, make sure to install and connect it as described in Chapter 2, *Installing a Probe into a Sample System*. Once you have installed and connected the probes, enter the calibration data as described in Chapter 3, *Entering Calibration Data*.

Note: *An individualized Calibration Data Sheet, containing the corresponding probe serial number, accompanies each probe.*

Chapter 5

Specifications

The Moisture Monitor Series 35 IS has been designed to meet or exceed the specifications listed in this chapter. The information has been divided into the following two categories:

- Electrical Specifications [page 5-2]
- General Specifications [page 5-3]

Electrical Specifications

Functions:

Dew Point:

PPMv in gases at constant pressure
(pressure by programmable constant).

Inputs:

Moisture:

Single input via M-Series probe connected to main board.
Probe may be remotely located up to 100 m (330 ft) from
electronic console, except for units with self-contained
internal sample systems.

Intrinsic Safety:

BASEEFA-certified intrinsically safe probe and cable.
ISSEP-certified intrinsically safe hygrometer (Code: EEx ia
IICT4)

Computer-Enhanced Response:

Optional

Display Units:

Dew/frost point temperature: °C, °F, PPMv, MH

Pressure: psi(g), bar, kPa(g), kg/cm²(g)

Power Requirements:

AC power supply:

Voltage: Specify as 100, 120, 230, or 240 VAC

Frequency: Specify as 50/60 Hz

12V Charger Input Power: 5 watts, maximum

Rechargeable Battery Pack: Battery power for 12-hour
operation (with backlight) or 120-hour operation (without
backlight)

General Specifications

Temperature:

Operating: 0° to 60°C (32° to 140°F)

Storage: -20° to 70°C (-22° to 158°F).

Configurations:

Battery Powered

Battery Powered with self-contained Sample System.

Dew/Frost Point Temperature:

Overall calibration range capability:

+60° to -110°C (+140° to -166°F).

Available Calibration Range Options:

Standard Calibration Range:

20° to -80°C with data to -110°C

(68° to -112°F with data to -166°F)

Extended High Calibration Range:

60° to -80°C with data to -110°C

(140° to -112°F with data to -166°F)

Accuracy:

±2°C from 60° to -65°C (140° to -85°F)

±3°C from -66° to -110°C (-86° to -166°F)

Repeatability:

±0.5°C from 60° to -65°C (140° to -85°F)

±1.0°C from -66° to -110°C (-86° to -166°F)

General Specifications (cont.)

Response Time:

5 sec for 63% of a step change in moisture content in either wet up or dry down cycle

Gas Flow Range:

From static to 10,000-cm/s linear velocity at 1 atm

Sensor Type:

GE Panametrics M-Series thin-film aluminum oxide

Traceability:

Every moisture probe is individually computer-calibrated against known moisture concentration standards, traceable to National Institute of Standards and Technology (NIST) or National Physical Lab, U.K. (NPL) as approved by Irish Laboratory Accreditation Board (ILAB).

Temperature:

Operating and Storage:
-110° to +70°C (-166° to 158°F)

@LEVEL4A = Pressure:

Operating:
5 microns Hg to 5000 psig

Appendix A

Application of the Hygrometer

This appendix contains general information about moisture monitoring techniques. System contaminants, moisture probe maintenance, process applications and other considerations for ensuring accurate moisture measurements are discussed.

The following specific topics are covered:

- Moisture Monitor Hints [page A-2]
- Contaminants [page A-7]
- Aluminum Oxide Probe Maintenance [page A-9]
- Corrosive Gases and Liquids [page A-11]
- Materials of Construction [page A-12]
- Calculations and Useful Formulas in Gas Applications [page A-13]
- Liquid Applications [page A-27]
- Empirical Calibrations [page A-34]
- Solid Applications [page A-40]

Moisture Monitor Hints

GE Panametrics hygrometers, using aluminum oxide moisture probes, have been designed to reliably measure the moisture content of both gases and liquids. The measured dew point will be the real dew point of the system at the measurement location and at the time of measurement. However, no moisture sensor can determine the origin of the measured moisture content. In addition to the moisture content of the fluid to be analyzed, the water vapor pressure at the measurement location may include components from sources such as: moisture from the inner walls of the piping; external moisture through leaks in the piping system; and trapped moisture from fittings, valves, filters, etc. Although these sources may cause the measured dew point to be higher than expected, it is the actual dew point of the system at the time of measurement.

One of the major advantages of the GE Panametrics hygrometer is that it can be used for *in situ* measurements (i.e. the sensor element is designed for installation directly within the region to be measured). As a result, the need for complex sample systems that include extensive piping, manifolds, gas flow regulators and pressure regulators is eliminated or greatly reduced. Instead, a simple sample system to reduce the fluid temperature, filter contaminants and facilitate sensor removal is all that is needed.

Whether the sensor is installed *in situ* or in a remote sampling system, the accuracy and speed of measurement depend on the piping system and the dynamics of the fluid flow. Response times and measurement values will be affected by the degree of equilibrium reached within system. Factors such as gas pressure, flow rate, materials of construction, length and diameter of piping, etc. will greatly influence the measured moisture levels and the response times.

Assuming that all secondary sources of moisture have been eliminated and the sample system has been allowed to come to equilibrium, then the measured dew point will equal the actual dew point of the process fluid.

Moisture Monitor Hints (cont.)

Some of the most frequently encountered problems associated with moisture monitoring sample systems include:

- the moisture content value changes as the total gas pressure changes
- the measurement response time is very slow
- the dew point changes as the fluid temperature changes
- the dew point changes as the fluid flow rate changes.

GE Panametrics hygrometers measure only water vapor pressure. In addition, the instrument has a very rapid response time and it is not affected by changes in fluid temperature or fluid flow rate. If any of the above situations occur, then they are almost always caused by a defect in the sample system. The moisture sensor itself can not lead to such problems.

Pressure

GE Panametrics hygrometers can accurately measure dew points under pressure conditions ranging from vacuums as low as a few microns of mercury up to pressures of 5000 psig. The calibration data supplied with the moisture probe is directly applicable over this entire pressure range, without correction.

Note: *Although the moisture probe calibration data is supplied as meter reading vs. dew point, it is important to remember that the moisture probe responds only to water vapor pressure.*

When a gas is compressed, the partial pressures of all the gaseous components are proportionally increased. Conversely, when a gas expands, the partial pressures of the gaseous components are proportionally decreased. Therefore, increasing the pressure on a closed aqueous system will increase the vapor pressure of the water, and hence, increase the dew point. This is not just a mathematical artifact. The dew point of a gas with 1000 PPMv of water at 200 psig will be considerably higher than the dew point of a gas with 1000 PPMv of water at 1 atm. Gaseous water vapor will actually condense to form liquid water at a higher temperature at the 200 psig pressure than at the 1 atm pressure. Thus, if the moisture probe is exposed to pressure changes, the measured dew point will be altered by the changed vapor pressure of the water.

It is generally advantageous to operate the hygrometer at the highest possible pressure, especially at very low moisture concentrations. This minimizes wall effects and results in higher dew point readings, which increases the sensitivity of the instrument.

Response Time

The response time of the GE Panametrics standard M Series Aluminum Oxide Moisture Sensor is very rapid - a step change of 63% in moisture concentration will be observed in approximately 5 seconds. Thus, the observed response time to moisture changes is, in general, limited by the response time of the sample system as a whole. Water vapor is absorbed tenaciously by many materials, and a large, complex processing system can take several days to “dry down” from atmospheric moisture levels to dew points of less than -60°C . Even simple systems consisting of a few feet of stainless steel tubing and a small chamber can take an hour or more to dry down from dew points of $+5^{\circ}\text{C}$ to -70°C . The rate at which the system reaches equilibrium will depend on flow rate, temperature, materials of construction and system pressure. Generally speaking, an increase in flow rate and/or temperature will decrease the response time of the sample system.

To minimize any adverse affects on response time, the preferred materials of construction for moisture monitoring sample systems are stainless steel, Teflon[®] and glass. Materials to be avoided include rubber elastomers and related compounds.

Temperature

The GE Panametrics hygrometer is largely unaffected by ambient temperature. However, for best results, it is recommended that the ambient temperature be at least 10°C higher than the measured dew point, up to a maximum of 70°C . Because an ambient temperature increase may cause water vapor to be desorbed from the walls of the sample system, it is possible to observe a diurnal change in moisture concentration for a system exposed to varying ambient conditions. In the heat of the day, the sample system walls will be warmed by the ambient air and an off-gassing of moisture into the process fluid, with a corresponding increase in measured moisture content, will occur. The converse will happen during the cooler evening hours. This effect should not be mistakenly interpreted as indicating that the moisture probe has a temperature coefficient.

Flow Rate

GE Panametrics hygrometers are unaffected by the fluid flow rate. The moisture probe is not a mass sensor but responds only to water vapor pressure. The moisture probe will operate accurately under both static and dynamic fluid flow conditions. In fact, the specified maximum fluid linear velocity of 10,000 cm/sec for The M Series Aluminum Oxide Moisture Sensor indicates a mechanical stability limitation rather than a sensitivity to the fluid flow rate.

If the measured dew point of a system changes with the fluid flow rate, then it can be assumed that off-gassing or a leak in the sample system is causing the variation. If secondary moisture is entering the process fluid (either from an ambient air leak or the release of previously absorbed moisture from the sample system walls), an increase in the flow rate of the process fluid will dilute the secondary moisture source. As a result, the vapor pressure will be lowered and a lower dew point will be measured.

Note: *Refer to the Specifications chapter in this manual for the maximum allowable flow rate for the instrument.*

Contaminants

Industrial gases and liquids often contain fine particulate matter. Particulates of the following types are commonly found in such process fluids:

- carbon particles
- salts
- rust particles
- polymerized substances
- organic liquid droplets
- dust particles
- molecular sieve particles
- alumina dust

For convenience, the above particulates have been divided into three broad categories. Refer to the appropriate section for a discussion of their affect on the GE Panametrics moisture probe.

Non-Conductive Particulates

Note: *Molecular sieve particles, organic liquid droplets and oil droplets are typical of this category.*

In general, the performance of the moisture probe will not be seriously hindered by the condensation of non-conductive, non-corrosive liquids. However, a slower response to moisture changes will probably be observed, because the contaminating liquid barrier will decrease the rate of transport of the water vapor to the sensor and reduce its response time.

Particulate matter with a high density and/or a high flow rate may cause abrasion or pitting of the sensor surface. This can drastically alter the calibration of the moisture probe and, in extreme cases, cause moisture probe failure. A stainless steel shield is supplied with the moisture probe to minimize this effect, but in severe cases, it is advisable to install a Teflon® or stainless steel filter in the fluid stream.

Non-Conductive Particulates (cont.)

On rare occasions, non-conductive particulate material may become lodged under the contact arm of the sensor, creating an open circuit. If this condition is suspected, refer to the *Probe Cleaning Procedure* section of this appendix for the recommended cleaning procedure.

Conductive Particulates

Note: *Metallic particles, carbon particles and conductive liquid droplets are typical of this category.*

Since the hygrometer reading is inversely proportional to the impedance of the sensor, a decrease in sensor impedance will cause an increase in the meter reading. Thus, trapped conductive particles across the sensor leads or on the sensor surface, which will decrease the sensor impedance, will cause an erroneously high dew point reading. The most common particulates of this type are carbon (from furnaces), iron scale (from pipe walls) and glycol droplets (from glycol-based dehydrators).

If the system contains conductive particulates, it is advisable to install a Teflon® or stainless steel filter in the fluid stream.

Corrosive Particulates

Note: *Sodium chloride and sodium hydroxide particulates are typical of this category.*

Since the active sensor element is constructed of aluminum, any material that corrodes aluminum will deleteriously affect the operation of the moisture probe. Furthermore, a combination of this type of particulate with water will cause pitting or severe corrosion of the sensor element. In such instances, the sensor cannot be cleaned or repaired and the probe must be replaced.

Obviously, the standard moisture probe can not be used in such applications unless the complete removal of such part by adequate filtration is assured.

Aluminum Oxide Probe Maintenance

Other than periodic calibration checks, little or no routine moisture probe maintenance is required. However, as discussed in the previous section, any electrically conductive contaminant trapped on the aluminum oxide sensor will cause inaccurate moisture measurements. If such a situation develops, return of the moisture probe to the factory for analysis and recalibration is recommended. However, in an emergency, cleaning of the moisture probe in accordance with the following procedure may be attempted by a qualified technician or chemist.

IMPORTANT: *Moisture probes must be handled carefully and cannot be cleaned in any fluid which will attack its components. The probe's materials of construction are Al, Al₂O₃, nichrome, gold, stainless steel, glass and Viton[®] A. Also, the sensor's aluminum sheet is very fragile and can be easily bent or distorted. Do not permit anything to touch it!*

The following items will be needed to properly complete the moisture probe cleaning procedure:

- approximately 300 ml of reagent grade hexane or toluene
- approximately 300 ml of distilled (not deionized) water
- two glass containers to hold above liquids (metal containers should not be used).

To clean the moisture probe, complete the following steps:

1. Record the dew point of the ambient air.
2. Making sure not to touch the sensor, carefully remove the protective shield from the sensor.
3. Soak the sensor in the distilled water for ten (10) minutes. Be sure to avoid contact with the bottom and the walls of the container!

Aluminum Oxide Probe Maintenance (cont.)

4. Remove the sensor from the distilled water and soak it in the clean container of hexane or toluene for ten (10) minutes. Again, avoid all contact with the bottom and the walls of the container!
5. Remove the sensor from the hexane or toluene, and place it face up in a low temperature oven set at $50^{\circ}\text{C} \pm 2^{\circ}\text{C}$ ($122^{\circ}\text{F} \pm 4^{\circ}\text{F}$) for 24 hours.
6. Repeat steps 3-5 for the protective shield. During this process, swirl the shield in the solvents to ensure the removal of any contaminants that may have become embedded in the porous walls of the shield.
7. Carefully replace probe's protective shield, making sure not to touch the sensor.
8. Connect the probe cable to the probe, and record the dew point of the ambient air, as in step 1. Compare the two recorded dew point readings to determine if the reading after cleaning is a more accurate value for the dew point of the ambient atmosphere.
9. If the sensor is in proper calibration ($\pm 2^{\circ}\text{C}$ accuracy), reinstall the probe in the sample cell and proceed with normal operation of the hygrometer.
10. If the sensor is not in proper calibration, repeat steps 1-9, using time intervals 5 times those used in the previous cleaning cycle. Repeat this procedure until the sensor is in proper calibration.

A trained laboratory technician should determine if all electrically conductive compounds have been removed from the aluminum oxide sensor and that the probe is properly calibrated. Probes which are not in proper calibration must be recalibrated. It is recommended that all moisture probes be recalibrated by GE Panametrics approximately once a year, regardless of the probe's condition.

Corrosive Gases And Liquids

GE Panametrics M Series Aluminum Oxide Moisture Sensors have been designed to minimize the affect of corrosive gases and liquids. As indicated in the *Materials of Construction* section of this appendix, no copper, solder or epoxy is used in the construction of these sensors. The moisture content of corrosive gases such as H₂S, SO₂, cyanide containing gases, acetic acid vapors, etc. can be measured directly.

Note: *Since the active sensor is aluminum, any fluid which corrodes aluminum will affect the sensor's performance.*

By observing the following precautions, the moisture probe may be used successfully and economically:

1. The moisture content of the corrosive fluid must be 10 PPMv or less at 1 atmosphere, or the concentration of the corrosive fluid must be 10 PPMv or less at 1 atmosphere.
2. The sample system must be pre-dried with a dry inert gas, such as nitrogen or argon, prior to introduction of the fluid stream. Any adsorbed atmospheric moisture on the sensor will react with the corrosive fluid to cause pitting or corrosion of the sensor.
3. The sample system must be purged with a dry inert gas, such as nitrogen or argon, prior to removal of the moisture probe. Any adsorbed corrosive fluid on the sensor will react with ambient moisture to cause pitting or corrosion of the sensor.
4. Operate the sample system at the lowest possible gas pressure.

Using the precautions listed above, the hygrometer has been used to successfully measure the moisture content in such fluids as hydrochloric acid, sulfur dioxide, chlorine and bromine.

Materials of Construction

M1 and M2 Sensors:

<i>Sensor Element:</i>	99.99% aluminum, aluminum oxide, gold, Nichrome, A6
<i>Back Wire:</i>	316 stainless steel
<i>Contact Wire:</i>	gold, 304 stainless steel
<i>Front Wire:</i>	316 stainless steel
<i>Support:</i>	Glass (Corning 9010)

Electrical Connector:

<i>Pins:</i>	Al 152 Alloy (52% Ni)
<i>Glass:</i>	Corning 9010
<i>Shell:</i>	304L stainless steel
<i>O-Ring:</i>	silicone rubber
<i>Threaded Fitting:</i>	304 stainless steel
<i>O-Ring:</i>	Viton® A
<i>Cage:</i>	308 stainless steel
<i>Shield:</i>	304 stainless steel

Calculations and Useful Formulas in Gas Applications

A knowledge of the dew point of a system enables one to calculate all other moisture measurement parameters. The most important fact to recognize is that *for a particular dew point there is one and only one equivalent vapor pressure.*

Note: *The calibration of GE Panametrics moisture probes is based on the vapor pressure of liquid water above 0°C and frost below 0°C. GE Panametrics moisture probes are never calibrated with supercooled water.*

Caution is advised when comparing dew points measured with a GE Panametrics hygrometer to those measured with a mirror type hygrometer, since such instruments may provide the dew points of supercooled water.

As stated above, the dew/frost point of a system defines a unique partial pressure of water vapor in the gas. Table A-1, which lists water vapor pressure as a function of dew point, can be used to find either the saturation water vapor pressure at a known temperature or the water vapor pressure at a specified dew point. In addition, all definitions involving *humidity* can then be expressed in terms of the water vapor pressure.

Nomenclature

The following symbols and units are used in the equations that are presented in the next few sections:

- RH = relative humidity
- T_K = temperature ($^{\circ}\text{K} = ^{\circ}\text{C} + 273$)
- T_R = temperature ($^{\circ}\text{R} = ^{\circ}\text{F} + 460$)
- PPM_v = parts per million by volume
- PPM_w = parts per million by weight
- M_w = molecular weight of water (18)
- M_T = molecular weight of carrier gas

Nomenclature (cont.)

- P_S = saturation vapor pressure of water at the prevailing temperature (mm of Hg)
- P_W = water vapor pressure at the measured dew point (mm of Hg)
- P_T = total system pressure (mm of Hg)

Parts per Million by Volume

The water concentration in a system, in parts per million by volume, is proportional to the ratio of the water vapor partial pressure to the total system pressure:

$$\text{PPM}_V = \frac{P_W}{P_T} \times 10^6 \quad (1)$$

In a closed system, increasing the total pressure of the gas will proportionally increase the partial pressures of the various components. The relationship between dew point, total pressure and PPM_V is provided in nomographic form in Figure A-1.

Note: *The nomograph shown in Figure A-1 is applicable only to gases. Do not apply it to liquids.*

To compute the moisture content for any ideal gas at a given pressure, refer to Figure A-1. Using a straightedge, connect the dew point (as measured with the GE Panametrics' Hygrometer) with the known system pressure. Read the moisture content in PPM_V where the straightedge crosses the moisture content scale.

Typical Problems

1. Find the water content in a nitrogen gas stream, if a dew point of -20°C is measured and the pressure is 60 psig.

Solution: In Figure A-1, connect 60 psig on the Pressure scale with -20°C on the Dew/Frost Point scale. Read **200 PPM_V** , on the Moisture Content scale.

Parts per Million by Volume (cont.)

- Find the expected dew/frost point for a helium gas stream having a measured moisture content of 1000 PPM_V and a system pressure of 0.52 atm.

Solution: In Figure A-1, connect 1000 PPM_V on the Moisture Content scale with 0.52 atm on the Pressure scale. Read the expected frost point of **-27°C** on the Dew/Frost Point scale.

Parts per Million by Weight

The water concentration in the gas phase of a system, in parts per million by weight, can be calculated directly from the PPM_V and the ratio of the molecular weight of water to that of the carrier gas as follows:

$$\text{PPM}_{\text{W}} = \text{PPM}_{\text{V}} \times \frac{M_{\text{W}}}{M_{\text{T}}} \quad (2)$$

Relative Humidity

Relative humidity is defined as the ratio of the actual water vapor pressure to the saturation water vapor pressure at the prevailing ambient temperature, expressed as a percentage.

$$\text{RH} = \frac{P_{\text{W}}}{P_{\text{S}}} \times 100 \quad (3)$$

- Find the relative humidity in a system, if the measured dew point is 0°C and the ambient temperature is +20°C.

Solution: From Table A-1, the water vapor pressure at a dew point of 0°C is 4.579 mm of Hg and the saturation water vapor pressure at an ambient temperature of +20°C is 17.535 mm of Hg. Therefore, the relative humidity of the system is $100 \times 4.579/17.535 = \mathbf{26.1\%}$.

Weight of Water per Unit Volume of Carrier Gas

Three units of measure are commonly used in the gas industry to express the weight of water per unit volume of carrier gas. They all represent a vapor density and are derivable from the vapor pressure of water and the Perfect Gas Laws. Referenced to a temperature of 60°F and a pressure of 14.7 psia, the following equations may be used to calculate these units:

$$\frac{\text{mg of water}}{\text{liter of gas}} = 289 \times \frac{P_W}{T_K} \quad (4)$$

$$\frac{\text{lb of water}}{\text{ft}^3 \text{ of gas}} = 0.0324 \times \frac{P_W}{T_R} \quad (5)$$

$$\frac{\text{lb of water}}{\text{MMSCF of gas}} = \frac{\text{PPM}_V}{21.1} = \frac{10^6 \times P_W}{21.1 \times P_T} \quad (6)$$

Note: *MMSCF* is an abbreviation for a “million standard cubic feet” of carrier gas.

Weight of Water per Unit Weight of Carrier Gas

Occasionally, the moisture content of a gas is expressed in terms of the weight of water per unit weight of carrier gas. In such a case, the unit of measure defined by the following equation is the most commonly used:

$$\frac{\text{grains of water}}{\text{lb of gas}} = 7000 \times \frac{M_W \times P_W}{M_T \times P_T} \quad (7)$$

For ambient air at 1 atm of pressure, the above equation reduces to the following:

$$\frac{\text{grains of water}}{\text{lb of gas}} = 5.72 \times P_W \quad (8)$$

Table A-1: Vapor Pressure of Water

Note: *If the dew/frost point is known, the table will yield the partial water vapor pressure (P_W) in mm of Hg. If the ambient or actual gas temperature is known, the table will yield the saturated water vapor pressure (P_S) in mm of Hg.*

Water Vapor Pressure Over Ice

Temp. (°C)	0	2	4	6	8
-90	0.000070	0.000048	0.000033	0.000022	0.000015
-80	0.00040	0.00029	0.00020	0.00014	0.00010
-70	0.00194	0.00143	0.00105	0.00077	0.00056
-60	0.00808	0.00614	0.00464	0.00349	0.00261
-50	0.02955	0.0230	0.0178	0.0138	0.0106
-40	0.0966	0.0768	0.0609	0.0481	0.0378
-30	0.2859	0.2318	0.1873	0.1507	0.1209
Temp. (°C)	0.0	0.2	0.4	0.6	0.8
-29	0.317	0.311	0.304	0.298	0.292
-28	0.351	0.344	0.337	0.330	0.324
-27	0.389	0.381	0.374	0.366	0.359
-26	0.430	0.422	0.414	0.405	0.397
-25	0.476	0.467	0.457	0.448	0.439
-24	0.526	0.515	0.505	0.495	0.486
-23	0.580	0.569	0.558	0.547	0.536
-22	0.640	0.627	0.615	0.603	0.592
-21	0.705	0.691	0.678	0.665	0.652

Table A-1: Vapor Pressure of Water (cont.)

Water Vapor Pressure Over Ice (cont.)					
Temp. (°C)	0.0	0.2	0.4	0.6	0.8
-20	0.776	0.761	0.747	0.733	0.719
-19	0.854	0.838	0.822	0.806	0.791
-18	0.939	0.921	0.904	0.887	0.870
-17	1.031	1.012	0.993	0.975	0.956
-16	1.132	1.111	1.091	1.070	1.051
-15	1.241	1.219	1.196	1.175	1.153
-14	1.361	1.336	1.312	1.288	1.264
-13	1.490	1.464	1.437	1.411	1.386
-12	1.632	1.602	1.574	1.546	1.518
-11	1.785	1.753	1.722	1.691	1.661
-10	1.950	1.916	1.883	1.849	1.817
-9	2.131	2.093	2.057	2.021	1.985
-8	2.326	2.285	2.246	2.207	2.168
-7	2.537	2.493	2.450	2.408	2.367
-6	2.765	2.718	2.672	2.626	2.581
-5	3.013	2.962	2.912	2.862	2.813
-4	3.280	3.225	3.171	3.117	3.065
-3	3.568	3.509	3.451	3.393	3.336
-2	3.880	3.816	3.753	3.691	3.630
-1	4.217	4.147	4.079	4.012	3.946
0	4.579	4.504	4.431	4.359	4.287

Table A-1: Vapor Pressure of Water (cont.)

Aqueous Vapor Pressure Over Water					
Temp. (°C)	0.0	0.2	0.4	0.6	0.8
0	4.579	4.647	4.715	4.785	4.855
1	4.926	4.998	5.070	5.144	5.219
2	5.294	5.370	5.447	5.525	5.605
3	5.685	5.766	5.848	5.931	6.015
4	6.101	6.187	6.274	6.363	6.453
5	6.543	6.635	6.728	6.822	6.917
6	7.013	7.111	7.209	7.309	7.411
7	7.513	7.617	7.722	7.828	7.936
8	8.045	8.155	8.267	8.380	8.494
9	8.609	8.727	8.845	8.965	9.086
10	9.209	9.333	9.458	9.585	9.714
11	9.844	9.976	10.109	10.244	10.380
12	10.518	10.658	10.799	10.941	11.085
13	11.231	11.379	11.528	11.680	11.833
14	11.987	12.144	12.302	12.462	12.624
15	12.788	12.953	13.121	13.290	13.461
16	13.634	13.809	13.987	14.166	14.347
17	14.530	14.715	14.903	15.092	15.284
18	15.477	15.673	15.871	16.071	16.272
19	16.477	16.685	16.894	17.105	17.319
20	17.535	17.753	17.974	18.197	18.422
21	18.650	18.880	19.113	19.349	19.587
22	19.827	20.070	20.316	20.565	20.815
23	21.068	21.324	21.583	21.845	22.110
24	22.377	22.648	22.922	23.198	23.476

Table A-1: Vapor Pressure of Water (cont.)

Aqueous Vapor Pressure Over Water (cont.)					
Temp. (°C)	0.0	0.2	0.4	0.6	0.8
25	23.756	24.039	24.326	24.617	24.912
26	25.209	25.509	25.812	26.117	26.426
27	26.739	27.055	27.374	27.696	28.021
28	28.349	28.680	29.015	29.354	29.697
29	30.043	30.392	30.745	31.102	31.461
30	31.824	32.191	32.561	32.934	33.312
31	33.695	34.082	34.471	34.864	35.261
32	35.663	36.068	36.477	36.891	37.308
33	37.729	38.155	38.584	39.018	39.457
34	39.898	40.344	40.796	41.251	41.710
35	42.175	42.644	43.117	43.595	44.078
36	44.563	45.054	45.549	46.050	46.556
37	47.067	47.582	48.102	48.627	49.157
38	49.692	50.231	50.774	51.323	51.879
39	52.442	53.009	53.580	54.156	54.737
40	55.324	55.910	56.510	57.110	57.720
41	58.340	58.960	59.580	60.220	60.860
42	61.500	62.140	62.800	63.460	64.120
43	64.800	65.480	66.160	66.860	67.560
44	68.260	68.970	69.690	70.410	71.140
45	71.880	72.620	73.360	74.120	74.880
46	75.650	76.430	77.210	78.000	78.800
47	79.600	80.410	81.230	82.050	82.870
48	83.710	84.560	85.420	86.280	87.140
49	88.020	88.900	89.790	90.690	91.590

Table A-1: Vapor Pressure of Water (cont.)

Aqueous Vapor Pressure Over Water (cont.)					
Temp. (°C)	0.0	0.2	0.4	0.6	0.8
50	92.51	93.50	94.40	95.30	96.30
51	97.20	98.20	99.10	100.10	101.10
52	102.09	103.10	104.10	105.10	106.20
53	107.20	108.20	109.30	110.40	111.40
54	112.51	113.60	114.70	115.80	116.90
55	118.04	119.10	120.30	121.50	122.60
56	123.80	125.00	126.20	127.40	128.60
57	129.82	131.00	132.30	133.50	134.70
58	136.08	137.30	138.50	139.90	141.20
59	142.60	143.90	145.20	146.60	148.00
60	149.38	150.70	152.10	153.50	155.00
61	156.43	157.80	159.30	160.80	162.30
62	163.77	165.20	166.80	168.30	169.80
63	171.38	172.90	174.50	176.10	177.70
64	179.31	180.90	182.50	184.20	185.80
65	187.54	189.20	190.90	192.60	194.30
66	196.09	197.80	199.50	201.30	203.10
67	204.96	206.80	208.60	210.50	212.30
68	214.17	216.00	218.00	219.90	221.80
69	223.73	225.70	227.70	229.70	231.70
70	233.70	235.70	237.70	239.70	241.80
71	243.90	246.00	248.20	250.30	252.40
72	254.60	256.80	259.00	261.20	263.40
73	265.70	268.00	270.20	272.60	274.80
74	277.20	279.40	281.80	284.20	286.60

Table A-1: Vapor Pressure of Water (cont.)

Aqueous Vapor Pressure Over Water (cont.)					
Temp. (°C)	0.0	0.2	0.4	0.6	0.8
75	289.10	291.50	294.00	296.40	298.80
76	301.40	303.80	306.40	308.90	311.40
77	314.10	316.60	319.20	322.00	324.60
78	327.30	330.00	332.80	335.60	338.20
79	341.00	343.80	346.60	349.40	352.20
80	355.10	358.00	361.00	363.80	366.80
81	369.70	372.60	375.60	378.80	381.80
82	384.90	388.00	391.20	394.40	397.40
83	400.60	403.80	407.00	410.20	413.60
84	416.80	420.20	423.60	426.80	430.20
85	433.60	437.00	440.40	444.00	447.50
86	450.90	454.40	458.00	461.60	465.20
87	468.70	472.40	476.00	479.80	483.40
88	487.10	491.00	494.70	498.50	502.20
89	506.10	510.00	513.90	517.80	521.80
90	525.76	529.77	533.80	537.86	541.95
91	546.05	550.18	554.35	558.53	562.75
92	566.99	571.26	575.55	579.87	584.22
93	588.60	593.00	597.43	601.89	606.38
94	610.90	615.44	620.01	624.61	629.24
95	633.90	638.59	643.30	648.05	652.82
96	657.62	662.45	667.31	672.20	677.12
97	682.07	687.04	692.05	697.10	702.17
98	707.27	712.40	717.56	722.75	727.98
99	733.24	738.53	743.85	749.20	754.58
100	760.00	765.45	770.93	776.44	782.00
101	787.57	793.18	798.82	804.50	810.21

Table A-2: Maximum Gas Flow Rates

Based on the physical characteristics of air at a temperature of 77°F and a pressure of 1 atm, the following flow rates will produce the maximum allowable gas stream linear velocity of 10,000 cm/sec in the corresponding pipe sizes.

Inside Pipe Diameter (in.)	Gas Flow Rate (cfm)
0.25	7
0.50	27
0.75	60
1.0	107
2.0	429
3.0	966
4.0	1,718
5.0	2,684
6.0	3,865
7.0	5,261
8.0	6,871
9.0	8,697
10.0	10,737
11.0	12,991
12.0	15,461

Table A-3: Maximum Liquid Flow Rates

Based on the physical characteristics of benzene at a temperature of 77°F, the following flow rates will produce the maximum allowable fluid linear velocity of 10 cm/sec in the corresponding pipe sizes.

Inside Pipe Diameter (in.)	Flow Rate (gal/hr)	Flow Rate (l/hr)
0.25	3	11
0.50	12	46
0.75	27	103
1.0	48	182
2.0	193	730
3.0	434	1,642
4.0	771	2,919
5.0	1,205	4,561
6.0	1,735	6,567
7.0	2,361	8,939
8.0	3,084	11,675
9.0	3,903	14,776
10.0	4,819	18,243
11.0	5,831	22,074
12.0	6,939	26,269

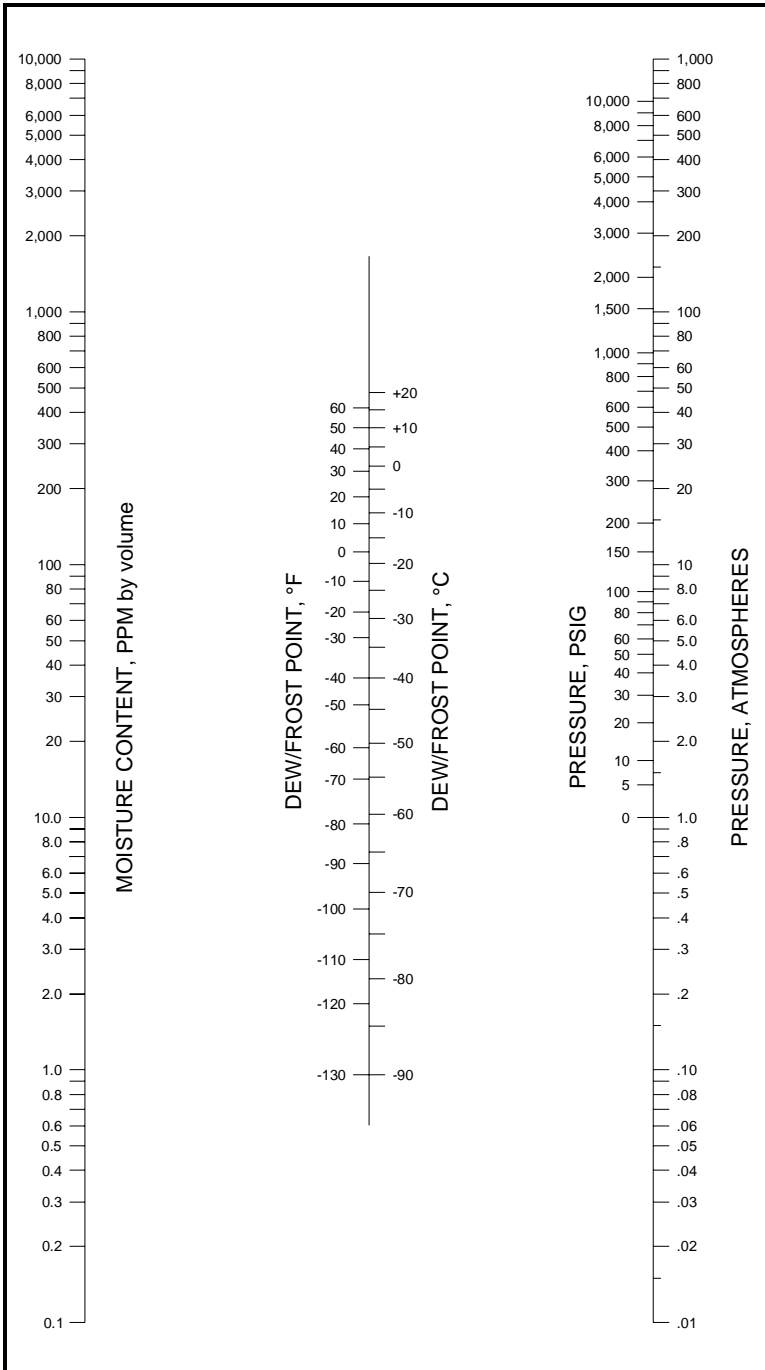

Figure A-1: Moisture Content Nomograph for Gases

Comparison of PPM_v Calculations

There are three basic methods for determining the moisture content of a gas in PPM_v:

- the calculations described in this appendix
- calculations performed with the slide rule device that is provided with each GE Panametrics hygrometer
- values determined from tabulated vapor pressures

For comparison purposes, examples of all three procedures are listed in Table A-4.

Table A-4: Comparative PPM_v Values

Dew Point (°C)	Pressure (psig)	Calculation Method		
		Slide Rule	Appendix A	Vapor Pressure
-80	0	0.5	0.55	0.526
	100	0.065	N.A.	0.0675
	800	0.009	N.A.	0.0095
	1500	0.005	N.A.	0.0051
-50	0	37	40	38.88
	100	4.8	5.2	4.98
	800	0.65	0.8	0.7016
	1500	0.36	0.35	0.3773
+20	0	N.A.	20,000	23,072.36
	100	3000	3000	2956.9
	800	420	400	416.3105
	1500	220	200	223.9

Liquid Applications

Theory of Operation

The direct measurement of water vapor pressure in organic liquids is accomplished easily and effectively with GE Panametrics' Aluminum Oxide Moisture Sensors. Since the moisture probe pore openings are small in relation to the size of most organic molecules, admission into the sensor cavity is limited to much smaller molecules, such as water. Thus, the surface of the aluminum oxide sensor, which acts as a semi-permeable membrane, permits the measurement of water vapor pressure in organic liquids just as easily as it does in gaseous media.

In fact, an accurate sensor electrical output will be registered whether the sensor is directly immersed in the organic liquid or it is placed in the gas space above the liquid surface. As with gases, the electrical output of the aluminum oxide sensor is a function of the measured water vapor pressure.

Moisture Content Measurement in Organic Liquids

Henry's Law Type Analysis

When using the aluminum oxide sensor in non-polar liquids having water concentrations $\leq 1\%$ by weight, *Henry's Law* is generally applicable. Henry's Law states that, at constant temperature, *the mass of a gas dissolved in a given volume of liquid is proportional to the partial pressure of the gas in the system*. Stated in terms pertinent to this discussion, it can be said that the PPM_W of water in hydrocarbon liquids is equal to the partial pressure of water vapor in the system times a constant.

As discussed above, a GE Panametrics aluminum oxide sensor can be directly immersed in a hydrocarbon liquid to measure the equivalent dew point. Since the dew point is functionally related to the vapor pressure of the water, a determination of the dew point will allow one to calculate the PPM_W of water in the liquid by a Henry's Law type analysis. A specific example of such an analysis is shown below.

Henry's Law Type Analysis (cont.)

For liquids in which a Henry's Law type analysis is applicable, the parts per million by weight of water in the organic liquid is equal to the partial pressure of water vapor times a constant:

$$\text{PPM}_W = K \times P_W \quad (\text{a})$$

where, K is the Henry's Law constant in the appropriate units, and the other variables are as defined on page A-13.

Also, the value of K is determined from the known water saturation concentration of the organic liquid at the measurement temperature:

$$K = \frac{\text{Saturation PPM}_W}{P_S} \quad (\text{b})$$

For a mixture of organic liquids, an average saturation value can be calculated from the weight fractions and saturation values of the pure components as follows:

$$\text{Ave. } C_S = \sum_{i=1}^n X_i (C_S)_i \quad (\text{c})$$

where, X_i is the weight fraction of the i^{th} component, $(C_S)_i$ is the saturation concentration (PPM_W) of the i^{th} component, and n is the total number of components.

In conclusion, the Henry's Law constant (K) is a constant of proportionality between the saturation concentration (C_S) and the saturation vapor pressure (P_S) of water, at the measurement temperature. In the *General Case*, the Henry's Law constant varies with the measurement temperature, but there is a *Special Case* in which the Henry's Law constant does not vary appreciably with the measurement temperature. This special case applies to saturated, straight-chain hydrocarbons such as pentane, hexane, heptane, etc.

A: General Case

Determination of Moisture Content if C_S is Known:

The nomograph for liquids in Figure A-2 can be used to determine the moisture content in an organic liquid, if the following values are known:

- the temperature of the liquid at the time of measurement
- the saturation water concentration at the measurement temperature
- the dew point, as measured with the GE Panametrics hygrometer

Complete the following steps to determine the moisture content from the nomograph:

1. Using a straightedge on the two scales on the right of the figure, connect the known saturation concentration (PPM_W) with the measurement temperature ($^{\circ}\text{C}$).
2. Read the Henry's Law constant (K) on the center scale.
3. Using a straightedge, connect above K value with the dew/frost point, as measured with the GE Panametrics' hygrometer.
4. Read the moisture content (PPM_W) where the straight edge crosses the moisture content scale.

Empirical Determination of K and C_S

If the values of K and C_S are not known, the GE Panametrics hygrometer can be used to determine these values. In fact, only one of the values is required to determine PPM_W from the nomograph in Figure A-2. To perform such an analysis, proceed as follows:

1. Obtain a sample of the test solution with a known water content; or perform a *Karl Fischer* titration on a sample of the test stream to determine the PPM_W of water.

Empirical Determination of K and C_S (cont.)

Note: *The Karl Fischer analysis involves titrating the test sample against a special Karl Fischer reagent until an endpoint is reached.*

2. Measure the dew point of the known sample with the GE Panametrics hygrometer.
3. Measure the temperature (°C) of the test solution.
4. Using a straightedge, connect the moisture content (PPM_W) with the measured dew point, and read the K value on the center scale.
5. Using a straightedge, connect the above K value with the measured temperature (°C) of the test solution, and read the saturation concentration (PPM_W).

Note: *Since the values of K and C_S vary with temperature, the hygrometer measurement and the test sample analysis must be done at the same temperature. If the moisture probe temperature is expected to vary, the test should be performed at more than one temperature.*

B: SPECIAL CASE

As mentioned earlier, saturated straight-chain hydrocarbons represent a special case, where the Henry's Law constant does not vary appreciably with temperature. In such cases, use the nomograph for liquids in Figure A-2 to complete the analysis.

Determination of moisture content if the Henry's Law constant (K) is known.

1. Using a straightedge, connect the known K value on the center scale with the dew/frost point, as measured with the GE Panametrics hygrometer.
2. Read moisture content (PPM_W) where the straightedge crosses the scale on the left.

B: SPECIAL CASE (cont.)*Typical Problems*

1. Find the moisture content in benzene, at an ambient temperature of 30°C, if a dew point of 0°C is measured with the GE Panametrics hygrometer.
 - a. From the literature, it is found that C_S for benzene at a temperature of 30°C is **870 PPM_W**.
 - b. Using a straightedge on Figure A-2, connect the 870 PPM_W saturation concentration with the 30°C ambient temperature and read the Henry's Law Constant of **27.4** on the center scale.
 - c. Using the straightedge, connect the above K value of 27.4 with the measured dew point of 0°C, and read the correct moisture content of **125 PPM_W** where the straightedge crosses the moisture content scale.

2. Find the moisture content in heptane, at an ambient temperature of 50°C, if a dew point of 3°C is measured with the GE Panametrics hygrometer.
 - a. From the literature, it is found that C_S for heptane at a temperature of 50°C is **480 PPM_W**.
 - b. Using a straightedge on Figure A-2, connect the 480 PPM_W saturation concentration with the 50°C ambient temperature and read the Henry's Law Constant of **5.2** on the center scale.
 - c. Using the straightedge, connect the above K value of 5.2 with the measured dew point of 3°C, and read the correct moisture content of **29 PPM_W** where the straightedge crosses the moisture content scale.

B: SPECIAL CASE (cont.)

Note: *If the saturation concentration at the desired ambient temperature can not be found for any of these special case hydrocarbons, the value at any other temperature may be used, because K is constant over a large temperature range.*

3. Find the moisture content in hexane, at an ambient temperature of 10°C, if a dew point of 0°C is measured with the GE Panametrics hygrometer.
 - a. From the literature, it is found that C_S for hexane at a temperature of 20°C is **101 PPM_W**.
 - b. Using a straightedge on Figure A-2, connect the 101 PPM_W saturation concentration with the 20°C ambient temperature and read the Henry's Law Constant of **5.75** on the center scale.
 - c. Using the straightedge, connect the above K value of 5.75 with the measured dew point of 0°C, and read the correct moisture content of **26 PPM_W** where the straightedge crosses the moisture content scale.
4. Find the moisture content in an unknown organic liquid, at an ambient temperature of 50°C, if a dew point of 10°C is measured with the GE Panametrics hygrometer.
 - a. Either perform a Karl Fischer analysis on a sample of the liquid or obtain a dry sample of the liquid.
 - b. Either use the PPM_W determined by the Karl Fischer analysis or add a known amount of water (i.e. 10 PPM_W) to the dry sample.

B: SPECIAL CASE (cont.)

- c. Measure the dew point of the known test sample with the GE Panametrics hygrometer. For purposes of this example, assume the measured dew point to be -10°C .
- d. Using a straightedge on the nomograph in Figure A-2, connect the known $10 \text{ PPM}_{\text{W}}$ moisture content with the measured dew point of -10°C , and read a K value of **5.1** on the center scale.
- e. Using the straightedge, connect the above K value of 5.1 with the measured 10°C dew point of the original liquid, and read the actual moisture content of **47 PPM_W** on the left scale.

Note: *The saturation value at 50°C for this liquid could also have been determined by connecting the K value of 5.1 with the ambient temperature of 50°C and reading a value of 475 PPM_W on the right scale.*

For many applications, a knowledge of the absolute moisture content of the liquid is not required. Either the dew point of the liquid or its percent saturation is the only value needed. For such applications, the saturation value for the liquid need not be known. The GE Panametrics hygrometer can be used directly to determine the dew point, and then the percent saturation can be calculated from the vapor pressures of water at the measured dew point and at the ambient temperature of the liquid:

$$\% \text{ Saturation} = \frac{C}{C_S} \times 100 = \frac{P_W}{P_S} \times 100$$

Empirical Calibrations

For those liquids in which a Henry's Law type analysis is not applicable, the absolute moisture content is best determined by empirical calibration. A Henry's Law type analysis is generally not applicable for the following classes of liquids:

- liquids with a high saturation value (2% by weight of water or greater)
- liquids, such as dioxane, that are completely miscible with water
- liquids, such as isopropyl alcohol, that are conductive

For such liquids, measurements of the hygrometer dew point readings for solutions of various known water concentrations must be performed. Such a calibration can be conducted in either of two ways:

- perform a Karl Fischer analysis on several unknown test samples of different water content
- prepare a series of known test samples via the addition of water to a quantity of dry liquid

In the latter case, it is important to be sure that the solutions have reached equilibrium before proceeding with the dew point measurements.

Note: *Karl Fisher analysis is a method for measuring trace quantities of water by titrating the test sample against a special Karl Fischer reagent until a color change from yellow to brown (or a change in potential) indicates that the end point has been reached.*

Either of the empirical calibration techniques described above can be conducted using an apparatus equivalent to that shown in Figure A-3. The apparatus pictured can be used for both the Karl Fischer titrations of unknown test samples and the preparation of test samples with known moisture content. Procedures for both of these techniques are presented below.

A. Instructions for Karl Fischer Analysis

To perform a Karl Fisher analysis, use the apparatus in Figure A-3 and complete the following steps:

1. Fill the glass bottle completely with the sample liquid.
2. Close both valves and turn on the magnetic stirrer.
3. Permit sufficient time for the entire test apparatus and the sample liquid to reach equilibrium with the ambient temperature.
4. Turn on the hygrometer and monitor the dew point reading. When a stable dew point reading indicates that equilibrium has been reached, record the reading.
5. Insert a syringe through the rubber septum and withdraw a fluid sample for Karl Fischer analysis. Record the actual moisture content of the sample.
6. Open the exhaust valve.
7. Open the inlet valve and increase the moisture content of the sample by bubbling wet N_2 through the liquid (or decrease the moisture content by bubbling dry N_2 through the liquid).
8. When the hygrometer reading indicates the approximate moisture content expected, close both valves.
9. Repeat steps 3-8 until samples with several different moisture contents have been analyzed.

B. Instructions for Preparing Known Samples

Note: *This procedure is only for liquids that are highly miscible with water. Excessive equilibrium times would be required with less miscible liquids.*

To prepare samples of known moisture content, use the apparatus in Figure A-3 and complete the following steps:

1. Weigh the dry, empty apparatus.
2. Fill the glass bottle with the sample liquid.
3. Open both valves and turn on the magnetic stirrer.
4. While monitoring the dew point reading with the hygrometer, bubble dry N₂ through the liquid until the dew point stabilizes at some minimum value.
5. Turn off the N₂ supply and close both valves.
6. Weigh the apparatus, including the liquid, and calculate the sample weight by subtracting the step 1 weight from this weight.
7. Insert a syringe through the rubber septum and add a known weight of H₂O to the sample. Continue stirring until the water is completely dissolved in the liquid.
8. Record the dew point indicated by the hygrometer and calculate the moisture content as follows:

$$\text{PPM}_W = \frac{\text{weight of water}}{\text{total weight of liquid}} \times 10^6$$

9. Repeat steps 6-8 until samples with several different moisture contents have been analyzed.

Note: *The accuracy of this technique can be checked at any point by withdrawing a sample and performing a Karl Fischer titration. Be aware that this will change the total liquid weight in calculating the next point.*

C. Additional Notes for Liquid Applications

In addition to the topics already discussed, the following general application notes pertain to the use of GE Panametrics moisture probes in liquid applications:

1. All M Series Aluminum Oxide Moisture Sensors can be used in either the gas phase or the liquid phase. However, for the detection of trace amounts of water in conductive liquids (for which an empirical calibration is required), the M2 Sensor is recommended. Since a background signal is caused by the conductivity of the liquid between the sensor lead wires, use of the M2 Sensor (which has the shortest lead wires) will result in the best sensitivity.
2. The calibration data supplied with GE Panametrics Moisture Probes is applicable to both liquid phase (for those liquids in which a Henry's Law analysis is applicable) and gas phase applications.
3. As indicated in Table A-3, the flow rate of the liquid is limited to a maximum of 10 cm/sec.
4. Possible probe malfunctions and their remedies are discussed in the *Troubleshooting* chapter of this manual.

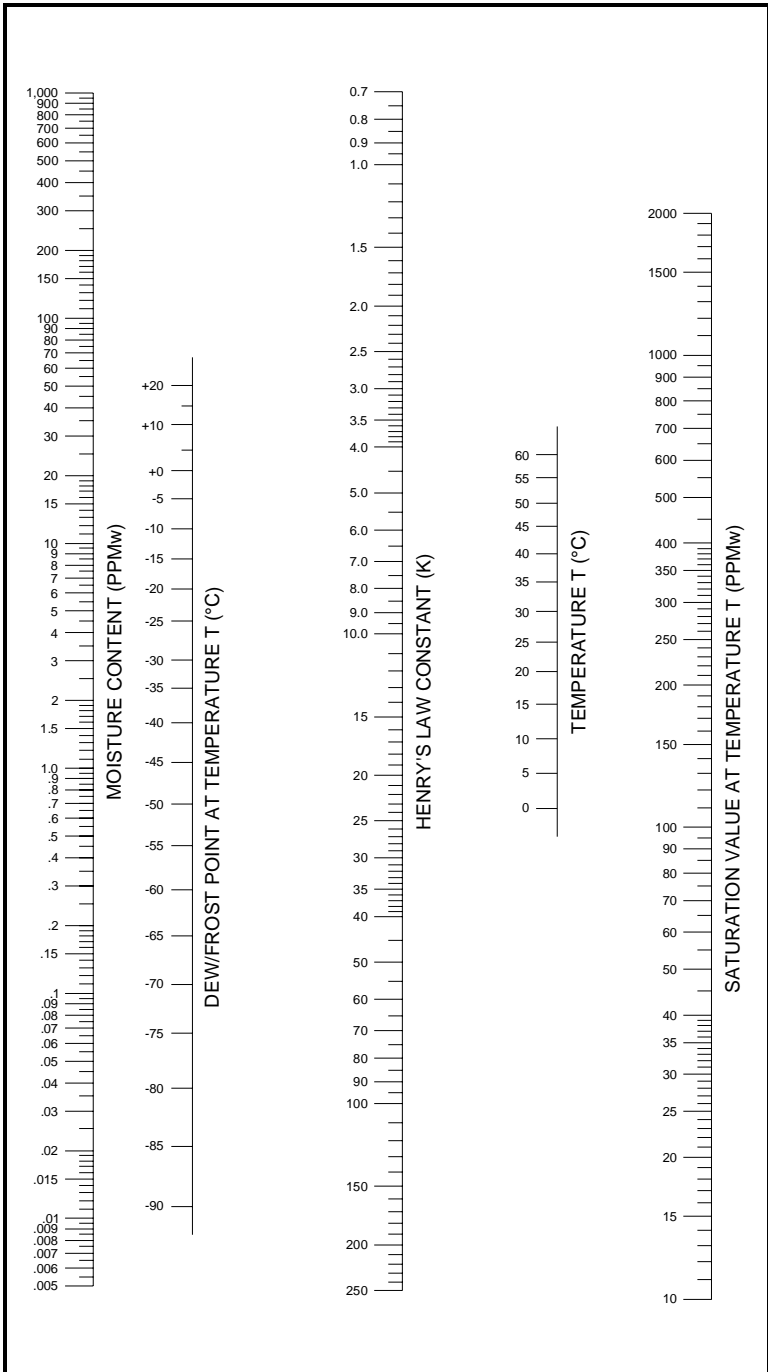

Figure A-2: Moisture Content Nomograph for Liquids

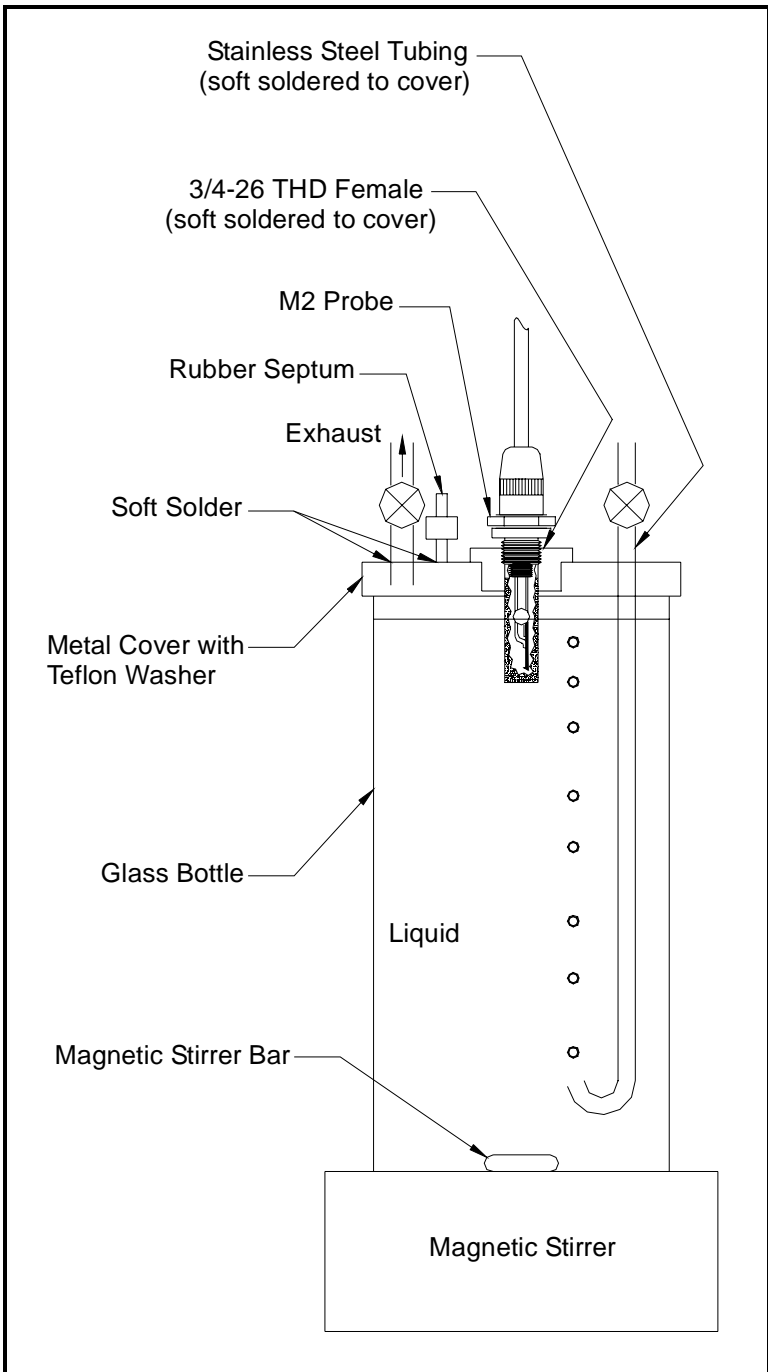

Figure A-3: Moisture Content Test Apparatus

Solids Applications

A. In-Line Measurements

GE Panametrics moisture probes may be installed in-line to continuously monitor the drying process of a solid. Install one sensor at the process system inlet to monitor the moisture content of the drying gas and install a second sensor at the process system outlet to monitor the moisture content of the discharged gas. When the two sensors read the same (or close to the same) dew point, the drying process is complete. For example, a system of this type has been used successfully to monitor the drying of photographic film.

If one wishes to measure the absolute moisture content of the solid at any time during such a process, then an empirical calibration is required:

1. At a particular set of operating conditions (i.e. flow rate, temperature and pressure), the hygrometer dew point reading can be calibrated against solids samples with known moisture contents.
2. Assuming the operating conditions are relatively constant, the hygrometer dew point reading can be noted and a solids sample withdrawn for laboratory analysis.
3. Repeat this procedure until a calibration curve over the desired moisture content range has been developed.

Once such a curve has been developed, the hygrometer can then be used to continuously monitor the moisture content of the solid (as long as operating conditions are relatively constant).

B. Laboratory Procedures

If in-line measurements are not practical, then there are two possible laboratory procedures:

1. The unique ability of the GE Panametrics sensor to determine the moisture content of a liquid can be used as follows:
 - a. Using the apparatus shown in Figure A-3, dissolve a known amount of the solids sample in a suitable hydrocarbon liquid.
 - b. The measured increase in the moisture content of the hydrocarbon liquid can then be used to calculate the moisture content of the sample.

For best results, the hydrocarbon liquid used above should be pre-dried to a moisture content that is insignificant compared to the moisture content of the sample.

Note: *Since the addition of the solid may significantly change the saturation value for the solvent, published values should not be used. Instead, an empirical calibration, as discussed in the previous section, should be used.*

A dew point of -110°C , which can correspond to a moisture content of 10^{-6} PPM_W or less, represents the lower limit of sensor sensitivity. The maximum measurable moisture content depends to a great extent on the liquid itself. Generally, the sensor becomes insensitive to moisture contents in excess of 1% by weight.

B. Laboratory Procedures (cont.)

2. An alternative technique involves driving the moisture from the solids sample by heating:
 - a. The evaporated moisture is directed into a chamber of known volume, which contains a calibrated moisture sensor.
 - b. Convert the measured dew point of the chamber into a water vapor pressure, as discussed earlier in this appendix. From the known volume of the chamber and the measured vapor pressure (dew point) of the water, the number of moles of water in the chamber can be calculated and related to the percent by weight of water in the test sample.

Although this technique is somewhat tedious, it can be used successfully. An empirical calibration of the procedure may be performed by using hydrated solids of known moisture content for test samples.

Appendix B

Outline and Installation Drawings

This appendix contains the following outline and installation drawings:

- MMS35 IS with Sample System (712-940A)
- MMS35 IS without Sample System (712-940B)
- Internal Sample System Assembly (750-297)
- RS232 Cable Assembly (704-693)

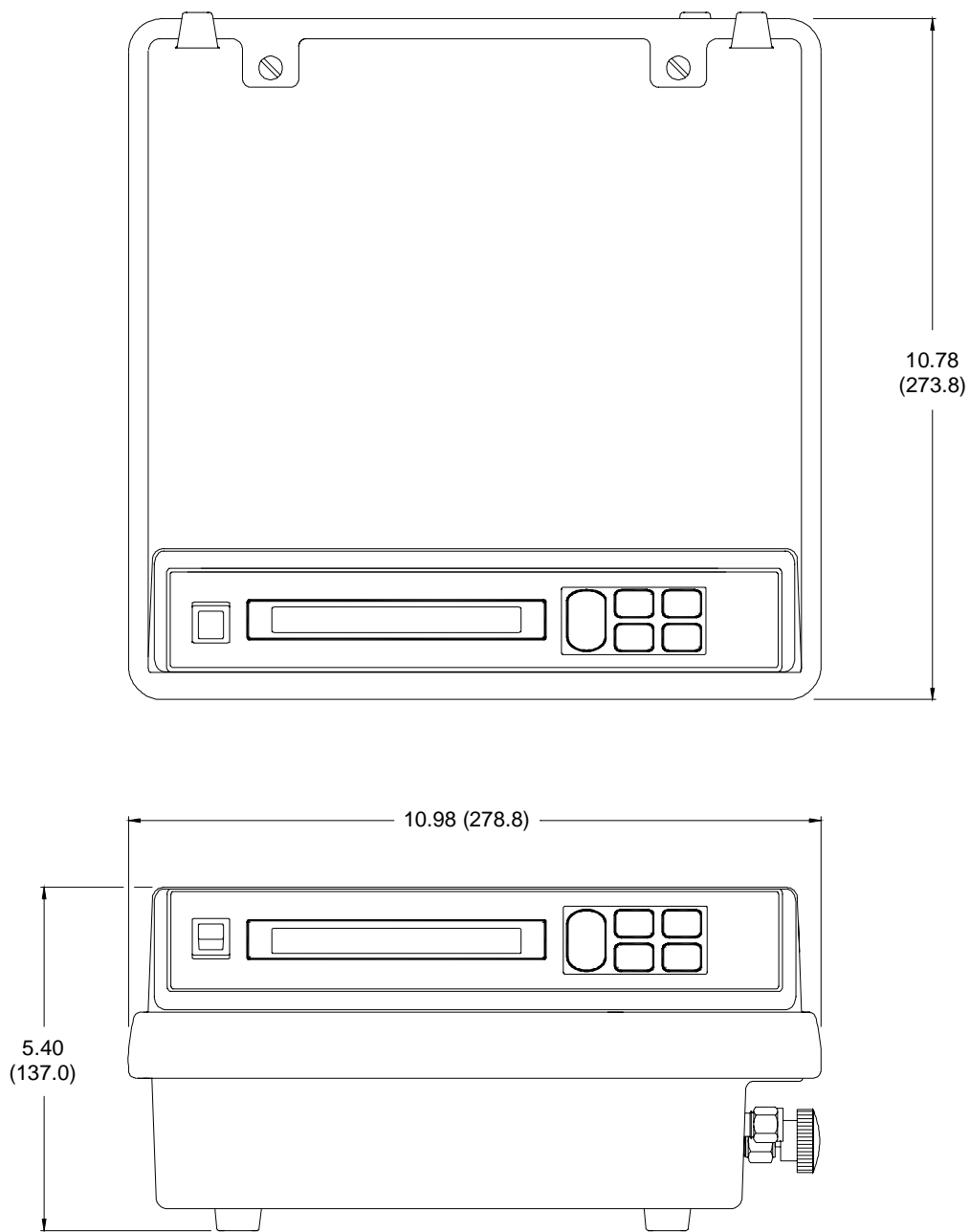

Figure B-1: MMS35 IS with Sample System)

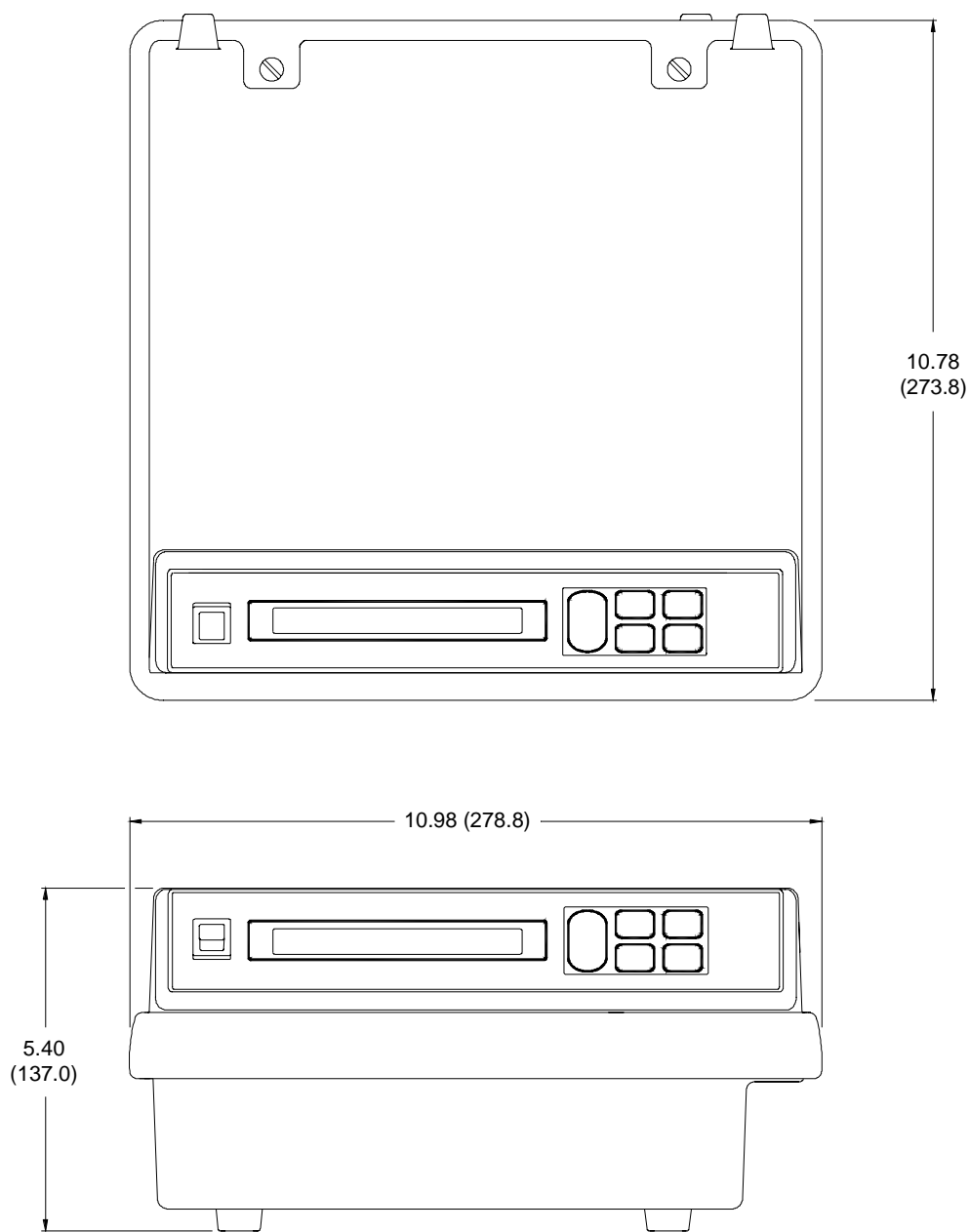
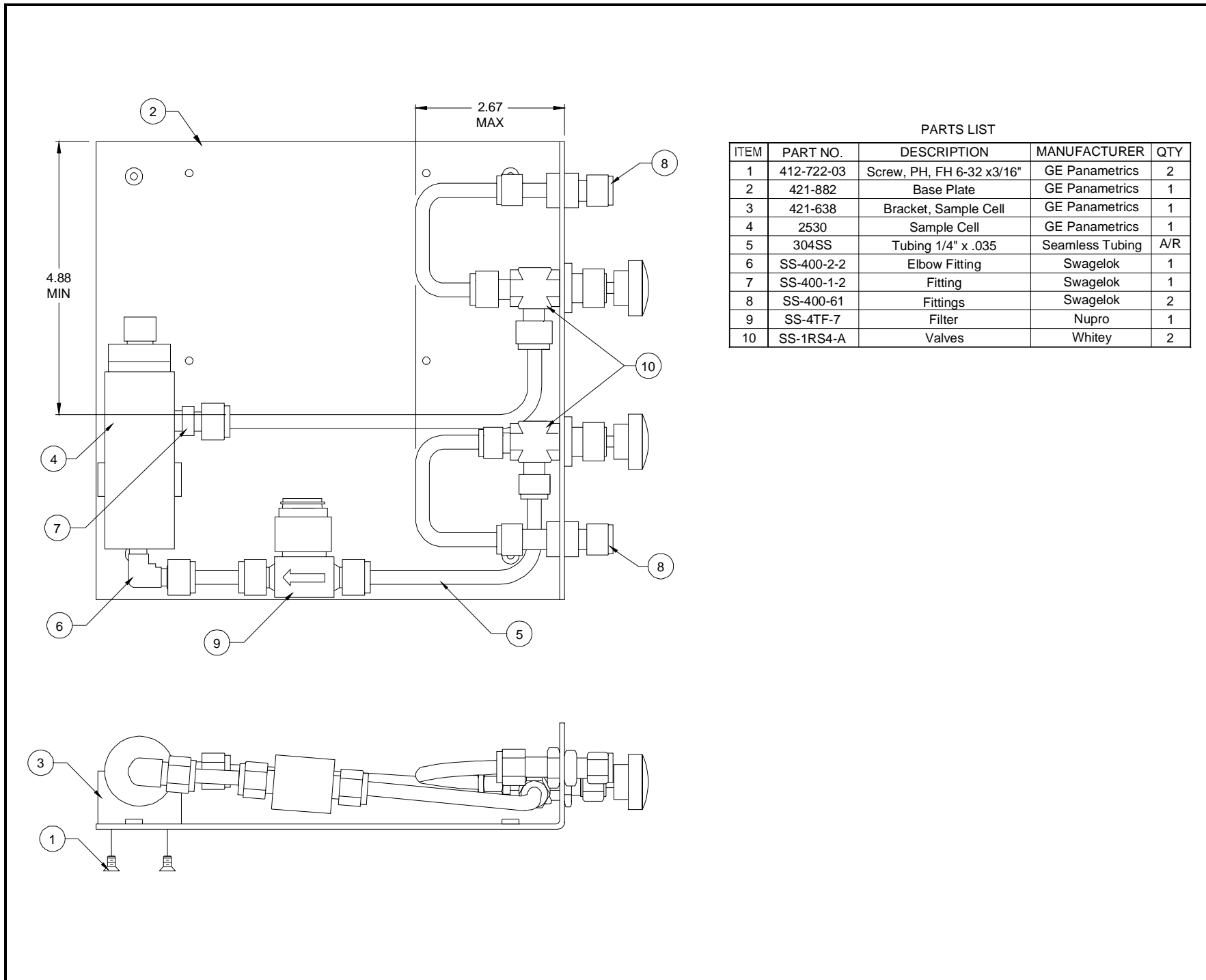

Figure B-2: MMS35 IS without Sample System



PARTS LIST

ITEM	PART NO.	DESCRIPTION	MANUFACTURER	QTY
1	412-722-03	Screw, PH, FH 6-32 x3/16"	GE Panametrics	2
2	421-882	Base Plate	GE Panametrics	1
3	421-638	Bracket, Sample Cell	GE Panametrics	1
4	2530	Sample Cell	GE Panametrics	1
5	304SS	Tubing 1/4" x .035	Seamless Tubing	A/R
6	SS-400-2-2	Elbow Fitting	Swagelok	1
7	SS-400-1-2	Fitting	Swagelok	1
8	SS-400-61	Fittings	Swagelok	2
9	SS-4TF-7	Filter	Nupro	1
10	SS-1RS4-A	Valves	Whitey	2

Figure B-3: Internal Sample System Assembly

Figure B-4: RS232 Cable Assembly

TABLE 1 CONFIGURATION		
DASH NO.	PC END CONN. PINS	LENGTH, L FT.
-02	9	5
-03	9	10
-04	9	15
-05	9	20
-12	25	5
-13	25	10
-14	25	15
-15	25	20

TABLE 2 WIRE RUN LIST				
PART NO.	CONN (MMS35IS END)		CONNS (PC END)	
	PIN NO.	WIRE COLOR	PIN NO.	WIRE COLOR
704-556-02	2	RED	3	RED
THRU	3	GRN	2	GRN
704-556-05	5	BLK/DRAIN	5	BLK
704-556-12	2	RED	2	RED
THRU	3	GRN	3	GRN
704-556-15	5	BLK/DRAIN	7	BLK

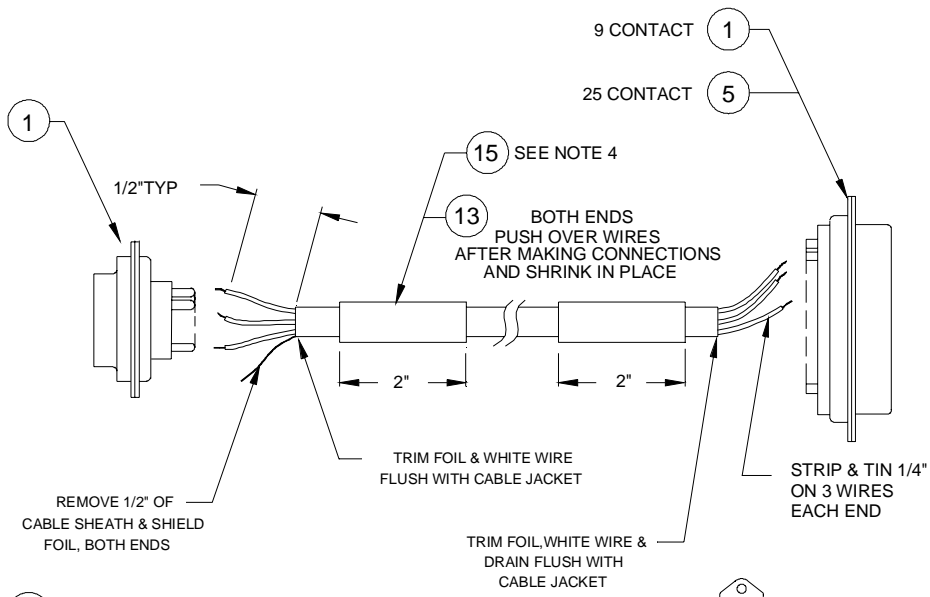
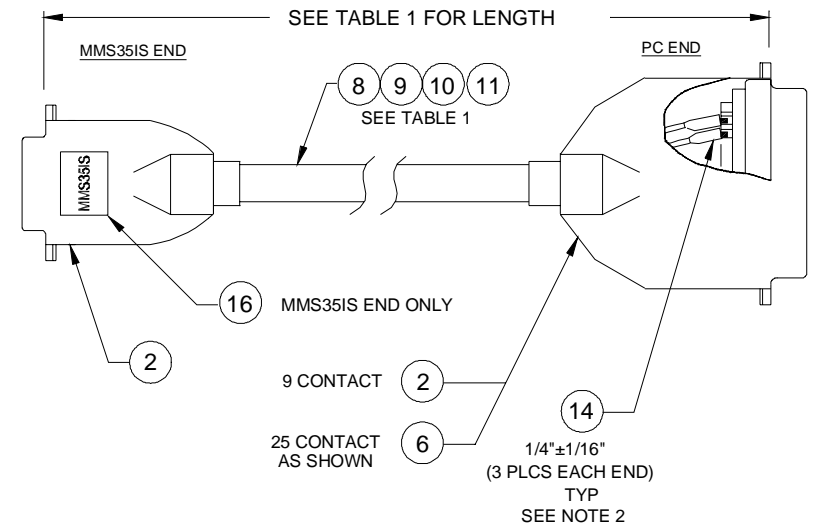

NOTES:

1. NO BROKEN OR NICKED STRANDS PERMITTED (TIN ALL LEADS).
2. SHRINK ITEM 14 ON EACH CONTACT AFTER SOLDERING WIRE TO CONTACT.
3. TOLERANCE: SLEEVING ± 1/4" LENGTH ± 6"
4. AFTER SHRINKING SLEEVING (ITEM 13) IN PLACE, POSITION AND SHRINK THE OTHER SLEEVE (ITEM 15) OVER THE FIRST SLEEVE IN ORDER TO PROVIDE ADEQUATE STRAIN RELIEF WHEN CONNECTOR IS CLOSED UP.

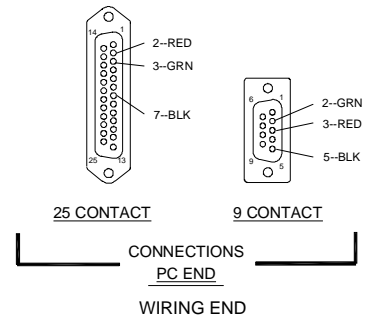
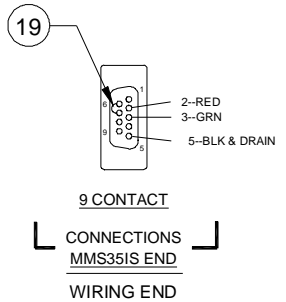

Appendix C

Menu Map

Figure C-1 is a top-level diagram of the Series 35 IS menu. Once you are familiar with how the Series 35 IS operates, use this diagram as a reference for moving through the user program.

To enter the programming mode, perform the following sequence within five (5) seconds, or the Series 35 IS will time out and return to the measurement mode.

P: +0.00 Kcmg	While in run mode, press the [ESC] key.
ESC	Within 5 seconds of the appearance of this display, press the [ENTER] key followed by the [ESC] key.
PROGRAM MENU	This will display for 1 second.
DP RANGE	You are now in the user program menu.

From the main menu, use the arrow keys to scroll through the options to your selection. Use the [ENTER] key to confirm your selection or the [ESC] key to cancel your selection.

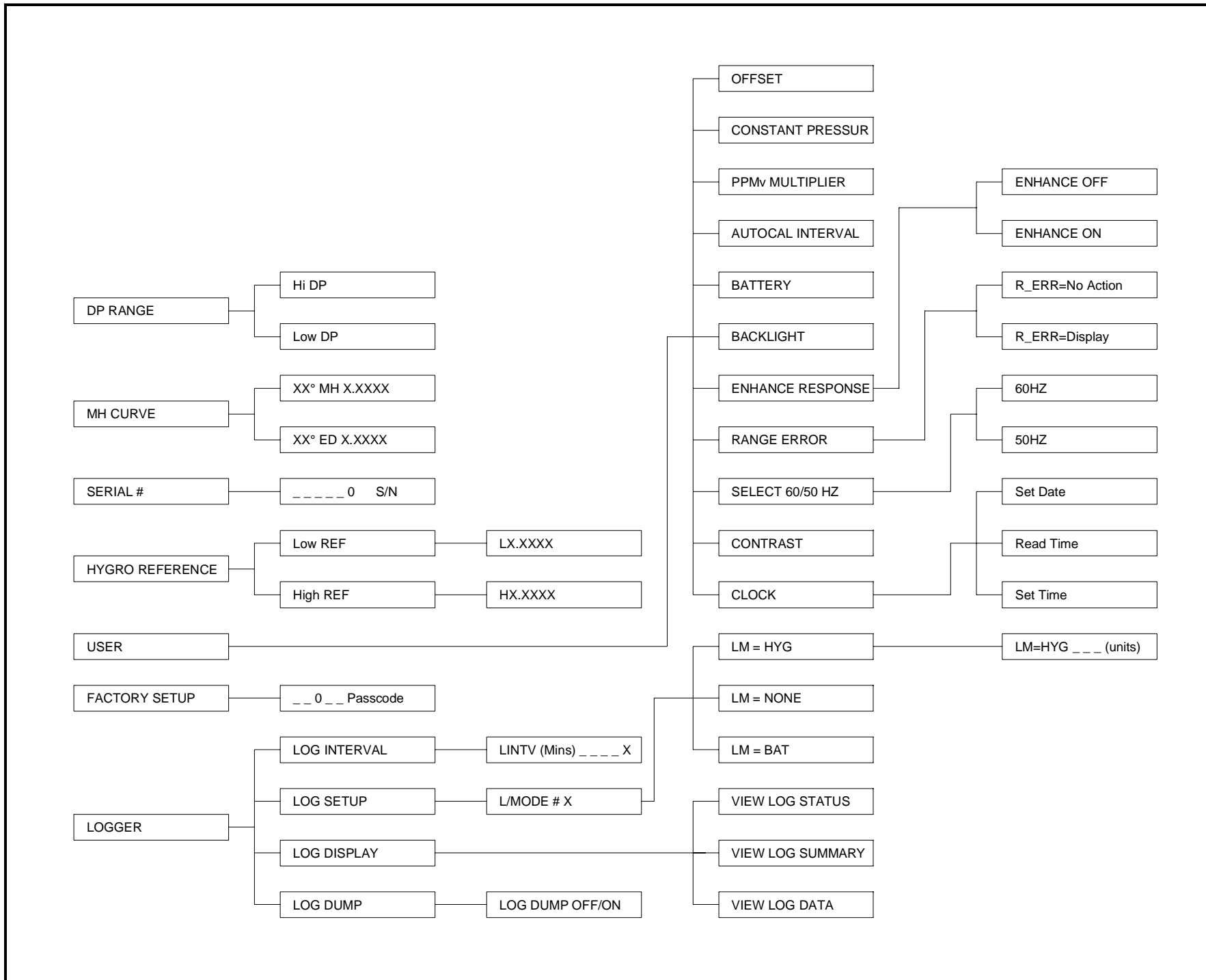

Figure C-1: Moisture Monitor Series 35 IS Menu Map

Appendix D

Data Information Sheet

Use this sheet to record all of the data that you enter into the user program. If data is lost for any reason, use this sheet to re-program your unit. Store this sheet and any other related documents in a safe place for future reference.

Tables are provided for entry of the following information:

- Dew Point Measurement Range [page D-2]
- Calibration Data for Moisture [page D-2]
- Serial Number [page D-3]
- MH Reference Values for Moisture [page D-3]
- User Defined Functions [page D-3]
- Logger [page D-4]

Series 35 IS Data Information Sheet

Notes:

Date: _____

Unit Serial Number: _____

Application Description: _____

Table D-1: Dew Point Measurement Range

High	Low

Table D-2: Calibration Data for Moisture

Point #	MH Value
1	
2	
3	
4	
5	
6	
7	
8	
9	
10	
11	
12	
13	
14	

Series 35 IS Data Information Sheet (cont.)

Table D-3: Serial Number

<p>— — — — —</p>

Table D-4: MH Reference Values for Moisture

High	Low

Table D-5: User-Defined Functions

Function	Setting
Offset Value	
Constant Pressure	
PPMv Constant Multiplier	
Autocal Interval	
Battery	
Backlight-On Time Interval	
Computer-Enhanced Response	
Range Error Handling	
Selecting 60/50 Hz	

Series 35 IS Data Information Sheet (cont.)

Table D-6: Logger

Function	Setting	
Log Interval	LINTV (Mins): _____	+
Log Setup	L/Mode #1:	HYG NONE BAT (units = _____)
	L/Mode #2:	HYG NONE BAT (units = _____)
	L/Mode #3:	HYG NONE BAT (units = _____)
Log Display	View Log Status	_____
	View Log Summary	_____
	View Log Data	_____
Log Dump	OFF _____	ON _____

Appendix E

Series 35 IS Hygrometer Spare Parts List

Spare parts for the portable Moisture Monitor Series 35 IS are available directly from GE Panametrics. Table E-1 below lists the ordering information for the most commonly needed spare parts. If you require parts that are not listed in Table E-1, contact GE Panametrics for assistance.

Table E-1: Spare Parts List

P/N	Qty*	Description
705-799	1	Display Assembly
200-050	1	Battery Pack
M2L	1	Moisture Probe
201-055	1	120V Battery Charger
201-066	1	240V Battery Charger
076	1**	7-micron Sintered SS Filter Elements (pkg. of 4)
* recommended for 0-2 years operation		
**required only for unit with internal sample system		

Index

A

AC Line Frequency	3-26
Applications	
Gases	A-13
Liquids	A-27
Solids	A-40
Automatic Calibration	3-19

B

Backlight-On	3-22
Battery Charger	4-8
Battery Status	3-21
Battery, Recharging and Replacing	4-8

C

Cables, Modified	2-14
Calculations	A-13
Calibration	
Adjustment	2-15
Empirical	A-34
Reference Sticker	2-15
Calibration Data	
Data Sheet	3-12
Entering	3-11
Probe Serial Number	3-12
Circuit Board	
Cable Connections	4-14
Removing	4-14
Replacing	4-19
Clock Values	3-28
Computer-Enhanced Response	3-23
Constant Multiplier	3-18
Constant Pressure Value	3-16
Contaminants	A-7
Contrast Adjustment	3-27
Corrosive Substances	A-8

Index (cont.)

D

Data Information Sheet	D-1
Data Logger	3-30
Parameter(s) to Log	3-32
Viewing Log Data	3-32
Viewing Log Status	3-34
Viewing Log Summary	3-35
Dew Point Range	3-10
Drawings	B-1

E

Electronics Unit	1-2
Empirical Calibrations	A-34
EPROM	4-13
Replacing	4-17
Error Processing	4-7

F

Factory Setup Data	3-9
Flow Rates	
Gases	A-23
Liquids	A-24
Monitoring Hints	A-6

G

Gases	
Corrosive	A-8
Flow Rates	A-23
Getting Started	3-2

I

Installation	
Mounting the Sample System	2-6
Probe Wiring	2-12
Wiring Connections	2-12

K

Keypad	3-5
Displaying Measurements	3-14
Entering Numeric Data	3-8
Using	3-5

Index (cont.)

L

Liquids	
Applications	A-27
Corrosive	A-8
Flow Rates	A-24
Logged Data, Dumping	3-41

M

M Series Probes	1-3
Measurement Display	3-14
Menu Map	C-1
Moisture Probe	1-3, 2-3
Cleaning Procedure	A-9
Contaminants	A-7
Corrosive Substances	A-8
Fluid Velocities	2-4
Gas Flow Rates	A-23
Interference	2-4
Liquid Flow Rates	A-24
M Series	2-3
Materials of Construction	A-12
Moisture Condensation	2-3
Monitoring Hints	A-1
Pressure	2-4
Replacing and Recalibrating	4-20
Storage	2-4
Temperature Range	2-3
Monitoring Hints	
Flow Rate	A-6
Moisture	A-1
Pressure	A-4
Response Time	A-5
Temperature	A-5

O

Offset Value	3-15
--------------	------

Index (cont.)

P

Power Switch.....	3-4
Powering Up.....	3-4
PPMv, Calculating.....	A-14
PPMw, Calculating.....	A-15
Pressure	
Constant Value, Entering.....	3-16
Monitoring Hints.....	A-4
Probe.....	2-8
Connections.....	2-11
Description.....	1-3
Installing.....	2-8
Self-Contained.....	2-8
Wiring.....	2-12
Probe Wiring.....	2-12
Problems.....	4-1
Programming Keys.....	3-5

R

Range Error.....	3-25
Reference Values, Entering.....	3-13
Relative Humidity, Calculating.....	A-15
Response Time, Moisture Probe.....	A-5
Return Policy.....	iv
RS232 Interface.....	3-39
Cable.....	3-39
Dumping Logged Data.....	3-41
Settings.....	3-39

Index (cont.)

S

Sample System	1-3, 2-10
Cable length	2-2
External	2-6
Filter	1-3
Mounting	2-6
Pressure Regulator	1-3
Probe Installation	2-10
Self-Contained	2-7
Temperature	2-2
Valves	2-5
Screen Messages	4-5
Sensor	1-3
Serial Number	3-12
Shield	1-3
Shutting Down	3-4
Site Description	2-2
Solids Applications	A-40
Spare Parts	E-1
Specifications	
Electrical	5-2
General	5-3
Moisture Probe	A-12
Starting Up	3-3

T

Temperature, Monitoring	A-5
Terminal Block	2-12
Troubleshooting and Maintenance	4-1
Contaminants	A-7

U

User Program	
Description	1-4
Entering and Exiting	3-6
EPROM	4-13
Navigating	3-7
Replacing	4-13

W

Warranty	iii
Wiring Connections, Description	2-10
Wiring, Probe	2-12

We,

**GE Panametrics
Shannon Industrial Estate
Shannon, Co. Clare
Ireland**

declare under our sole responsibility that the

**Moisture Monitor Series 35IS Portable Analyzer
PM880 Portable Moisture Monitor**

to which this declaration relates, are in conformity with the following standards:

- EN 50014:1997+A1+A2:1999
- EN 50020:1994
- EN50284:1999
- II 1 G EEx ia IIC T4

PM880: BASEEFA02ATEX0191

Baseefa (2001) Ltd/EECS, Buxton SK17 9JN, UK

MMS 35IS: ISSeP01ATEX035 X; ISSeP, B7340 Colfontaine, Belgium

- EN 61326:1998, Class A, Annex C, Continuous Unmonitored Operation (for EN 61000-4-3, the **MMS 35IS** meets performance Criteria A and, in a limited number of frequencies, performance Criteria B per EN 61326.)

following the provisions of the 89/336/EEC EMC Directive and the 94/9/EC ATEX Directive.

The units listed above and any sensors and ancillary sample handling systems supplied with them do not bear CE marking for the Pressure Equipment Directive, as they are supplied in accordance with Article 3, Section 3 (sound engineering practices and codes of good workmanship) of the Pressure Equipment Directive 97/23/EC for DN<25.

Shannon - July 1, 2003

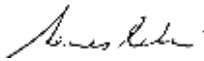

Mr. James Gibson
GENERAL MANAGER



Nous,

**GE Panametrics
Shannon Industrial Estate
Shannon, Co. Clare
Ireland**

déclarons sous notre propre responsabilité que les

**Moisture Monitor Series 35IS Portable Analyzer
PM880 Portable Moisture Monitor**

relatif à cette déclaration, sont en conformité avec les documents suivants:

- EN 50014:1997+A1+A2:1999
- EN 50020:1994
- EN50284:1999
- II 1 G EEx ia IIC T4

PM880: BASEEFA02ATEX0191

Baseefa (2001) Ltd/EECS, Buxton SK17 9JN, UK

MMS 35IS: ISSeP01ATEX035 X; ISSeP, B7340 Colfontaine, Belgium

- EN 61326:1998, Class A, Annex C, Continuous Unmonitored Operation (for EN 61000-4-3, the **MMS 35IS** meets performance Criteria A and, in a limited number of frequencies, performance Criteria B per EN 61326.)

suivant les règles de la Directive de Compatibilité Electromagnétique 89/336/EEC et d'ATEX 94/9/EC.

Les matériels listés ci-dessus, ainsi que les capteurs et les systèmes d'échantillonnages pouvant être livrés avec ne portent pas le marquage CE de la directive des équipements sous pression, car ils sont fournis en accord avec la directive 97/23/EC des équipements sous pression pour les DN<25, Article 3, section 3 qui concerne les pratiques et les codes de bonne fabrication pour l'ingénierie du son.

Shannon - July 1, 2003

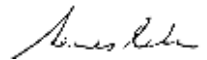

Mr. James Gibson
DIRECTEUR GÉNÉRAL



Wir,

**GE Panametrics
Shannon Industrial Estate
Shannon, Co. Clare
Ireland**

erklären, in alleiniger Verantwortung, daß die Produkte

**Moisture Monitor Series 35IS Portable Analyzer
PM880 Portable Moisture Monitor**

folgende Normen erfüllen:

- EN 50014:1997+A1+A2:1999
- EN 50020:1994
- EN50284:1999
- II 1 G EEx ia IIC T4

PM880: BASEEFA02ATEX0191

Baseefa (2001) Ltd/EECS, Buxton SK17 9JN, UK

MMS 35IS: ISSeP01ATEX035 X; ISSeP, B7340 Colfontaine, Belgium

- EN 61326:1998, Class A, Annex C, Continuous Unmonitored Operation (for EN 61000-4-3, the **MMS 35IS** meets performance Criteria A and, in a limited number of frequencies, performance Criteria B per EN 61326.)

gemäß den Europäischen Richtlinien, Niederspannungsrichtlinie
EMV-Richtlinie Nr.: 89/336/EG und ATEX Richtlinie Nr. 94/9/EG.

Die oben aufgeführten Geräte und zugehörige, mitgelieferte Sensoren und Handhabungssysteme tragen keine CE-Kennzeichnung gemäß der Druckgeräte-Richtlinie, da sie in Übereinstimmung mit Artikel 3, Absatz 3 (gute Ingenieurpraxis) der Druckgeräte-Richtlinie 97/23/EG für DN<25 geliefert werden.

Shannon - July 1, 2003

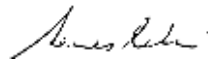

Mr. James Gibson
GENERALDIREKTOR



