

Electrarray® Hazardous Location Strobe Warning Light

Model 225XST and 225XST-I



DESIGNED FOR USE IN HAZARDOUS LOCATIONS

- 12-24VDC, 24VDC, 120VAC and 240VAC
- Six lens colors
- 5,000 hour, high-intensity strobe tube
- 1/2-inch NPT pipe mount
- Indoor/outdoor use
- Type 4X, IP66 enclosure (Dome up orientation)
- UL and cUL Listed and CSA Certified

Federal Signal's Electrarray® Model 225XST hazardous location strobe light provides 80 high intensity flashes per minute. This warning light is available in 12-24VDC, 24VDC, 120VAC and 240VAC.

The Model 225XST has been certified by UL as meeting Type 4X water tight and corrosion resistant requirements; constructed to IP66 (in dome up orientation). This hazardous location warning light has a black polyurethane coated base and the inner fresnel lens is available in six colors (including magenta). The clear polycarbonate outer dome can be quickly removed for easy access to inspect the unit or change the lamp. The 225XST has an effective candela of 240 and a 580,000 peak candela.

The 24VDC 225XST-I features a voltage in-rush limiting PCB design that provides greater compatibility with factory automation control systems and less electrical interference with in-rush sensitive devices.

The 225XST is UL Listed and CSA Certified for Class I, Division 2, Groups A, B, C and D; Class II, Division 2, Groups F and G; and Class III.

Model 225XST is ideal for wet, corrosive atmospheres like those found in food processing industries, or anywhere a visual signa is needed.

Federal Signal's affordable Electrarray Strobe Warning Light is specifically designed for use in hazardous locations or where corrosive materials are present.

Model	Voltage	Operating Current	Flash Rate/Minute	Candela Peak ¹	ECP ²	Mount
225XST-012-024 *	12-24VDC	1.70-0.70 amps	80	580,000	240	1/2" NPT Pipe
225XST-I-024 *	24VDC	0.70 amps (2.0 amp In-rush)	80	580,000	240	1/2" NPT Pipe
225XST-120 *	120VAC	0.25 amps	80	580,000	240	1/2" NPT Pipe
225XST-240 *	240VAC	0.20 amps	80	580,000	240	1/2" NPT Pipe

* Indicates color: (A) Amber, (B) Blue, (C) Clear, (G) Green (M) Magenta or (R) Red

Hazardous Location Rating:

T-Code at Maximum Ambient Temperature, °C

Hazardous Location	40°C
Class I, Div 2, Groups A, B, C, D	T3/200
Class II, Div 2, Groups F, G	T5/100
Class III	T5/100

¹ Peak candela is the maximum light intensity generated by a flashing light during its light pulse

² ECP (Effective Candela) is the intensity that would appear to an observer if the light were burning steadily



ELECTRARAY® HAZARDOUS LOCATION WARNING LIGHT (225XST/225XST-I)

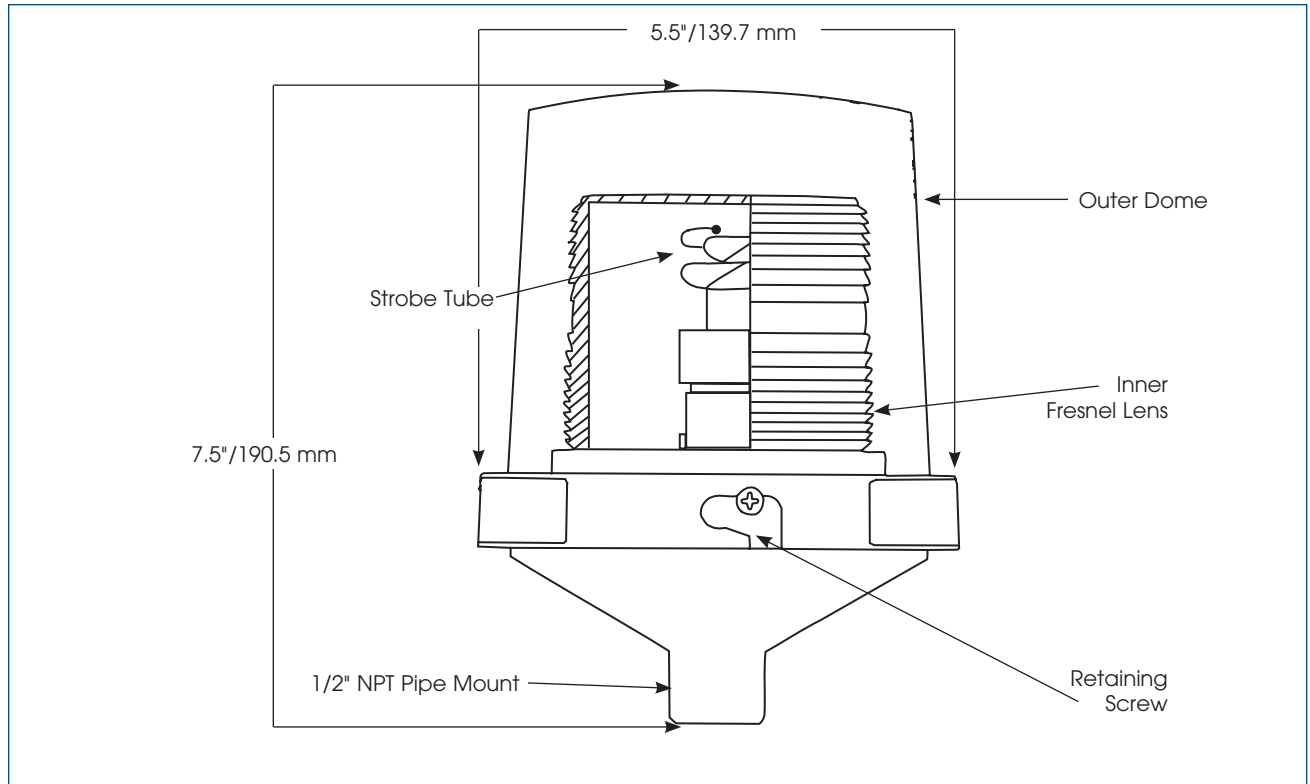

SPECIFICATIONS

Lamp Life:	10,000 Hours	10,000 Hours
Light Source:	Strobe tube	Strobe tube
Operating Temperature:	-40°F to 104°F	-40°C to 40°C
Net Weight:	1.5 lbs.	0.68 kg
Shipping Weight:	2.0 lbs.	0.9 kg
Height:	7.5"	190.5 mm
Diameter:	5.5"	139.7 mm

HOW TO ORDER

- Specify model, voltage and color
- Optional Accessories:
Hazardous Wall Bracket (LHWB)
- Please refer to Model Number Index
225XST/225XST-I beginning on
page 372

REPLACEMENT PARTS

<i>Description</i>	<i>Part Number</i>	<i>Description</i>	<i>Part Number</i>
Interior Lens		Exterior Dome, Clear	K8444D219C-04
Amber	K8550C095A-02	PC Assembly, 24VDC	K2001202C-01
Blue	K8550C095A-01	PC Assembly, 120VAC	K2001905A
Clear	K8550C095A	PC Assembly, 240VAC	K2001905A-01
Green	K8550C095A-04	Strobe Tube	K8107177A
Magenta	K8550C095A-07		
Red	K8550C095A-03		